

Victaulic® Couplings

Vibration Attenuation Characteristics



Style 77



Style W77



Style 177



Style 177N

BACKGROUND

In 2013, Victaulic successfully completed a test program at NASA's Vibration and Acoustic Test Facility (VATF). The test program was developed to determine the damping effect and vibration reduction capabilities of Victaulic flexible couplings and to compare the results to double sphere rubber connectors and stainless steel braided pump connectors.

The VATF at the NASA Johnson Space Center, is a versatile, dynamic structural test facility. The facility provides the capability to perform testing of both aerospace and non-aerospace hardware. Capabilities include testing of components as small as a few ounces to as large as complete structures or systems.



TEST SUMMARY

Vibration attenuation testing was performed on 4" – 12"/100 mm – 300 mm, 18"/450 mm, and 24"/600 mm Victaulic flexible couplings installed on standard wall carbon steel pipe. The test results

Job/Owner

System No.	
Location	

Contractor

Submitted By	
Date	

illustrated that three Victaulic flexible couplings placed in close proximity to mechanical equipment will attenuate vibration exceeds that of the tested double sphere rubber connectors and stainless steel braided pump connectors. The piping assemblies were pressurized up to 300 psi/20 bar and subjected to a frequency range of 10 Hz – 2000 Hz.

IMPORTANCE OF VIBRATION ATTENUATION IN PIPING SYSTEMS

Vibration and noise in connected piping can be generated by equipment (e.g., pumps, chillers, etc.). As stated on page 48.42 in the 2011 ASHRAE Handbook HVAC Applications SI Edition, "Any vibrating, reciprocating, or rotating equipment should be mounted such that it does not transmit significant levels of vibration into the surrounding or supporting structure. Vibrations transmitted via machine mounts or attached piping, ductwork, or electrical connections can result in vibrating walls, floors, and/or ceilings, which in turn radiate sound and/or vibration. Hence, it is important to provide vibration isolation for all attachments to a vibrating machine, including structural mounts and the connections to piping, ductwork, and the electrical system."

As stated on page 48.49 in the 2011 ASHRAE Handbook HVAC Applications SI Edition, "The piping system must be flexible enough to (1) reduce vibration transmission along the connected piping, (2) allow equipment movement without reducing the performance of vibration isolators, and (3) accommodate equipment movement or thermal movement of the piping at connections without imposing undue strain on the connections and equipment."

For pumps, every time the vane passes a given point, the fluid receives an impulse at that point. The repetition rate or vane passage frequency contributes to the vibration, and is typically associated with the pump speed and the number of vanes on the impeller. Doubling the number of vanes, or doubling the rate at which it rotates, doubles the vane passage frequency. For most pumps, speeds are usually 1200 to 3600 rpm, which can yield shaft rotation frequencies of 20 – 60 Hz, and vane passage frequencies of 100 – 360 Hz.

Engineer

Spec Section	
Paragraph	
Approved	
Date	

HOW VICTAULIC COUPLINGS ATTENUATE VIBRATION

Victaulic flexible couplings, such as the Styles 75, 77, 177, 177N and W77, for IPS pipe, and Style 31 couplings assembled with flexible radius cut grooved AWWA ductile iron pipe, permit controlled pipe movement within the couplings while maintaining a positive seal and a self-restrained joint. The design allows for expansion, contraction and deflection generated by thermal changes, building or ground settlement, and seismic activity.

Since Victaulic flexible couplings are not rigidly affixed to the pipe, unlike welded, flanged or threaded joints, the couplings minimize noise and vibration transmission generated by pumps or other equipment to the piping system. In addition, the elastomer gasket within each coupling and the pipe end gap attenuate system vibration. The use of additional Victaulic couplings throughout the piping system, whether flexible or rigid types, will further reduce the transmission of vibration.

Elastomeric flexible connectors and stainless steel braided pump connectors have traditionally been incorporated by engineers and contractors in piping systems by typically relying upon the traditional acceptance of these products for attenuating vibration.

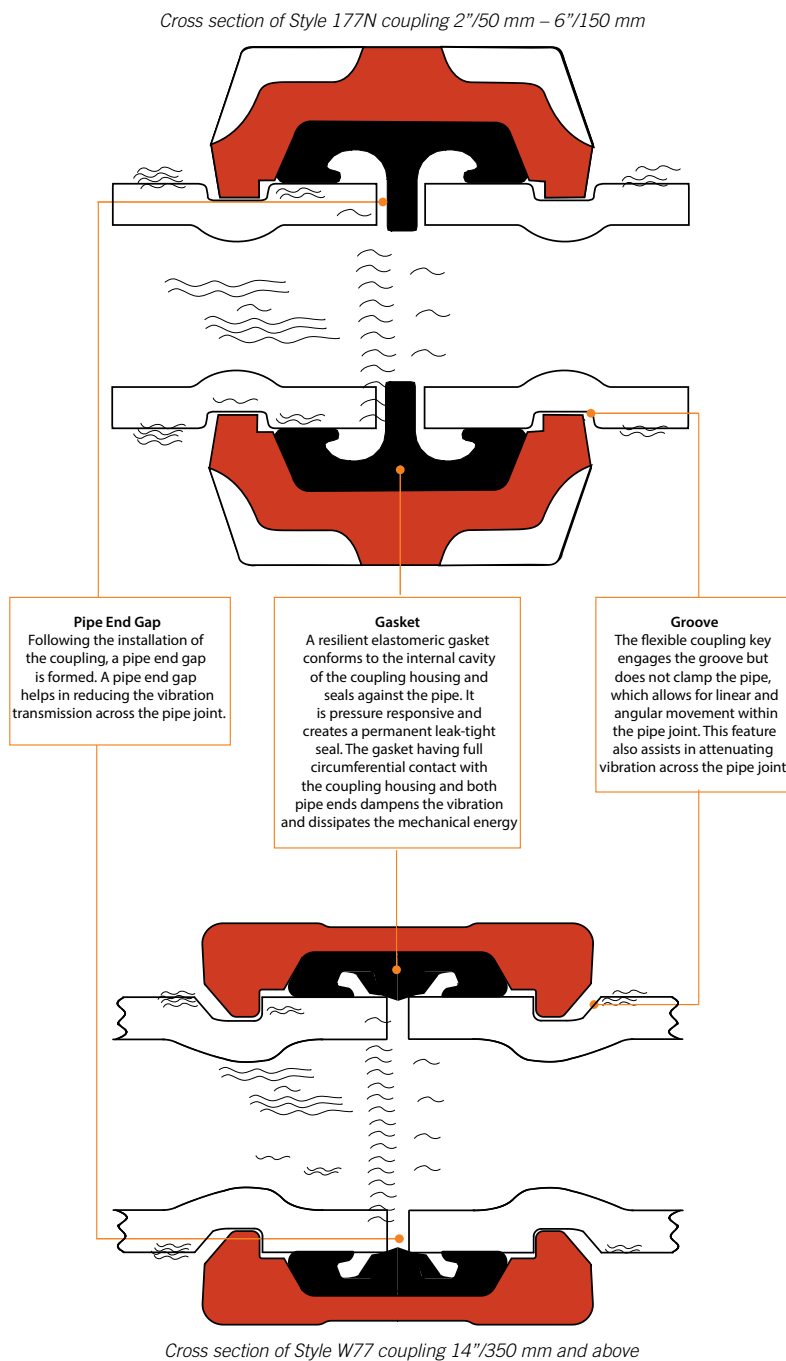

VIBRATION ATTENUATION TEST

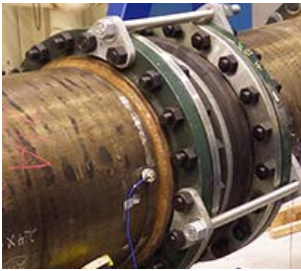
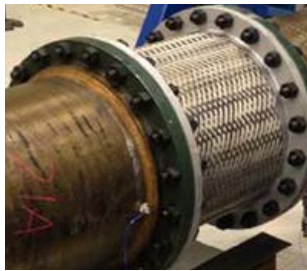
Products Tested		
Victaulic Flexible Couplings	Double Sphere Rubber Connector	Stainless Steel Braided Pump Connector
		

A series of test-article configurations were assembled using combinations of one, two, and three Victaulic flexible couplings, Styles 77, 177, 177N, and W77, for pipe diameters of 4" - 12"/100 mm - 300 mm, 18"/450 mm, and 24"/600 mm. Test configurations were also assembled for each of these pipe sizes using double sphere rubber connectors and stainless steel braided pump connectors.

All pipe assemblies were filled with water and pressurized up to 300 psi/20 bar, which exceeds typical operating pressures of HVAC systems. Tri-axial accelerometers were used to measure the level of vibration at the source and after the device being tested.

The vibration tests were performed at a numerically-controlled sinusoidal sweep over the frequency range from 10 Hz – 2000 Hz. A sinusoidal vibration simulates the mechanical and hydraulic induced vibrations of various pumps and rotating equipment over a given frequency. The magnitude of the sinusoidal sweep was an acceleration of 1 g (approximately 386 in/sec²). A sweep rate of one octave per minute was used for each test. This sweep rate allowed sufficient data to be collected to determine the vibration response of each test configuration.

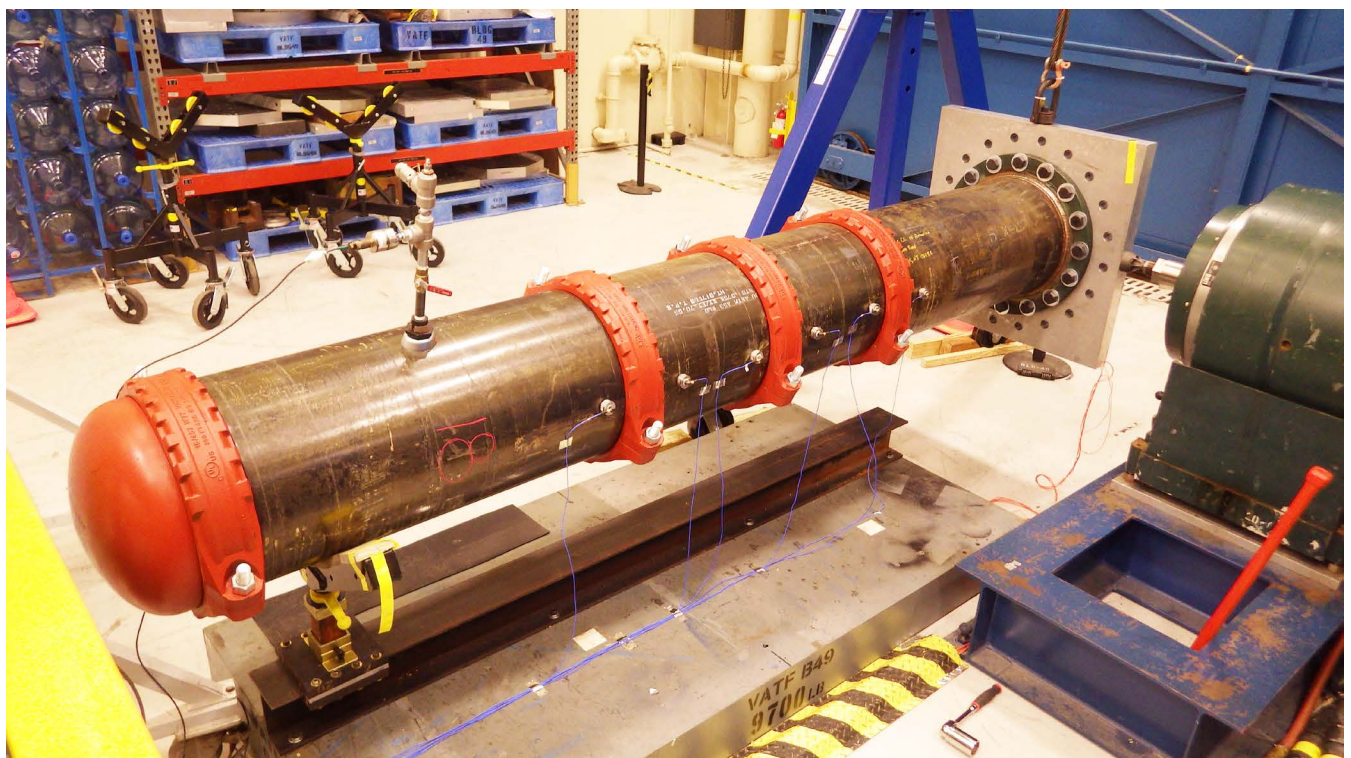

VIBRATION ATTENUATION TEST RESULTS

The results of the described tests performed apply only to Victaulic flexible couplings and cannot be applied to other coupling manufacturers. Victaulic couplings have a unique proprietary design and use gaskets constructed from synthetic engineered polymers, whose chemical formulation and processing techniques are unique and optimized for long life.

The following charts, show the relative vibration attenuation characteristics of three (3) Victaulic flexible couplings compared to double sphere rubber connectors and stainless steel braided pump connectors, respectively, for typical HVAC pump speeds. The test results show that in all sizes, the vibration attenuation provided by three (3) Victaulic flexible couplings installed in close proximity to the source of vibration, exceed the vibration attenuation characteristics of the other products tested. Additional flexible coupling features include linear movement and angular deflection capabilities and their ability to accommodate piping misalignment which will reduce stresses at pump or equipment connections. For any given pipe diameter; vibration isolation increases as the number of Victaulic flexible couplings increases (i.e. less vibration is transmitted with each additional coupling). The use of cut grooved or roll grooved pipe has the same vibration attenuation characteristics.

The vibration attenuation provided by three (3) Victaulic flexible couplings installed in close proximity to the source vibration is superior when compared to double sphere rubber connectors and stainless steel braided pump connectors. This vibration attenuation solution is cost effective and provides additional system benefits such as reducing loads at equipment connections and accommodating piping movement.

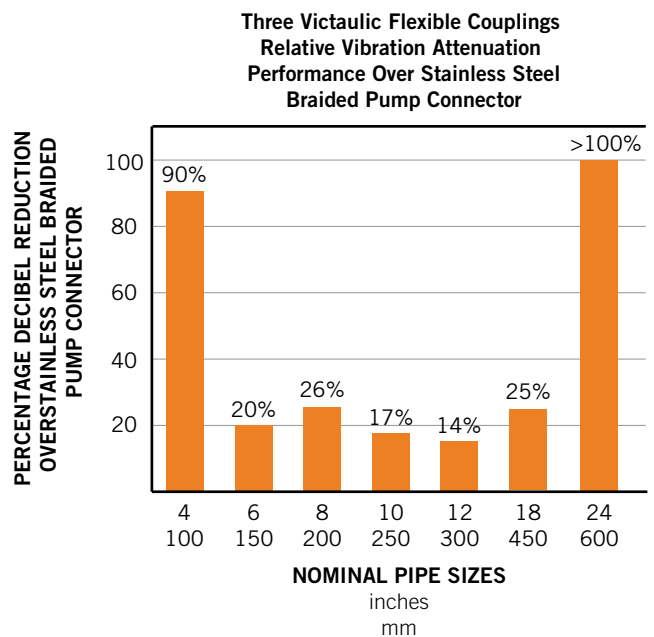
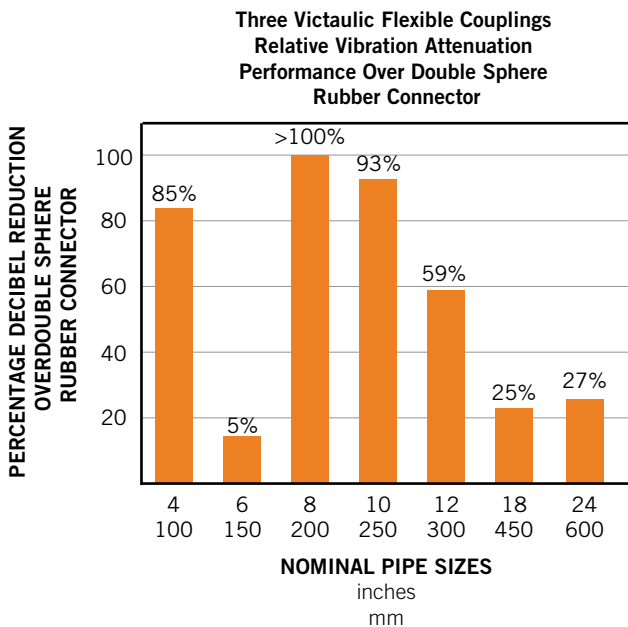

TYPICAL ASSEMBLIES UTILIZING THREE VICTAULIC FLEXIBLE COUPLINGS

The following are examples of typical assemblies utilizing the three (3) Victaulic flexible coupling arrangement. An indirect yet valuable advantage of our products is that the same couplings used for vibration attenuation are also used for system assembly.

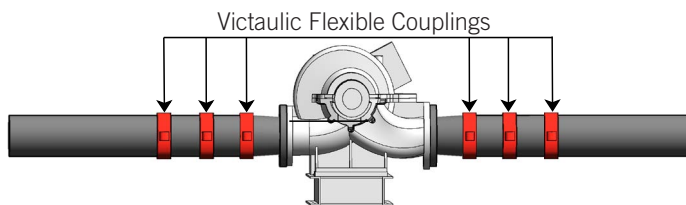
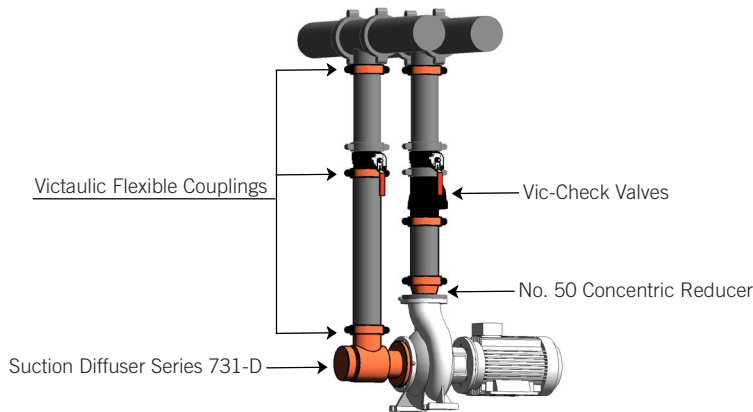
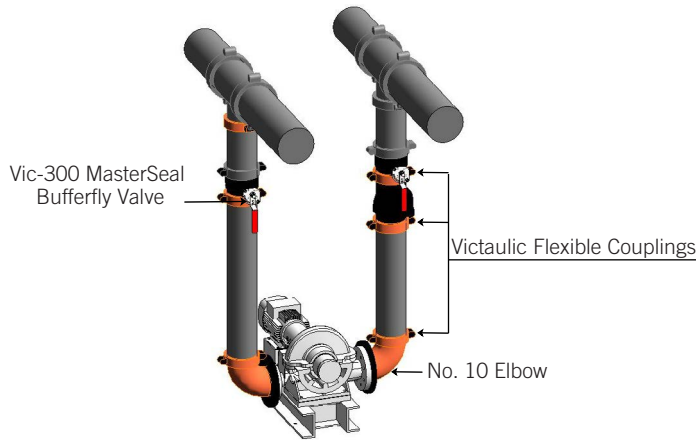

The piping models shown are for illustrative purposes only, and do not depict properly supported systems

Installation

Reference should always be made to the [I-100 Victaulic Field Installation Handbook](#) for the product you are installing. Handbooks are included with each shipment of Victaulic products for complete installation and assembly data, and are available in PDF format on our website at www.victaulic.com.

Warranty

Refer to the Warranty section of the current Price List or contact Victaulic for details.

Note

This product shall be manufactured by Victaulic or to Victaulic specifications. All products to be installed in accordance with current Victaulic installation/assembly instructions. Victaulic reserves the right to change product specifications, designs and standard equipment without notice and without incurring obligations.

Trademarks

Victaulic® is a registered trademark of Victaulic Company.