



Victaulic General Catalog



General Catalog

G-103
UPDATED 6/2009



G-103
UPDATED 6/2009



Piping. Systems. Solutions.



Worldwide leader
in mechanical pipe
joining solutions









Welcome to Victaulic.

The worldwide leader in mechanical pipe joining solutions. Since pioneering grooved end technology for mechanical pipe joining in 1925, Victaulic has been providing customers the world over with innovative, reliable piping systems solutions for multiple applications and markets.

Headquartered in the US with offices in Canada, Europe, the Middle East, United Kingdom, China and Belgium, Victaulic works closely with facility owners, engineers and contractors, in the installation of systems that compress schedules, reduce risk, improve productivity and facilitate system maintenance and expansion.

Technology Timeline

Since 1925, Victaulic has been at the forefront of mechanical piping systems innovation with over 1,500 patents for piping related products.

- 1925**  Victaulic introduces the first grooved end coupling, the "Victory Joint"
- 1930**  AWWA-size ductile iron system introduced
- 1946**  First field-grade cut groovers brought to market
- 1957**  Victaulic introduces roll grooving
- 1979**  First mechanical coupling for joining high density polyethylene (HDPE) pipe
- 1983**  First angled-bolt pad rigid coupling introduced
- 1991**  Victaulic introduces first small diameter IPS-size pipe press connect system
- 2005**  Advance Groove System large diameter pipe joining system introduced
- 2006**  Victaulic introduces installation-ready technology



Multiple markets served

Victaulic piping systems solutions span many markets. Our piping systems are found around the world in thousands of applications – from commercial comfort piping systems; industrial process and utility piping; residential and commercial fire protection systems; oil and offshore drilling platforms; coal and mineral mining operations; and water and wastewater plants and facilities.

Victaulic facilities worldwide

Our global presence as a company ensures that our worldwide customers are served with speed and efficiency. Victaulic engineering and sales support personnel are ready to assist you with the details of your project, regardless of the location.

Manufacturing facilities in the US, Poland, China, and Canada combined with a worldwide distribution and delivery system means Victaulic products are accessible from virtually any location around the world. Please consult the back of this catalog or our website for worldwide contact information.



Piping systems innovation

Our customers know us for bringing a steady stream of product innovations to the marketplace year after year – innovations that significantly improve piping system performance; improve user productivity; and meet the specific design criteria of very complex piping system design challenges.

Victaulic ingenuity is driven in part from listening to our customers, and our commitment to finding practical solutions to the world's most demanding engineering and system installation challenges.

table of contents

- ii Global Solutions
- iv Grooved End Technology
- vi Approvals and Industry Standards
- viii Design Data
- 18-1 Product Index
- 19-2 Support and Services

PRODUCTS

- 1-1 Couplings
- 2-1 Fittings
- 3-1 Valves
- 4-1 Accessories
- 5-1 Advanced Groove System
- 6-1 Hole Cut Piping System
- 7-1 Plain End Piping System
- 8-1 Grooved System for Stainless Steel Pipe
- 9-1 Pressfit System for Stainless Steel Pipe
- 10-1 Plain End Piping System for HDPE Pipe
- 11-1 Grooved Copper
- 12-1 PermaLynx System for Copper Tube
- 13-1 Grooved AWWA Ductile Iron Pipe
- 14-1 Victaulic Depend-O-Lok® System
- 15-1 Aquamine® Reusable PVC Products
- 16-1 Gaskets
- 17-1 Pipe Preparation Tools
- 19-1 Piping Software



Global Solutions

A world of applications at work

Our solutions are truly global.

Victaulic piping systems solutions are found in some of the world's most stunning and challenging engineering projects – buildings that arguably “push the design and construction envelope.”

Custom solutions for demanding challenges

Whether new construction or retrofit, Victaulic delivers a level of versatility unmatched in mechanical piping systems technology for today's engineering marvels.



Victaulic solutions provide superior design flexibility, the ability to accommodate seismic moments, noise and vibration attenuation, system access, system scalability, installation-friendly products and service, and more.

Projects spanning the globe

The projects illustrated here are just a few of the many buildings around the world for which Victaulic has provided innovative piping solutions.

For additional information on these and many other projects around the world, click on **Global Projects** from the home page of our website.

Victaulic



UNITED STATES
Hoover Dam



UNITED ARAB EMIRATES
Jumeirah Burj Al Arab and Beach Hotels



CHINA
Beijing National Stadium



CANADA
La Chateau Frontenac



FRANCE
La Grande Arche de la Défense



MALAYSIA
Petronas Twin Towers



UNITED STATES

CANADA

EUROPE

CENTRAL & SOUTH AMERICA

MIDDLE EAST

ASIA PACIFIC

Grooved End Technology

The worldwide standard in mechanical piping systems

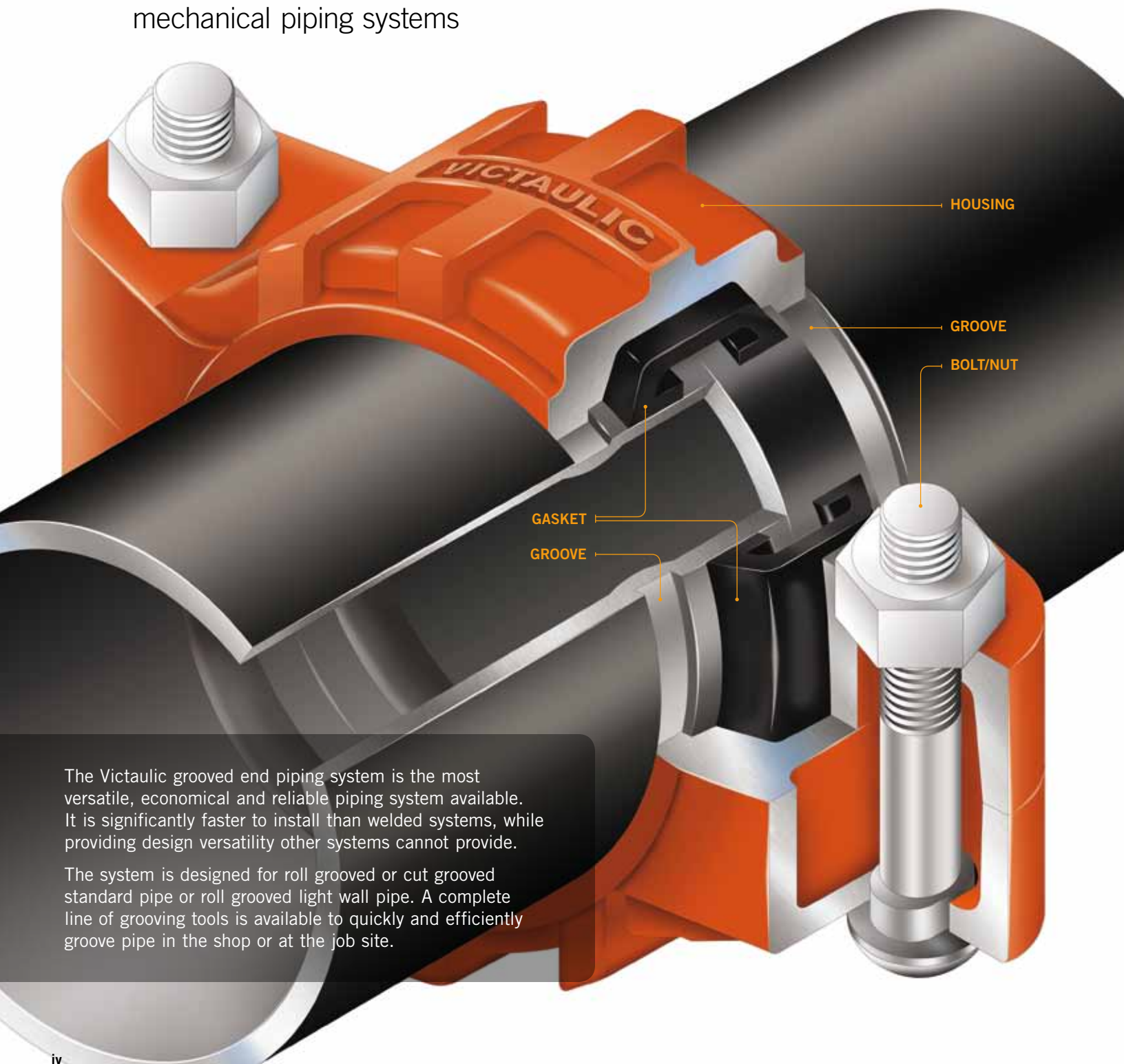

The Victaulic grooved end piping system is the most versatile, economical and reliable piping system available. It is significantly faster to install than welded systems, while providing design versatility other systems cannot provide.

The system is designed for roll grooved or cut grooved standard pipe or roll grooved light wall pipe. A complete line of grooving tools is available to quickly and efficiently groove pipe in the shop or at the job site.

Features

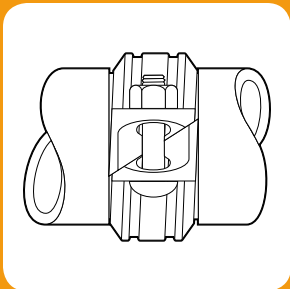

RIGIDITY

Rigidity is achieved with standard couplings. The unique angled pad design of Zero-Flex and other couplings provides positive clamping of the pipe to resist torsional and flexural loads.

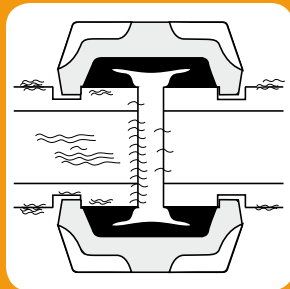

NOISE AND VIBRATION ATTENUATION

The basic design of independently grooved pipe sections reduces noise and vibration transmission, thus delivering superior vibration attenuation throughout the system.

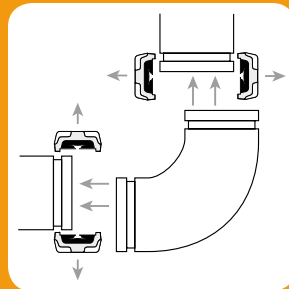

SYSTEM MAINTENANCE AND EXPANSION

Coupling disassembly provides easy access for maintenance or system expansion. Victaulic butterfly valves provide “dead-end” shut-off service to isolate equipment.

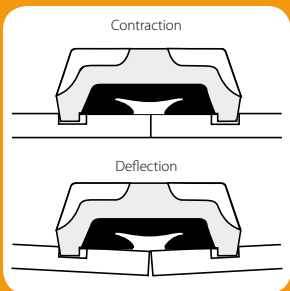

FLEXIBILITY

The Victaulic grooved end solution accommodates expansion/contraction/deflection and enables designing that takes advantage of these built-in system features.

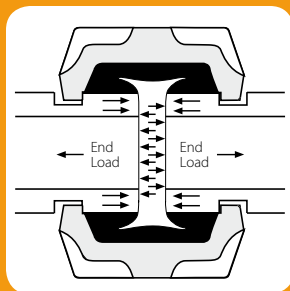

SEISMIC STRESS ABSORPTION

The full engagement of the housing keys into grooves around the pipe circumference provides significant pressure restraint and end load capability to withstand pipe movement from internal and external sources.

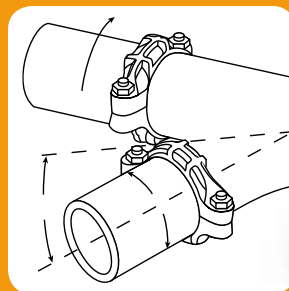

ALIGNMENT EASE

The grooved system allows full rotation of the pipe and system components before tightening so that proper alignment can be achieved.

Reinventing Innovation

The result of continuous research and development, today's Victaulic system has evolved since it was first introduced in 1925. But the basic concept hasn't changed.

Product innovation is a Victaulic hallmark. We are dedicated to finding faster, easier and more reliable ways to mechanically join pipe.



Accepted Worldwide

Victaulic grooved end, plain end, Pressfit® and other piping system components are tested and accepted for a variety of services throughout the world by the primary code and approval bodies.

A partial listing of the many agencies, associations, code group laboratories and organizations which have accepted, listed and tested Victaulic products are shown on the facing page. Copies of specific standards can be obtained by contacting your local Victaulic representative, or by requesting publication 02.02.



**GENERAL CODE GROUPS,
ASSOCIATIONS, LABORATORIES
AND APPROVAL BODIES**



ABS
American Bureau of Shipping



ANSI
American National
Standards Institute

ANSI/AWWA
American Water Works
Association – C-606

API
American Petroleum Institute –
API Std. 5L, Sect. 7.5

AS
AS4041-1992 Australian Standard
(3.24.10)

ASHRAE
American Society of Heating,
Refrigerating and Air Conditioning
Engineers

ASME
American Society of
Mechanical Engineers

- Power Piping, B-31.1
- Chemical Plant and Petroleum
Refinery Piping, B-31.3
- Refrigeration Piping, B-31.5
- Building Services Piping, B-31.9
- Slurry Pipelines, B-31.11

ASTM
American Society
of Testing and Materials

- F-1476 Couplings
- F-1548 Fittings
- F-1155 Shipbuilding



BBA
British Board of Agrément



BOCA
Building Officials and
Code Administrators



BV
Bureau Veritas

CCCF
China Certification Center
for Fire Products



CE
Certification to the European
Directive for Pressure Equipment

CNBOP
Centrum Naukowo-Badawcze
Ochrony Przeciwpozarowej

CNPP APSAD
Centre National de Prévention
et de Protection



CSA
Canadian Standards Association –
B-242, registered to CAN 3-Z299.3



cULus
Underwriter's Laboratories, Inc. -
Listed for the fire protection services

DIN GÖST TÜV
Zertifizierungssystem für Produkte



DNV
Det Norske Veritas



DVGW
Deutscher Verein des
Gas- und Wasserfaches e.V.

EMI
Epitesugyi Minosegellenorzo
Innovacious



FM
FM Approvals –
Approved for fire protection services

GL
Germanischer Lloyd

GOST R

HDB
Singapore Housing
Development Board

Hong Kong Fire Services Board



IAPMO
International Association of Plumbing
& Mechanical Officials

Korean Registry of Shipping

Krajska Hygienicka

INSTAL

- AT/2000
- AT/2002
- AT/2003



LLOYD'S
Lloyd's Register of Shipping



LPCB
Loss Prevention Certification Board

New Zealand Insurance Council

New Zealand Building Act (1991)

NFPA
National Fire Protection Association

ClassNK
NK
Nippon Kaiji Kyokai



NSF/ANSI 61
Standard 61 for potable
water service

NY-MEA
New York Materials and
Equipment Acceptance

ÖVGW
Österreichische Vereinigung für
das Gas- und Wasserfach

PED
CE 97/23

PZH
Panstwowy Zaklad Higieny

RINA
Registro Italiano Navale



SBCCI
Southern Building Code Congress
International – Standard Plumbing
and Mechanical Code

SBSC
Svensk Brand & Säkerhets
Certifiering AB

SRIPS
Service de Recherche et
d'Ingénierie en Protection Sanitaire

SSL
Scientific Services Laboratory

Standards Australia

SVGW
Schweizerischer Verein des
Gas- und Wasserfaches

TSU
Technický Skúšobný Ústav
Piešťany, š.p.



UL
Underwriter's Laboratories, Inc. –
Listed for fire protection services



ULC Underwriter's Laboratories
of Canada – Listed for fire
protection services



VdS
Verband der
Schadenverhütung GmBH

VKF
Vereinigung Kantonaler
Feuerversicherungen



W
Standards Australia Watermark
Certification

WRAS
Water Regulations
Advisory Scheme

GOVERNMENT AGENCIES

Bureau of Marine Inspection –
Salt and fresh water, oil transfer

Bureau of Public Roads –
Div. of Bridges – Drain lines
and bridge crossings

Canadian Coast Guard

U.S. Coast Guard – Approves
each vessel individually

COE
Corps of Engineers –
CEGS 15000

FAA
Federal Aviation Administration –
HVAC, Plumbing, Fire Protection
Federal Code of Regulations –

- A-A-52598 – Couplings
- A-A-52592 – Fittings

FHA
Federal Housing Administration

GSA
General Services
Administration – 15000 Series

MIL
Military Specifications

- MILP-10388 Fittings
- MIL-C-10387 Couplings
- MIL-P-11087A(CE)
Steel Pipe, Grooved
- MIL-I-45208 Inspection Procedure

NASA
National Aeronautics and Space
Administration – 15000 Series

NAVFAC
Naval Facilities Engineering
Command – NFGS 15000 Series

NIH
National Institute of Health
(Dept. of Health) – 15000 Series

TVA
Tennessee Valley Authority –
Fire protection, storm drains

VA
Veterans Affairs – 15000 Series

Design Data

Introduction

This Victaulic General Catalog has been written for the piping system installer, designer, specification writer and owner as a basic reference guide for data about Victaulic mechanical piping methods. This catalog is organized to provide information in the context and form most readily usable. For easy identification of major sections of interest, see the condensed table of contents on pg. i, for a fully detailed index, see pg. 18-1. For more detailed information, consult Design Data, Section 26.01.

Important Information

Victaulic has developed, in over 80 years in mechanical piping, variations of piping practice for use on a wide variety of piping materials.

Victaulic standard grooved pipe couplings are designed for use with pipe grooved to meet Victaulic groove specifications and Victaulic grooved end fittings, valves, and related grooved end components only. They are not intended for use with plain end pipe and/or fittings. Victaulic plain end couplings are designed for use only with plain end or beveled end steel pipe (unless otherwise indicated) and Victaulic plain end fittings.

Victaulic plain end couplings must not be used with grooved end or threaded end pipe and/or fittings. Nor are they intended for use with Advanced Groove System (AGS) components used on 14–24"/350–600 mm pipe sizes.

Pipe must be prepared to meet Victaulic specifications outlined for each specific product style. Performance data listed herein is based on proper pipe preparation. The proper gasket must be selected for the service intended. **It should be noted that there are various services for which Victaulic gaskets are not recommended. Reference should always be made to the latest Victaulic Gasket Selection Guide (request publication 05.01) for specific gasket service recommendations and for a listing of services which are not recommended. Gaskets for Victaulic products always must be lubricated for proper assembly.** Gasket lubricant must meet manufacturer's specifications. Thorough lubrication of the gasket exterior, including the lips and/or pipe ends and housing interiors, is essential to prevent gasket pinching. Lubrication assists proper gasket seating and alignment during installation.

Victaulic has a complete line of tools for preparing pipe to Victaulic specifications. Use of these tools is recommended in preparing pipe to receive Victaulic products. Always read and understand the Tool Operating Instructions supplied with every Victaulic tool prior to using any tools. All data contained herein, is subject to change without notice.

Design Data

Notice

The technical and performance data, weights, dimensions and specifications published in this catalog supersede all previously published data.

Victaulic Company maintains a policy of continual product improvement and, therefore, reserves the right to change product specifications, designs, and standard equipment without notice and without incurring obligation.

For the most up-to-date Victaulic product information, please visit www.victaulic.com.

The material presented in this catalog is intended for piping design reference in utilization of Victaulic products for their intended application. It is not intended as a substitute for competent, professional assistance which is an obvious requisite to any specific application.

Design

Reference should always be made to design information available at no charge on request from Victaulic. Good piping practices should always prevail. Specific pressures, temperatures, external or internal loads, performance standards and tolerances must never be exceeded. Many applications require recognition of special conditions, code requirements and use of safety factors. Qualified engineers must make these decisions.

While every effort has been made to ensure its accuracy, Victaulic Company, its subsidiaries and affiliated companies, make no express or implied warranty of any kind respecting the information contained in this catalog or the material referred to herein.

Anyone making use of the information or material contained herein does so at their own risk and assumes any and all liability resulting from such use.

Installation

Reference should always be made to the specific Victaulic Field Installation Handbook for the product you are installing. The following is a list of handbooks that can be requested for free from Victaulic:

I-100	General Handbook
I-300	AWWA Products Handbook
I-500	Pressfit System Handbook
I-600	Copper Products Handbook
I-900	HDPE Products Handbook

Handbooks are included with each shipment of Victaulic products for complete installation and assembly data, and are available in PDF format on our website at www.victaulic.com.

All rights reserved. No part of this Victaulic catalog may be reproduced, stored in a retrieval system, or transmitted, in any form or by any means, electronic, mechanical, photocopy, recording or otherwise, without the prior written permission of Victaulic Company.

© Copyright 2009, Victaulic Company.

® Registered trademark of Victaulic Company.

Design Data

Global Pipe Size Designations

Victaulic product data is utilized worldwide and all technical data is shown in both imperial (U.S.) and metric terms. The following chart shows a comparison between typical metric and IPS pipe sizes.

Nominal Imperial Inches – Size Group	Outside Diameter mm/Spec Ref	DIN mm	JIS mm	ANSI inches	China Standard (GB) mm
1/2	21.3 mm	15	15 A/21.7 mm	1/2	15*/21.3 mm
3/4	26.7 mm	20/26.9 mm	20 A/27.2 mm	3/4	20*/26.9 mm
1	33.4 mm	25/33.7 mm	25 A/34 mm	1	25*/33.7 mm
1 1/4	42.2 mm	32/42.4 mm	32 A/42.7 mm	1 1/4	32*/42.4 mm
1 1/2	48.3 mm	40	40 A/48.6 mm	1 1/2	40*/48.3 mm
2	60.3 mm	DN & ISO 50	50 A/60.5 mm	2	50*/60.3 mm
2 1/2	73.1 mm	—	—	2 1/2	—
3	76.1 mm DIN/ISO (3 OD)	DN & ISO 65	65 A/76.3 mm	—	65*/76.1 mm
	88.9 mm	DN & ISO 80	JIS 80 A	3	80*/88.9 mm
4	108 mm China and old DIN	DIN 108 mm	—	—	108 mm
	114.3 mm	DN & ISO 100	JIS 100 A	4	100*/114.3 mm
5	133 mm China and old DIN	DIN 133 mm	—	—	133 mm
	139.7 mm DIN/ISO (5.5 OD)	DN & ISO 125	125 A/139.8 mm	—	125*/139.7 mm
	141.3 mm	—	—	5	—
6	159 mm China and old DIN	DIN 159 mm	—	—	159 mm
	165.1 mm JIS (6.5 OD)	—	150 A/165.2 mm	—	—
	168.3 mm	DN & ISO 150	—	6	150*/168.3 mm
8	216.3 JIS	—	JIS 200 A	—	—
	219.1 mm	DN 200	—	8	219.1 mm
10	267.4 JIS	—	JIS 250 A	—	—
	273 mm	DN 250	—	10	273 mm
12	318.5 JIS	—	JIS 300 A	—	—
	323.9 mm	DN 300	—	12	323.9 mm
14	355.6 mm	DN 350	JIS 350 A	14	355.6 mm
	377 mm China	—	—	—	377 mm
16	406.4 mm	DN 400	JIS 400 A	16	406.4 mm
	426 mm China	—	—	—	426 mm
18	457.2 mm	DN 450	JIS 450 A	18	457.2 mm
	480 mm China	—	—	—	480 mm
20	508 mm	DN 500	JIS 500 A	20	508 mm
	530 mm China	—	—	—	530 mm
22	558.8 mm	—	JIS 550 A	22	559 mm
24	610 mm	DN 600	JIS 600 A	24	610 mm
	630 mm China	—	—	—	630 mm
26	660 mm	—	JIS 650 A	26	660 mm
28	711 mm	DN 700	—	28	711 mm
30	762 mm	—	—	30	762 mm
32	813 mm	DN 800	—	32	813 mm
34	864 mm	—	—	34	864 mm
36	914 mm	DN 900	—	36	914 mm
40	1016 mm	DN 1000	—	40	1016 mm
42	1067 mm	DN 1050	—	42	1067 mm
44	1118 mm	DN 1100	—	44	1118 mm
46	1168 mm	DN 1150	—	46	1168 mm
48	1219 mm	DN 1200	—	48	1219 mm

IMPORTANT NOTE:

Nominal designations are used where the actual OD of the pipe matches the ANSI size. Otherwise both the nominal and actual OD are listed. China sizes are listed as actual OD in mm. China sizes in orange are tubing sizes.

* Nominal sizes

Design Data

Imperial (U.S.)/Metric Conversion Chart

This chart is provided as a guide for converting imperial and metric measurements provided within this catalog.

Convert Imperial (U.S.) to Metric				Convert Metric to Imperial (U.S.)		
25.4	×	Inches (In.)	↔	Millimeters (mm)	×	0.03937
0.3048	×	Feet (Ft.)	↔	Meters (m)	×	3.281
0.4536	×	Pounds (Lbs.)	↔	Kilograms (kg)	×	2.205
28.35	×	Ounces (Oz.)	↔	Grams (g)	×	0.03527
6.894	×	Pressure (psi)	↔	Kilopascals (kPa)	×	0.145
.069	×	Pressure	↔	Bar	×	14.5
4.45	×	End Load (Lbs.)	↔	Newtons (N)	×	0.2248
1.356	×	Torque (Lb. Ft.)	↔	Newton Meters (N·m)	×	0.738
F - 32 ÷ 1.8		Temp. (°F)	↔	Celsius (°C)	C + 17.78 × 1.8	
745.7	×	Horsepower (hp)	↔	Watts (w)	×	1.341 × 10 ⁻³
3.785	×	Gal. per Min. (GPM)	↔	Liters per min. (L/M)	×	0.2642
3.7865	×	10 ⁻³ Gal. per Min. (GPM)	↔	Cubic Meters per min. (m3/m)	×	264.2

Couplings

- Victaulic, the originator and innovator of grooved coupling technology, offers a variety of coupling sizes and styles for almost any piping application.
- Consisting of three basic components — the housing, the gasket, and bolts and nuts — Victaulic couplings provide a simple, economical method for joining carbon steel, copper, stainless steel, ductile iron, aluminum, HDPE and PVC plastic piping systems.
- Victaulic couplings provide designers with versatility not found in other pipe joining methods. Victaulic rigid and flexible couplings can be combined to allow for thermal growth within the system. Additionally, the use of three consecutive flexible couplings reduces noise and vibration and eliminates costly specialty noise dampeners.

QuickVic®
Rigid Coupling
STYLE 107, PG. 1-5



QuickVic®
Flexible Coupling
STYLE 177, PG. 1-7



Advanced Groove System **AGS™**



For 14–24"/350–600 mm piping systems Victaulic offers Advanced Groove System (AGS) couplings, see pg. 5-1.

Zero-Flex®
Rigid Coupling
STYLE 07, PG. 1-6
AGS STYLE W07, PG. 5-3



Standard Flexible
Coupling
STYLE 77, PG. 1-8
AGS STYLE W77, PG. 5-3



Flexible
Coupling
STYLE 75, PG. 1-9



Large Diameter
Pipe Coupling
STYLE 770, PG. 1-10



Vic-Flange® Adapter
ANSI Class 150/PN10
STYLE 741, PG. 1-11
AGS STYLE W741, PG. 5-5

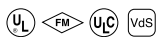

Vic-Flange Adapter
ANSI Class 300/PN16
STYLE 743, PG. 1-12



Reducing
Coupling
STYLE 750, PG. 1-13







Snap-Joint®
Coupling
STYLE 78, PG. 1-14



Couplings

Gasket Types

Gasket Type	Style 107	Style 117	Style 07	Style 77	Style 75	Style 770	Style 750	Style 78	Style 72 †	Style 791	Style HP-70	Style HP-70ES
STANDARD 			●	●	●	●		●	●	●	●	
INSTALLATION-READY 	●	●										
REDUCING 							●					
FLUSHSEAL 			●	●	●	●		●		●		
ENDSEAL 												●

† Separate gasket specifically designed for outlet couplings.

Outlet Coupling

STYLE 72, PG. 1-15



Available with female threaded outlets (shown) and grooved outlets

Vic-Bottless® Coupling

STYLE 791 AND STYLE 792 ASSEMBLY TOOL, PG. 1-16



Rigid Coupling

STYLE HP-70, PG. 1-17

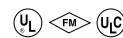

High Pressure Coupling

STYLE 808, PG. 1-18



Endseal® Coupling for Plastic Coated Pipe

STYLE HP-70ES, PG. 1-19



EndSeal Fittings for Plastic Coated Pipe

PG. 1-20



EndSeal products are specifically designed to meet the stringent requirements of oil field piping systems. The special groove profile and gasket design of “ES” products contribute to higher pressure ratings and longer life service.

PRODUCTS

1-1 Couplings

- 2-1 Fittings
- 3-1 Valves
- 4-1 Accessories
- 5-1 Advanced Groove System
- 6-1 Hole Cut Piping System
- 7-1 Plain End Piping System
- 8-1 Grooved System for Stainless Steel Pipe
- 9-1 Pressfit System for Stainless Steel Pipe
- 10-1 Plain End Piping System for HDPE Pipe
- 11-1 Grooved Copper
- 12-1 PermaLynx System for Copper Tube
- 13-1 Grooved AWWA Ductile Iron Pipe
- 14-1 Victaulic Depend-O-Lok® System
- 15-1 Aquamine Reusable PVC Products
- 16-1 Gaskets
- 17-1 Pipe Preparation Tools
- 18-1 Product Index
- 19-1 Piping Software

Couplings

Rigid Coupling Systems and Performance §

Rigid couplings have a unique, patented angled pad design which constricts the housing keys into the groove around the full circumference to create a rigid joint. The housings slide on the angled pads rather than mating squarely.

This sliding movement also forces the key sections into opposed contact on the inside and the outside groove edges, which locks the coupling onto the pipe ends and creates a rigid connection.

These rigid couplings provide a rigid joint allowing no expansion/contraction or linear movement. The couplings will position the pipe ends so that there is a fixed pipe end separation that may be considered during design and installation (see chart below).

Rigid couplings create a rigid joint, useful for risers, mechanical rooms and other areas where flexibility is not desired. QuickVic Style 107, Zero-Flex Style 07 and Style W07 AGS couplings are designed to provide rigidity to permit hanging to ASME B31.1 Power Piping Code, ASME B31.9 Building Services Piping Code and NFPA 13 Sprinkler Systems.

Size		Allow. Pipe End Sep.
Nominal Size Inches mm	Actual Outside Diameter Inches mm	Inches mm
¾	1.050	0.05
	26.9	1.2
1	1.315	0.05
	33.7	1.2
1¼	1.660	0.05
	42.4	1.2
1½	1.900	0.05
	48.3	1.2
2	2.375	0.07
	60.3	1.7
2½	2.875	0.07
	73.0	1.7
76.1 mm	3.000	0.07
	76.1	1.7
3	3.500	0.07
	88.9	1.7
108.0 mm	4.250	0.16
	108.0	4.1
4	4.500	0.16
	114.3	4.1
133.0 mm	5.250	0.16
	133.0	4.1
139.7 mm	5.500	0.16
	139.7	4.1

Size		Allow. Pipe End Sep.
Nominal Size Inches mm	Actual Outside Diameter Inches mm	Inches mm
5	5.563	0.16
	141.3	4.1
159.0 mm	6.250	0.16
	159.0	4.1
165.1 mm	6.500	0.16
	165.1	4.1
6	6.625	0.16
	168.3	4.1
8	8.625	0.19
	219.1	4.8
10	10.750	0.13
	273.0	3.3
12	12.750	0.13
	323.9	3.3
14*	14.000	0.13
	355.6	3.3
16*	16.000	0.13
	406.4	3.3
18*	18.000	0.13
	457.0	3.3
20*	20.000	0.13
	559.0	3.3
24*	24.000	0.13
	610.0	3.3

§ Except for HP-70 and HP-70ES coupling which have the following allowable pipe end separation:

HP-70:

2–4"/50–100 mm sizes: 0.14"/3.6 mm

6–12"/150–300 mm sizes: 0.25"/6.4 mm

HP-70ES:

2–4"/50–100 mm sizes: 0.19"/4.8 mm

6–8"/150–200 mm sizes: 0.27"/6.7 mm

10–12"/250–300 mm sizes: 0.28"/7.1 mm

* These figures do NOT apply to 14–24"/350–600 mm Style W07 AGS rigid couplings. Allowable pipe end separation is 0.25"/6.9 mm for all sizes of Style W07.

IMPORTANT NOTES:

ONLY FLEXIBLE couplings are recommended for the installation of expansion loops as stated in Calculating and Accommodating Pipe Line Thermal Growth Section 26.02. All eight couplings assembling the four elbows of the loop must be flexible. The use of rigid couplings to install the straight run adjacent to the expansion loop is a recommended practice.

This also applies to couplings installed on the perpendicular leg(s) at the end(s) of a straight pipe run or on pipe line offsets. If system movement is to be accommodated, flexible couplings must be utilized.

Rigid couplings must NOT be utilized to accommodate any system movement.

Should you have any questions regarding the proper use of our products, contact Engineering Services at engserv@victaulic.com.

WARNING

Depressurize and drain the piping system before attempting to install, remove, or adjust any Victaulic piping products. Failure to do so could result in personal injury, property damage, joint leakage and/or joint failure.

Couplings

Flexible Coupling Systems and Performance §

Standard flexible grooved-type couplings allow controlled angular, linear and rotational movement at each joint to accommodate expansion/contraction (see note below), settling, vibration, noise and other piping system movement. These features provide advantages in designing piping systems but must be considered when determining hanger and support spacing and location.

Victaulic couplings offer superior vibration attenuation characteristics to both flexible metal and elastomeric flexible arch-type connectors.

Independent vibration testing data (request publication 26.04) verifies that three Victaulic couplings in close proximity to a vibration source (pump, equipment, etc.) provide superior vibration attenuation in piping systems.

Both flexible and rigid couplings offer reduced construction schedules, plus the convenience of a union at every joint and the proven pressure-responsive “C” shaped Victaulic gasket. Both type products fit into standard roll or cut grooved pipe and provide the security of full circumferential engagement of the coupling housing into the groove for high pressure and end load service.

Size		Allow. Pipe End Sep. †	Deflect. Fr. C _L †	
Nominal Size Inches mm	Actual Outside Diameter Inches mm		Inches mm	Degrees per Coupling
¾ 20	1.050 26.9	0 – 0.06 0 – 1.6	3° 24'	0.72 60
1 25	1.315 33.7	0 – 0.06 0 – 1.6	2° 43'	0.57 48
1¼ 32	1.660 42.4	0 – 0.06 0 – 1.6	2° 10'	0.45 38
1½ 40	1.900 48.3	0 – 0.06 0 – 1.6	1° 56'	0.40 33
2 50	2.375 60.3	0 – 0.06 0 – 1.6	1° 31'	0.32 27
2½ 65	2.875 73.0	0 – 0.06 0 – 1.6	1° 15'	0.26 22
76.1 mm	3.000 76.1	0 – 0.06 0 – 1.6	1° 12'	0.26 22
3 80	3.500 88.9	0 – 0.06 0 – 1.6	1° 2'	0.22 18
3½ 90	4.000 101.6	0 – 0.06 0 – 1.6	0° 54'	0.19 16
108.0 mm	4.250 108.0	0 – 0.13 0 – 3.2	1° 41'	0.35 29
4 100	4.500 114.3	0 – 0.13 0 – 3.2	1° 36'	0.34 28
4½ 120	5.000 127.0	0 – 0.13 0 – 3.2	1° 26'	0.25 21
133.0 mm	5.250 133.0	0 – 0.13 0 – 3.2	1° 21'	0.28 23
139.7 mm	5.500 139.7	0 – 0.13 0 – 3.2	1° 18'	0.28 23
5 125	5.563 141.3	0 – 0.13 0 – 3.2	1° 18'	0.27 22
152.4 mm	6.000 152.4	0 – 0.13 0 – 3.2	1° 12'	0.21 17

Size		Allow. Pipe End Sep. †	Deflect. Fr. C _L †	
Nominal Size Inches mm	Actual Outside Diameter Inches mm		Inches mm	Degrees per Coupling
159.0 mm	6.250 159.0	0 – 0.13 0 – 3.2	1° 9'	0.24 20
165.1 mm	6.500 165.1	0 – 0.13 0 – 3.2	1° 6'	0.23 19
6 150	6.625 168.3	0 – 0.13 0 – 3.2	1° 5'	0.23 19
203.2 mm	8.000 203.2	0 – 0.13 0 – 3.2	0° 54'	0.16 13
8 200	8.625 219.1	0 – 0.13 0 – 3.2	0° 50'	0.18 15
254.0 mm	10.000 254.0	0 – 0.13 0 – 3.2	0° 43'	0.15 13
10 250	10.750 273.0	0 – 0.13 0 – 3.2	0° 40'	0.14 12
304.8 mm	12.000 304.8	0 – 0.13 0 – 3.2	0° 36'	0.13 11
12 300	12.750 323.9	0 – 0.13 0 – 3.2	0° 34'	0.12 10
14 @ 350	14.000 355.6	0 – 0.13 0 – 3.2	0° 31'	0.11 9
15 375	15.000 381.0	0 – 0.13 0 – 3.2	0° 29'	0.10 8
16 @ 400	16.000 406.4	0 – 0.13 0 – 3.2	0° 27'	0.10 8
18 @ 450	18.000 457.0	0 – 0.13 0 – 3.2	0° 24'	0.08 7
20 @ 500	20.000 508.0	0 – 0.13 0 – 3.2	0° 22'	0.08 7
22 550	22.000 559.0	0 – 0.13 0 – 3.2	0° 19'	0.07 6
24 @ 600	24.000 610.0	0 – 0.13 0 – 3.2	0° 18'	0.07 6

§ Except for Style 72 outlet couplings. Contact Victaulic for details.

† NOTE: These values are based on standard roll grooved pipe. Figures for standard cut grooved pipe may be doubled. See notes below.

@ Allowable pipe end separation for Style W77 AGS flexible couplings in this size range are 0.125 – 0.375/3.1 – 9.5 mm.

*** GENERAL NOTES:**

Working Pressure and End Load are total, from all internal and external loads, based on standard weight (ANSI) steel pipe, standard **roll** or **cut** grooved in accordance with Victaulic specifications. Contact Victaulic for performance on other pipe.

Warning: For one time field test only, the Maximum Joint Working Pressure may be increased to 1½ times the figures shown (except Style HP-70ES).

Allowable Pipe End Separation and Deflection figures show the maximum nominal range of movement available at each joint for standard **roll** grooved pipe. Figures for standard **cut** grooved pipe may be doubled. These figures are maximums; for design and installation purposes these figures should be reduced by: 50% for ¾ – 3½/20 – 90 mm; 25% for 4/100 mm and larger.

Important Notes:

Metric thread size bolts are available (color coded gold) for all coupling sizes upon request. Contact Victaulic for details.

Couplings

QuickVic® Rigid Coupling

STYLE 107

For Complete Information
Request Publication 06.19



COUPLINGS

- Installation ready design
- Angled-pad design for rigidity
- Pressure rated up to 580 psi/4000kPa
- Sizes from 2 – 8" / 50 – 200mm

Size		Allow. Pipe End Sep. †	@ Bolt/Nut	Dimensions Inches/mm					Approx. Wgt. Each
Nominal Size Inches/mm	Actual Outside Dia. Inches/mm			Inches/mm	No. – Size Inches/mm	Preassembled (Installation-ready condition)		Joint Assembled	
		X	Y			X	Y	Z	Lbs/Kg
2 50	2.375 60.3	0.12 3.1	2 – 1½ x 3 M12 x 3	4.08	6.15	3.66	5.98	1.93	2.7
				104	156	93	152	49	1.2
2½ 65	2.875 73.0	0.12 3.1	2 – 1½ x 3 M12 x 3	4.61	6.77	4.16	6.54	1.94	3.1
				117	172	106	166	49	1.4
76.1 mm	3.000 76.1	0.12 3.1	2 – M12 x 3	4.74	6.99	4.38	6.82	1.94	3.3
				120	178	111	173	49	1.5
3 80	3.500 88.9	0.12 3.1	2 – 1½ x 3 M12 x 3	5.18	7.42	4.82	7.13	1.94	3.5
				132	188	122	181	49	1.6
4 100	4.500 114.3	0.21 5.3	2 – 1½ x 3 M12 x 3	6.43	8.84	6.03	8.43	2.13	5.1
				163	225	153	214	54	2.3
139.7 mm	5.500 139.7	0.26 6.60	2 – M16 x 3¼	7.58	10.52	7.33	10.40	2.13	6.0
				190	264	172	260	54	2.7
5 125	5.563 141.3	0.21 5.3	2 – ⅝ x 3¼ M16 x 3¼	7.48	10.50	7.06	10.91	2.13	6.8
				190	267	180	277	54	3.1
6 150	6.625 168.3	0.21 5.3	2 – ⅝ x 3¼	8.65	11.54	8.21	11.12	2.13	8.2
				220	293	209	282	54	3.7
165.1 mm	6.500 165.1	0.2 5.08	2 – M16 x 3¼	8.7	11.65	8.46	11.57	2.13	7.9
				221	296	215	294	54	3.6
8 200	8.625 219.1	0.21 5.30	2 – ⅝ x 4 M16 x 4	10.55	13.74	10.17	13.62	2.67	9.1
				268	349	258	346	68	4.1

† The allowable pipe separation dimension shown is for system layout purposes only. Style 107 QuickVic rigid couplings are considered rigid connections and will not accommodate expansion or contraction of the piping system.

@ Number of bolts required equals number of housing segments.

WARNING: Depressurize and drain piping system before attempting to install, remove or adjust any Victaulic piping products.

ANSI STANDARD

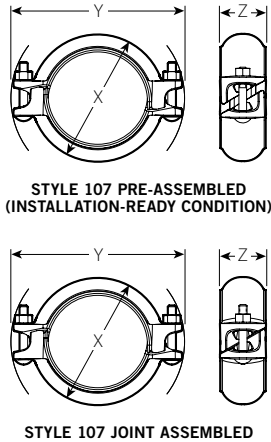

Size		Schedule 10			Schedule 40		
Nominal Inches/mm	Actual Outside Dia. Inches/mm	Wall Thick. Inches/mm	Max. * Joint Work. Press. psi/kPa	Max. * Permis. End Load Lbs./N	Wall Thick. Inches/mm	Max. * Joint Work. Press. psi/kPa	Max. * Permis. End Load Lbs./N
2 50	2.375 60.3	0.109	500	2215	0.154	580	2570
		2.77	3450	9857	3.91	4000	11437
2½ 65	2.875 73.0	0.120	400	2600	0.203	580	3765
		3.05	2750	11570	5.15	4000	16754
3 80	3.500 88.9	0.120	400	3850	0.216	580	5580
		3.05	2750	17133	5.49	4000	24831
4 100	4.500 114.3	0.120	400	6360	0.237	580	9220
		3.05	2750	28302	6.02	4000	41029
5 125	5.563 141.3	0.134	300	7290	0.258	580	14100
		3.40	2070	32428	6.55	4000	62720
6 150	6.625 168.3	0.134	360	12410	0.280	580	19990
		3.40	2480	55225	7.11	4000	88956
8 200	8.625 219.1	0.148	250	14607	0.322	580	33887
		3.76	1725	64975	8.18	4000	150737

* Working Pressure and End Load are total from all internal and external loads grooved in steel pipe in accordance with Victaulic specifications. Contact Victaulic for performance on other pipe. Refer to notes on pg. 1-4.

WARNING: FOR ONE TIME FIELD TEST ONLY, the Maximum Joint Working Pressure may be increased to 1 ½ times the figures shown.

Couplings

Zero-Flex Rigid Coupling

STYLE 07

For Complete Information
Request Publication **06.02**



- Angled-pad design for rigidity
- Resists flexural and torsional loads
- Pressure rated up to 750psi/5170kPa
- Sizes from 1 – 12”/25 – 300mm

Size		Max. Work Pressure *	Max. End Load *	Allow. Pipe End Sep. *	Dimensions			Approx. Wgt. Each
Nominal Size Inches mm	Actual Outside Dia. Inches mm	psi kPa	Lbs. N	Inches mm	X Inches mm	Y Inches mm	Z Inches mm	Lbs. kg
1	1.315	750	650	0.05	2.36	4.22	1.84	1.6
25	33.7	5175	2890	1.2	60	107	47	0.7
1¼	1.660	750	1,620	0.05	2.69	4.62	1.84	1.6
32	42.4	5175	7210	1.2	68	117	47	0.7
1½	1.900	750	2,130	0.05	2.94	5.81	1.84	1.6
40	48.3	5175	9480	1.2	75	148	47	0.7
2	2.375	750	3,320	0.07	3.35	5.78	1.84	2.3
50	60.3	5175	14775	1.7	85	147	47	1.0
2½	2.875	750	4,875	0.07	3.88	6.38	1.84	2.6
65	73.0	5175	21695	1.7	98	162	47	1.2
76.1 mm	3.000	750	5,300	0.07	4.21	6.61	1.84	3.6
	76.1	5175	23585	1.7	107	168	47	1.6
3	3.500	750	7,215	0.07	4.54	6.81	1.84	3.0
80	88.9	5175	32105	1.7	115	173	47	1.4
4	4.500	750	11,925	0.16	5.81	8.21	2.07	5.3
100	114.3	5175	53065	4.1	148	209	53	2.4
108.0 mm	4.250	750	10,635	0.16	5.56	7.98	2.07	5.2
	108.0	5175	47325	4.1	141	203	53	2.4
5	5.563	750	18,225	0.16	7.03	9.89	2.07	7.4
125	141.3	5175	81100	4.1	179	251	53	3.4
133.0 mm	5.250	700	15,145	0.16	6.69	9.60	2.07	7.4
	133.0	4825	67395	4.1	170	244	53	3.4
139.7 mm	5.500	700	16,625	0.16	6.94	9.82	2.07	7.6
	139.7	4825	73980	4.1	176	249	53	3.4
6	6.625	700	24,130	0.16	8.26	10.83	2.07	8.3
150	168.3	4825	107380	4.1	210	275	53	3.8
159.0 mm	6.250	700	21,465	0.16	7.84	10.54	2.07	9.2
	159.0	4825	95520	4.1	199	268	53	4.2
165.1 mm	6.500	700	23,225	0.16	8.13	10.84	2.07	8.3
	165.1	4825	103305	4.1	207	275	53	3.8
8 S	8.625	600	35,000	0.19	10.54	13.74	2.51	15.1
200	219.1	4130	155750	4.8	268	349	64	6.8
10 S	10.750	500	45,400	0.13	12.86	16.98	2.56	23.5
250	273.0	3450	202030	3.3	327	431	65	10.7
12 S	12.750	400	51,000	0.13	14.86	18.88	2.56	28.2
300	323.9	2750	226950	3.3	377	480	65	12.8
14 – 24 350 – 600	AGS™ For 14 – 24”/350 – 600 mm sizes Victaulic offers the Advanced Groove System (AGS) line of products, pg. 5-3. Request publication 20.02 for information on the rigid W07 AGS coupling.							

§ Couplings 8”/200mm, 10”/250mm, 12”/300mm sizes are available to JIS standards. Refer to Publication 06.17 for details.

* Refer to General Notes on pg. 1-4.

IMPORTANT NOTES:

Metric thread size bolts are available (color coded gold) for all coupling sizes upon request. Contact Victaulic for details.

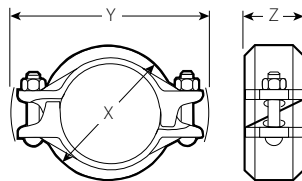

TYPICAL FOR ALL SIZES

Couplings

QuickVic Flexible Coupling

STYLE 177

For Complete Information
Request Publication 06.20

COUPLINGS



- Installation-ready design with no loose components
- Pressure rated up to 1000 psi/6900kPa
- Sizes from 2-6"/50-150mm

Size		Pipe End Sep. Inches mm			Bolt/Nut No. - Size	Dimensions - Inches/mm					Aprx. Wgt. Ea. Lbs. kg
Nominal Size Inches mm	Actual Outside Diameter Inches mm	(1) Min	(2) Max	(3) Max		Pre-assembled (Installation-ready condition)		Joint Assembled			
					X	Y	X	Y	Z		
2	2.375	0.13	0.19	0.25	2 - 3/8 x 2 1/2	3.87	5.59	3.56	5.39	2.05	2.0
50	60.3	3.2	4.8	6.4		98	142	90	1.37	52	0.9
2 1/2	2.875	0.13	0.19	0.25	2 - 3/8 x 2 1/2	4.36	6.13	4.05	5.89	2.05	2.4
65	73.0	3.2	4.8	6.4		111	156	103	150	52	1.1
3	3.500	0.13	0.19	0.25	2 - 1/2 x 3	5.00	7.05	4.68	6.81	2.04	3.1
80	88.9	3.2	4.8	6.4		127	179	119	173	52	1.4
4	4.500	0.13	0.25	0.38	2 - 1/2 x 3	5.98	8.24	5.61	7.92	2.15	3.7
100	114.3	3.2	6.4	9.5		152	209	142	201	54	1.7
6	6.625	0.13	0.25	0.38	2 - 5/8 x 3 1/4	8.23	11.18	7.95	10.92	2.09	6.3
150	168.3	3.2	6.4	9.5		209	284	202	277	53	2.9

(1) The minimum pipe end separation as required by the gasket center leg for roll or cut grooved pipe. See illustrations below.

(2 & 3) Maximum pipe end separation to be used for determining overall piping system movement for roll (2) or cut (3) groove pipe. For design and installation purposes, the minimum and maximum pipe end separations should be reduced to the values shown in the table below. These design and installation considerations include thermal growth, settlement, installation misalignment and offsets. See illustrations below.

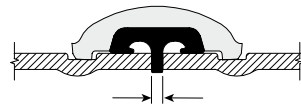

Minimum Pipe Separation (1)
Roll and Cut Groove

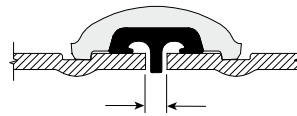

Maximum Pipe Separation (2)
Roll Groove

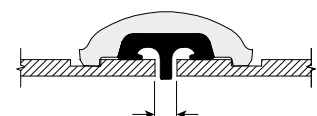

Maximum Pipe Separation (3) Cut Groove

Exaggerated for clarity

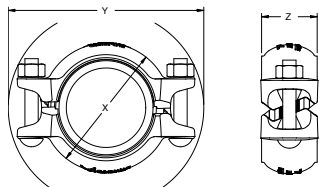

STYLE 177 PRE-ASSEMBLED
(INSTALLATION-READY CONDITION)

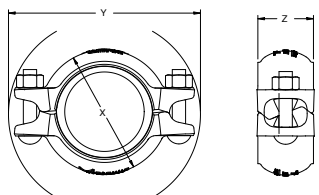

STYLE 177 JOINT ASSEMBLED

Size		Schedule 10 (Steel Pipe)			Schedule 40 (Steel Pipe)		
Nominal Inches Actual mm	Actual Outside Diameter Inches mm	Wall Thick. Inches mm	Max. * Joint Work. Press. psi/kPa	Max. * Perm. End Load Lbs./N	Wall Thick. Inches mm	Max. * Joint Work. Press. psi/kPa	Max. * Perm. End Load Lbs./N
			2	2.375		0.109	580
50	60.3	2.77	4000	11432	3.91	6900	19714
2 1/2	2.875	0.120	580	3765	0.230	1000	6492
60	73.0	3.05	4000	16754	5.84	6900	28889
3	3.500	0.120	580	5580	0.216	1000	9621
75	88.9	3.05	4000	24831	5.49	6900	42813
4	4.500	0.120	363	5773	0.237	580	9225
100	114.3	3.05	2500	25690	6.02	4000	41051
6	6.625	0.134	285	9824	0.28	580	19994
150	168.3	3.40	1965	43717	7.11	4000	88973

WARNING: Depressurize and drain the piping system before attempting to install, remove or adjust any Victaulic piping products.

* Working Pressure and End Load are total, from all internal and external loads, based on (ANSI) steel pipe, grooved in accordance with Victaulic specifications. Contact Victaulic for performance on other pipe.

WARNING: FOR ONE TIME FIELD TEST ONLY, the Maximum Joint Working Pressure may be increased to 1 1/2 times the figures shown.

Couplings

Standard Flexible Coupling

STYLE 77

For Complete Information
Request Publication **06.04**



- Cross-ribbed construction design
- Provides flexibility for expansion, contraction, and deflection
- Pressure rated up to 1000 psi/6900 kPa
- Sizes from 3/4 - 12"/20-600mm for roll or cut grooved systems. Sizes from 14-24"/350-600mm for cut grooved systems only.
- For 14-24"/350-600 mm AGS roll groove systems, see pg. 5-1

Size		Max. Work Pressure *	Max. End Load *	Allow. Pipe End Sep. *	Dimensions			Approx. Wgt. Each
Nominal Size Inches mm	Actual Outside Dia. Inches mm	psi kPa	Lbs. N	Inches mm	X Inches mm	Y Inches mm	Z Inches mm	Lbs. kg
3/4	1.050	1000	865	0 - 0.06	2.13	4.00	1.75	1.1
20	26.7	6900	3850	0 - 1.6	54	102	44	0.5
1	1.315	1000	1,360	0 - 0.06	2.38	4.12	1.75	1.2
25	33.4	6900	6050	0 - 1.6	61	105	44	0.5
1 1/4	1.660	1000	2,160	0 - 0.06	2.65	5.00	1.88	2.0
32	42.2	6900	9610	0 - 1.6	67	127	48	0.9
1 1/2	1.900	1000	2,835	0 - 0.06	3.13	5.38	1.88	2.1
40	48.3	6900	12615	0 - 1.6	79	137	48	1.0
2	2.375	1000	4,430	0 - 0.06	3.63	5.88	1.88	2.6
50	60.3	6900	19715	0 - 1.6	92	149	48	1.2
2 1/2	2.875	1000	6,490	0 - 0.06	4.25	6.50	1.88	3.1
65	73.0	6900	28880	0 - 1.6	108	165	48	1.4
76.1 mm	3.000	1000	7,070	0 - 0.06	4.38	6.63	1.88	3.2
	76.1	6900	31460	0 - 1.6	111	168	48	1.5
3	3.500	1000	9,620	0 - 0.06	5.00	7.13	1.88	3.7
80	88.9	6900	46810	0 - 1.6	127	181	48	1.7
3 1/2	4.000	1000	12,565	0 - 0.06	5.63	8.25	1.88	5.6
90	101.6	6900	55915	0 - 1.6	143	210	48	2.5
4	4.500	1000	15,900	0 - 0.13	6.13	8.88	2.13	6.7
100	114.3	6900	70755	0 - 3.2	156	226	54	3.0
108.0 mm	4.250	1000	14,180	0 - 0.13	6.00	8.63	2.13	11.0
	108.0	6900	63100	0 - 3.2	152	219	54	5.0
5	5.563	1000	24,300	0 - 0.13	7.75	10.65	2.13	10.6
125	141.3	6900	108135	0 - 3.2	197	270	54	4.8
133.0 mm	5.250	1000	21,635	0 - 0.13	7.63	10.38	2.13	10.0
	133.0	6900	96275	0 - 3.2	194	264	54	4.5
139.7 mm	5.500	1000	23,745	0 - 0.13	8.63	10.65	2.13	10.0
	139.7	6900	105665	0 - 3.2	219	270	54	4.5
6	6.625	1000	34,470	0 - 0.13	8.63	11.88	2.13	12.0
150	168.3	6900	153390	0 - 3.2	219	302	54	5.4
159.0 mm	6.250	1000	30,665	0 - 0.13	8.63	11.50	2.13	13.2
	159.0	6900	136460	0 - 3.2	219	292	54	6.0
165.1 mm	6.500	1000	33,185	0 - 0.13	8.88	11.63	2.13	13.2
	165.1	6900	147660	0 - 3.2	226	295	54	6.0
8 S	8.625	800	46,740	0 - 0.13	11.00	14.75	2.50	20.8
200	219.1	5500	207995	0 - 3.2	279	375	63	9.4
10 S	10.750	800	73,280	0 - 0.13	13.63	17.13	2.63	31.1
250	273.0	5500	326100	0 - 3.2	346	435	67	14.1
12 S	12.750	800	102,000	0 - 0.13	15.63	19.25	2.63	27.8
300	323.9	5500	453900	0 - 3.2	397	489	67	12.6
14#	14.000	300	46,180	0 - 0.13	16.63	19.88	2.88	35.6
350	355.6	2065	205500	0 - 3.2	422	505	73	16.1
16#	16.000	300	60,320	0 - 0.13	19.00	22.13	3.00	51.1
400	406.4	2065	268425	0 - 3.2	482	562	76	23.2
18#	18.000	300	76,340	0 - 0.13	21.38	24.50	3.13	64.4
450	457.2	2065	339710	0 - 3.2	543	622	80	29.2
20#	20.000	300	94,000	0 - 0.13	23.63	27.25	3.13	91.2
500	508.0	2065	418300	0 - 3.2	600	692	80	41.4
22#	22.000	300	114,000	0 - 0.13	25.75	29.50	3.13	92.0
550	559.0	2065	507300	0 - 3.2	654	749	80	41.7
24#	24.000	250	113,000	0 - 0.13	27.75	31.25	3.13	94.0
600	609.6	1725	502850	0 - 3.2	704	794	80	42.6
14 - 24 350 - 600	AGS™ For 14 - 24"/350 - 600 mm sizes Victaulic offers the Advanced Groove System (AGS) line of products, pg. 5-3. Request publication 20.03 for information on the flexible W77 AGS coupling.							

§ Couplings 8"/200mm, 10"/250mm, 12"/300mm sizes are available to JIS standards. Refer to Publication 06.17 for details.

For use on cut groove systems only. For roll grooved systems Victaulic offers the Advanced Groove System (AGS), see pg. 5-1. For cut groove fittings in this size contact our Engineered Products Group at 610-559-3300.

* Refer to General Notes on pg. 1-4.

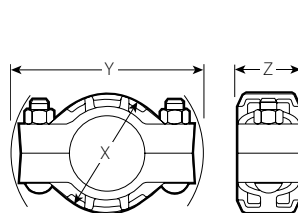

TYPICAL 3/4-12"/20-300 mm SIZES

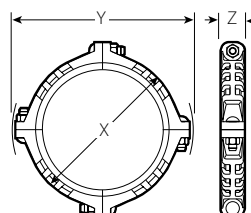

TYPICAL 14-22"/350-550 mm SIZES

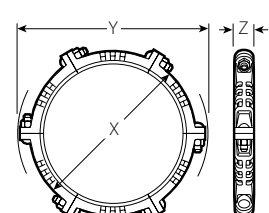

TYPICAL 24"/600 mm SIZES

Couplings

Flexible Coupling

STYLE 75

For Complete Information
Request Publication **06.05**

COUPLINGS



- For use where moderate pressures are expected and weight considerations are a factor
- 50% lighter in weight than Style 77
- Housings cast in two identical pieces in all sizes
- Pressure rated up to 500 psi/3450kPa
- Sizes from 1 – 12"/25 – 304.8mm

Size		Max. Work Pressure *	Max. End Load *	Allow. Pipe End Sep. *	Dimensions			Approx. Wgt. Each
Nominal Size Inches mm	Actual Outside Dia. Inches mm	psi kPa	Lbs. N	Inches mm	X Inches mm	Y Inches mm	Z Inches mm	Lbs. kg
1	1.315	500	680	0 – 0.06	2.38	4.27	1.77	1.3
25	33.4	3450	3025	0 – 1.6	61	108	45	0.6
1¼	1.660	500	1,080	0 – 0.06	2.68	4.61	1.77	1.4
32	42.2	3450	4805	0 – 1.6	68	117	45	0.6
1½	1.900	500	1,420	0 – 0.06	2.91	4.82	1.77	1.5
40	48.3	3450	6320	0 – 1.6	74	122	45	0.6
2	2.375	500	2,215	0 – 0.06	3.43	5.22	1.88	1.7
50	60.3	3450	9860	0 – 1.6	87	133	48	0.8
2½	2.875	500	3,245	0 – 0.06	3.88	5.68	1.88	1.9
65	73.0	3450	14440	0 – 1.6	98	144	48	0.9
76.1 mm	3.000	500	3,535	0 – 0.06	4.00	5.90	1.88	1.9
	76.1	3450	15730	0 – 1.6	102	150	48	0.9
3	3.500	500	4,800	0 – 0.06	4.50	7.00	1.88	2.9
80	88.9	3450	21360	0 – 1.6	114	178	48	1.3
3½	4.000	500	6,300	0 – 0.06	5.00	7.50	1.88	2.9
90	101.6	3450	28035	0 – 1.6	127	191	48	1.3
4	4.500	500	7,950	0 – 0.13	5.80	8.03	2.13	4.1
100	114.3	3450	35380	0 – 3.2	147	204	54	1.9
108.0 mm	4.250	450	6,380	0 – 0.13	5.55	7.79	2.13	3.7
	108.0	3100	28395	0 – 3.2	141	198	54	1.7
4½	5.000	450	8,820	0 – 0.13	6.13	9.43	2.13	5.5
120	127.0	3100	39250	0 – 3.2	156	240	54	2.5
5	5.563	450	10,935	0 – 0.13	6.88	10.07	2.13	5.8
125	141.3	3100	48660	0 – 3.2	175	256	54	2.6
133.0 mm	5.250	450	9,735	0 – 0.13	6.55	9.37	2.13	6.0
	133.0	3100	43325	0 – 3.2	166	238	54	2.7
139.7 mm	5.500	450	10,665	0 – 0.13	6.80	9.59	2.13	6.3
	139.7	3100	47460	0 – 3.2	173	244	54	2.9
6	6.625	450	15,525	0 – 0.13	8.00	11.07	2.13	7.0
150	168.3	3100	69085	0 – 3.2	203	281	54	3.2
159.0 mm	6.250	450	13,800	0 – 0.13	7.63	10.49	2.13	6.8
	159.0	3100	61405	0 – 3.2	194	266	54	3.1
165.1 mm	6.500	450	14,940	0 – 0.13	7.84	10.66	2.06	7.2
	165.1	3100	66483	0 – 3.2	199	271	52	3.3
8	8.625	450	26,280	0 – 0.13	10.34	13.97	2.32	12.4
200	219.1	3100	116945	0 – 3.2	263	355	59	5.6
203.2 mm#	8.000	450	22,635	0 – 0.13	9.72	13.33	2.31	12.6
	203.2	3100	100725	0 – 3.2	247	339	58	5.7
254.0 mm#	10.000	350	27,500	0 – 0.13	12.16	15.81	2.53	20.8
	254.0	2400	122375	0 – 3.2	309	402	64	9.4
304.8 mm#	12.000	350	39,500	0 – 0.13	14.16	17.69	2.53	23.6
	304.8	2400	175775	0 – 3.2	360	449	64	10.7

Style 74 Couplings.

* Refer to General Notes on pg. 1-4.

IMPORTANT NOTES:

Metric thread size bolts are available (color coded gold) for all coupling sizes upon request. Contact Victaulic for details.

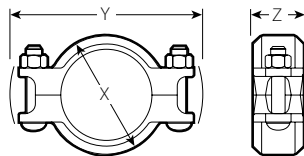

TYPICAL FOR ALL SIZES

Couplings

Large Diameter Pipe Coupling

STYLE 770

For Complete Information
Request Publication **06.03**



- Ideal for carbon steel, galvanized or stainless steel pipe
- Pressure rated up to 375psi/2580kPa
- Sizes from 26–42"/650–1050mm

Size		Max. Work Pressure *	Max. End Load *	Coupling Dimensions			Nominal Range of Linear Movement ‡		Approx. Wgt. Each
Nominal Size Inches mm	Actual Outside Dia. Inches mm	psi kPa	Lbs. N	X Inches mm	Y Inches mm	Z Inches mm	Minimum Inches mm	Maximum Inches mm	Lbs. kg
26 650	26.000 660.4	375 2580	199,099 885990	29.75 756	34.25 870	5.00 127	0 0	0.38 9.7	150.0 68.0
28 700	28.000 711.0	330 2270	203,199 904236	31.75 807	36.33 923	5.00 127	0 0	0.38 9.7	175.0 78.0
30 750	30.000 762.0	300 2065	212,058 943658	33.75 857	38.32 973	5.00 127	0 0	0.38 9.7	200.0 90.7
32 800	32.000 813.0	260 1790	209,105 930517	35.75 908	40.43 1027	5.00 127	0 0	0.38 9.7	225.0 102.1
36 900	36.000 914.0	200 1380	203,575 905909	39.75 1010	44.33 1126	5.00 127	0 0	0.38 9.7	250.0 113.4
42 1050	42.000 1067.0	145 1000	200,890 893961	45.75 1162	51.56 1310	5.76 146	0.31 7.9	0.69 17.5	400.0 181.4

* Refer to General Notes on pg. 1-4.

‡ Nominal linear movement and deflection are dependent upon pipe properly roll or cut grooved to Victaulic specifications. Maximum allowable linear movement is the difference between minimum and maximum pipe end separation subject to tolerances (Request Publication 26.01).

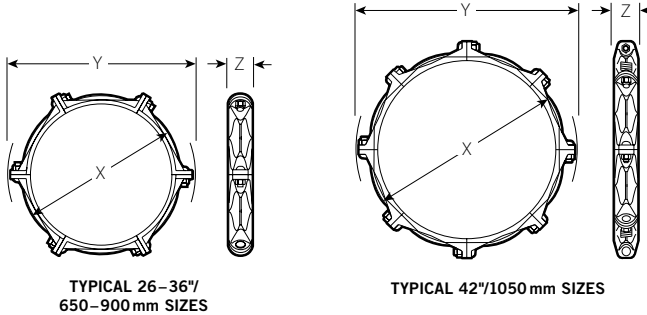

Couplings

Vic-Flange Adapter ANSI Class 150/PN10

STYLE 741

For Complete Information
Request Publication 06.06

COUPLINGS

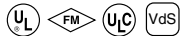

- Directly incorporates ANSI Class 125 or Class 150 flanged components into a grooved system
- Pressure rated up to 300psi/2065kPa
- Sizes from 2–12"/50–300mm are hinged
- Sizes 14–24"/350–600mm are cast in four identical segments

Size		Max. Work Pressure *	Max. End Load *	Sealing Surface		Dimensions		Approx. Wgt. Each
Nominal Size Inches mm	Actual Outside Dia. Inches mm			A Max. Inches mm	B Min. Inches mm	W Inches mm	Z Inches mm	
2	2.375	300	1,330	2.38	3.41	6.75	0.75	3.1
50	60.3	2065	5920	60	87	172	19	1.4
2½	2.875	300	1,950	2.88	3.91	7.87	0.88	4.8
65	73.0	2065	8680	73	99	200	22	2.1
3	3.500	300	2,885	3.50	4.53	8.29	0.94	5.3
80	88.9	2065	12840	89	115	211	24	2.4
4	4.500	300	4,770	4.50	5.53	9.87	0.94	7.4
100	114.3	2065	21225	114	141	251	24	3.4
5	5.563	300	7,290	5.56	6.71	10.90	1.00	8.6
125	141.3	2065	32440	141	171	277	25	3.9
6	6.625	300	10,350	6.63	7.78	11.90	1.00	9.9
150	168.3	2065	46060	168	198	302	25	4.5
165.1 mm	6.500	300	9,960	6.50	7.66	11.92	1.00	10.0
	165.1	2065	44320	165	195	303	25	4.5
8	8.625	300	17,500	8.63	9.94	14.50	1.13	16.6
200	219.1	2065	77875	219	252	368	29	7.5
10	10.750	300	27,215	10.75	12.31	17.24	1.19	24.2
250	273.0	2065	121110	273	313	438	30	11.0
12	12.750	300	38,285	12.75	14.31	20.25	1.25	46.8
300	323.9	2065	170270	324	364	514	32	21.2
14#	14.000	300	46,180	14.00	16.39	24.50	1.44	62.0
350	355.6	2065	205500	356	416	622	37	28.1
16#	16.000	300	60,300	16.00	18.39	27.12	1.44	79.0
400	406.4	2065	268335	406	467	689	37	35.8
18#	18.000	300	76,340	18.00	20.00	29.00	1.56	82.3
450	457.0	2065	339700	457	508	737	40	37.3
20#	20.000	300	94,250	20.00	22.50	31.50	1.69	103.3
500	508.0	2065	419400	508	572	800	43	46.9
24#	24.000	300	135,700	24.00	27.75	36.00	1.94	142.0
600	610.0	2065	603865	610	705	914	49	64.4
14 – 24 350 – 600	AGS™		For 14 – 24"/350 – 600 mm sizes Victaulic offers the Advanced Groove System (AGS) line of products, pg. 5-5. Request publication 20.03 for information on the flexible W741 AGS coupling.					

* Refer to Publication 06.06 for more details.

For cut groove systems only. For 14 – 24"/350 – 600 mm roll groove systems, AGS (Advanced Groove System) products are used. Style 741 is not compatible with the AGS system.

IMPORTANT NOTES:

Style 741 Vic-Flange adapters provide rigid joints when used on pipe with standard cut or roll groove dimensions and consequently allow no linear or angular movement at the joint. When used with Victaulic Series 700 butterfly valves, plastic pipe or lightwall metallic pipe, small teeth in I.D. of key section should be removed and may be used on one side of the valve. Contact Victaulic for information on AS2129 - Table E; ISO 2084 (PN10); DIN 2532 (PN10) and JIS B-2210 (10K) flanges. Total bolts required to be supplied by installer, may be ordered from Victaulic.

For restrictions on where and how Vic-Flange adapters and flange washers can be used, refer to Publication 06.06.

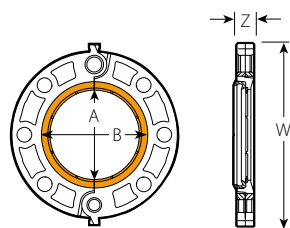

TYPICAL 2–12"/50–300 mm SIZES

Orange area of mating face must be free from gouges, undulations or deformities of any type for effective sealing.

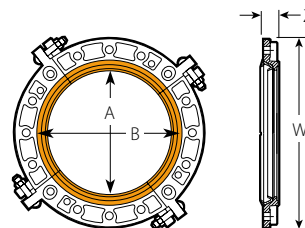

TYPICAL 14–24"/350–600 mm SIZES

Orange area of mating face must be free from gouges, undulations or deformities of any type for effective sealing.

Couplings

Vic-Flange Adapter ANSI Class 300/PN16

STYLE 743

For Complete Information
Request Publication **06.06**



- Permits direct connection of ANSI Class 300 flanged components into a grooved system
- Designed to mate with raised-face flanges, but can be used with flat-face flanges by removing the raised projections on the outside face of the flange
- Pressure rated up to 720psi/4960kPa
- Sizes from 2–12¹/₂–300mm

Size		Max. Work Pressure *	Max. End Load *	Sealing Surface		Dimensions		Approx. Wgt. Each
Nominal Size Inches mm	Actual Outside Dia. Inches mm	psi kPa	Lbs. N	A Max. Inches mm	B Min. Inches mm	W Inches mm	Z Inches mm	Lbs. kg
2	2.375	720	3,190	2.38	3.41	7.70	0.93	4.8
50	60.3	4960	14200	60	87	196	24	2.2
2½	2.875	720	4,670	2.88	3.91	8.61	1.06	7.4
65	73.0	4960	20780	73	99	219	27	3.4
3	3.500	720	6,925	3.50	4.53	9.48	1.18	9.1
80	88.9	4960	30815	89	115	241	30	4.1
4	4.500	720	11,445	4.50	5.53	11.35	1.31	15.3
100	114.3	4960	50930	114	141	288	33	6.9
5	5.563	720	17,500	5.56	6.72	12.31	1.43	17.7
125	141.3	4960	77875	141	171	313	36	8.0
6	6.625	720	24,805	6.63	7.78	13.77	1.50	23.4
150	168.3	4960	110380	168	198	350	38	10.6
8	8.625	720	42,045	8.63	9.94	16.68	1.68	34.3
200	219.1	4960	187100	219	252	424	43	15.6
10	10.750	720	65,315	10.75	12.31	19.25	1.93	48.3
250	273.0	4960	290650	273	313	489	49	21.9
12	12.750	720	91,880	12.75	14.31	22.25	2.06	70.5
300	323.9	4960	408870	324	364	565	52	32.0

* Refer to Publication 06.06 for more details.

IMPORTANT NOTES:

Style 743 Vic-Flange adapters must be ordered as a factory assembly when connected to a Victaulic fitting or valve. Contact Victaulic for details. Total bolts required to be supplied by installer, may be ordered from Victaulic. For restrictions on where and how Vic-Flange adapters and flange washers can be used, refer to Publication 06.06.

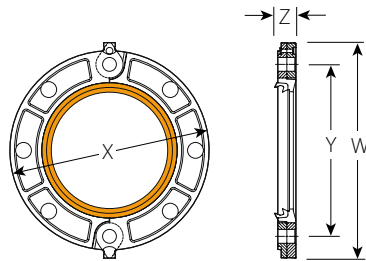

TYPICAL FOR ALL SIZES

Orange area of mating face must be free from gouges, undulations or deformities of any type for effective sealing.

Couplings

COUPLINGS

Reducing Coupling

STYLE 750

For Complete Information
Request Publication **06.08**

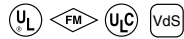

- Direct reduction on the piping run
- Designed to replace two couplings and a reducing fitting
- Special reducing gasket for pressure responsive sealing
- Pressure rated up to 500 psi/3450 kPa
- Sizes from 2 × 1" / 50 × 25mm through 8 × 6" / 200 × 150mm

Size		Max. Work Pressure *	Max. End Load *	Allow. Pipe End Sep. *	Dimensions			Approx. Wgt. Each
Nominal Size	Inches mm	psi	Lbs.	Inches	X	Y	Z	Lbs.
		kPa	N	mm				
2 50	1 25	350	1,000	0 – 0.07	3.38	5.28	1.88	2.7
		2400	4450	0 – 1.8	85	134	48	1.2
	1½ 40	350	1,000	0 – 0.07	3.38	5.28	1.88	2.0
		2400	4450	0 – 1.8	85	134	48	1.0
2½ 65	2 50	500	2,215	0 – 0.07	4.00	5.93	1.88	3.1
		3450	9850	0 – 1.8	102	151	48	1.4
76.1	2 50	350	1,550	0 – 0.07	4.38	6.63	1.88	4.6
		2410	6900	0 – 1.8	111	168	48	2.1
3 80	2 50	350	1,550	0 – 0.07	4.75	7.13	1.88	4.9
		2410	6900	0 – 1.8	121	181	48	2.2
	2½ 65	500	3,250	0 – 0.07	4.75	7.13	1.88	4.3
		3450	14460	0 – 1.8	121	181	48	2.0
88.9	76.1	350	2,275	0 – 0.07	4.75	7.13	1.88	4.2
		2410	10125	0 – 1.8	121	181	48	1.9
4 100	2 50	350	1,550	0 – 0.13	6.25	8.90	2.25	8.1
		2410	6900	0 – 3.2	159	226	57	3.7
	2½ 65	350	2,275	0 – 0.13	6.25	8.90	2.25	8.6
		2410	10125	0 – 3.2	159	226	57	3.9
	3 80	500	4,810	0 – 0.13	6.00	8.90	2.25	6.7
		3450	21400	0 – 3.2	152	226	57	3.0
114.3	76.1	350	2,275	0 – 0.13	6.25	8.90	2.25	6.9
		2410	10125	0 – 3.2	159	226	57	3.1
5 125	4 100	350	5,565	0 – 0.13	7.18	10.70	2.13	11.2
		2410	24765	0 – 3.2	182	272	54	5.1
6 150	4 100	350	5,565	0 – 0.13	8.63	11.90	2.25	16.7
		2410	24765	0 – 3.2	219	302	57	7.6
	5 125	350	8,500	0 – 0.13	8.31	11.90	2.25	12.9
		2410	37825	0 – 3.2	211	302	57	5.9
165.1	4 100	350	5,565	0 – 0.13	8.63	11.90	2.25	15.2
		2410	24765	0 – 3.2	219	302	57	6.9
8 200	6 150	350	12,000	0 – 0.13	10.81	14.88	2.50	22.4
		2410	53400	0 – 3.2	275	378	64	10.2

* Refer to General Notes on pg. 1-4.

IMPORTANT NOTES:

Style 750 reducing couplings should not be used with end caps (No. 60) in systems where a vacuum may be developed. Contact Victaulic for details.

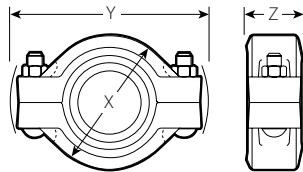

TYPICAL FOR ALL SIZES

Couplings

Snap-Joint Coupling

STYLE 78

For Complete Information
Request Publication **06.09**



- Designed for quick disconnect service
- Mated housings are hinged with an attached locking handle for assembly
- Pressure rated up to 300psi/2065 kPa
- Sizes from 1–8”/25–200mm

Size		Max. Work Pressure *	Max. End Load *	Allow. Pipe End Sep. *	Dimensions			Approx. Wgt. Each
Nominal Size Inches mm	Actual Outside Dia. Inches mm	psi kPa	Lbs. N	Inches mm	X Inches mm	Y Inches mm	Z Inches mm	Lbs. kg
1	1.315	300	410	0 – 0.06	2.75	3.25	1.75	0.8
25	33.4	2065	1825	0 – 1.6	70	83	44	0.4
1¼	1.660	300	650	0 – 0.06	3.13	3.75	1.88	1.1
32	42.2	2065	2890	0 – 1.6	79	95	48	0.5
1½	1.900	300	850	0 – 0.06	3.50	4.50	1.88	1.7
40	48.3	2065	3780	0 – 1.6	89	114	48	0.8
2	2.375	300	1,330	0 – 0.06	4.00	4.75	1.88	1.7
50	60.3	2065	5920	0 – 1.6	102	121	48	0.8
2½	2.875	300	1,950	0 – 0.06	4.75	5.88	1.88	2.5
65	73.0	2065	8680	0 – 1.6	121	149	48	1.1
3	3.500	300	2,885	0 – 0.06	5.38	6.25	1.88	2.8
80	88.9	2065	12840	0 – 1.6	137	159	48	1.3
4	4.500	300	4,770	0 – 0.13	6.88	7.75	2.13	5.5
100	114.3	2065	21225	0 – 3.2	175	197	54	2.5
5	5.563	300	7,290	0 – 0.13	8.75	9.50	2.13	9.8
125	141.3	2065	32440	0 – 3.2	222	241	54	4.4
6	6.625	300	10,350	0 – 0.13	9.88	10.63	2.13	10.7
150	168.3	2065	46060	0 – 3.2	251	270	54	4.9
8	8.625	300	17,500	0 – 0.13	12.25	13.00	2.38	15.3
200	219.1	2065	77875	0 – 3.2	311	330	60	6.9

* Refer to General Notes on pg .1-4.

IMPORTANT NOTES:

Refer to Victaulic Pocket Handbook I-100 for special safety precautions when used for concrete pumping.

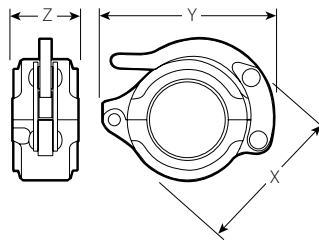

TYPICAL FOR ALL SIZES

Couplings

COUPLINGS

Outlet Coupling

STYLE 72

For Complete Information
Request Publication **06.10**



- Serves dual purpose as a coupling and outlet
- Designed to seal on the joined pipe ends and in the neck of the outlet
- Pressure rated up to 500psi/3450kPa
- Sizes from 1½ × ½" / 40 × 15mm through 6 × 2" / 150 × 50mm

Size	Run × Reducing Outlet Nominal Size Inches/mm	Max. Work Pressure * psi kPa	Allow. Pipe End Sep. * Inches mm	Dimensions					Approx. Wgt. Each Lbs. kg
				T † Inches mm	V § Inches mm	X Inches mm	Y Inches mm	Z Inches mm	
1½ 40	× ½ 15	500	0.75 – 0.88	2.06	2.63	2.94	4.50	2.75	1.4
		3450	19 – 22	52	67	75	114	70	0.6
	× ¾ 20	500	0.75 – 0.88	2.06	2.63	2.94	4.50	2.75	1.4
		3450	19 – 22	52	67	75	114	70	0.6
2 50	× 1 25	500	0.75 – 0.88	1.94	2.63	2.94	4.50	2.75	1.4
		3450	19 – 22	49	67	75	114	70	0.6
	× ½ 15	500	0.81 – 0.88	2.47	3.03	3.38	5.00	2.75	3.5
		3450	20 – 22	63	77	86	127	70	1.6
2½ 65	× ¾ 20	500	0.81 – 0.88	2.47	3.03	3.38	5.00	2.75	2.5
		3450	20 – 22	63	77	86	127	70	1.1
	× 1 25	500	0.81 – 0.88	2.34	3.03	3.38	5.00	2.75	2.5
		3450	20 – 22	60	77	86	127	70	1.1
3 80	× 1¼ 32	500	1.25 – 1.50	3.00	3.69	4.06	6.88	3.25	5.0
		3450	32 – 38	76	94	103	175	83	2.3
	× ½ 40	500	1.25 – 1.50	—	3.69	4.06	6.88	3.25	5.0
		3450	32 – 38	—	94	103	175	83	2.3
4 100	× ¾ 20	500	0.50 – 0.63	2.75	3.31	4.50	7.00	2.38	3.4
		3450	13 – 16	70	84	114	178	60	1.5
	× 1 25	500	1.25 – 1.50	4.06	4.75	4.75	8.00	3.25	7.0
		3450	32 – 38	103	121	121	203	83	3.2
6 150	× 1½ 40	500	1.25 – 1.50	4.06	4.75	4.75	8.00	3.25	7.0
		3450	32 – 38	103	121	121	203	83	3.2
	× 2 50	500	1.25 – 1.50	—	4.25	4.75	8.00	3.25	7.0
		3450	32 – 38	—	108	121	203	83	3.2
4 100	× ¾ 20	500	0.44 – 0.63	3.25	3.81	5.69	8.38	2.50	6.8
		3450	11 – 16	83	97	145	213	64	3.1
	× 1 25	500	0.44 – 0.63	—	3.81	5.69	8.38	2.50	6.8
		3450	11 – 16	—	97	145	213	64	3.1
6 150	× 1½ 40	400	1.63 – 1.81	3.91	4.59	6.13	9.00	3.69	11.4
		2750	41 – 46	99	117	156	229	94	5.2
	× 2 50	400	1.63 – 1.81	—	4.59	6.13	9.00	3.69	11.4
		2750	41 – 46	—	117	156	229	94	5.2
6 150	× 1 25	400	1.63 – 1.81	6.19	6.88	8.13	12.00	3.69	18.0
		2750	41 – 46	157	175	206	305	94	8.2
	× 1½ 40	400	1.63 – 1.81	6.19	6.88	8.13	12.00	3.69	18.0
		2750	41 – 46	157	175	206	305	94	8.2
6 150	× 2 50	400	1.63 – 1.81	—	6.06	8.13	12.00	3.69	18.0
		2750	41 – 46	—	154	206	305	94	8.2

* Refer to General Notes on pg. 1-4.

§ Center of run to end of fittings.

† Center of run to the engaged pipe end. Female threaded outlet only (dimensions approximate).

IMPORTANT NOTES:

No. 60 Cap is not for use in vacuum services with Style 72 or 750 couplings. No. 61 bull plug should be used.

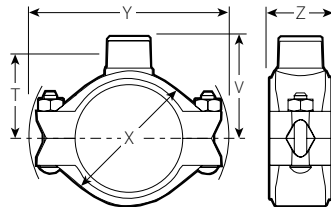

TYPICAL FOR ALL SIZES

Couplings

Vic-Boltless Coupling

STYLE 791 AND STYLE 792 ASSEMBLY TOOL

For Complete Information Request Publication 06.11



- One-piece hinged coupling
- Features locking pin installation with a separate tool (Style 792) designed for assembly and disassembly
- Provides secure, tamper resistant, low profile joint
- Pressure rated up to 700psi/4825kPa
- Sizes from 2–8"/50–200mm

Size		Max. Work Pressure *	Max. End Load *	Allow. Pipe End Sep. *	Locking Pin Size	Dimensions			Approx. Wgt. Each
Nominal Size Inches mm	Actual Outside Dia. Inches mm	psi kPa	Lbs. N	Inches mm	Dia. x Length Inches mm	X Inches mm	Y Inches mm	Z Inches mm	Lbs. kg
2 50	2.375 60.3	700 4825	3,100 13795	0 – 0.06 0 – 1.6	5/16 x 1 7/8 8 x 48	3.56 90	4.71 120	1.84 47	1.8 0.8
2 1/2 65	2.875 73.0	700 4825	4,540 20205	0 – 0.06 0 – 1.6	3/8 x 1 7/8 10 x 48	4.09 104	5.48 139	1.84 47	2.7 1.2
3 80	3.500 88.9	700 4825	6,730 29950	0 – 0.06 0 – 1.6	3/8 x 1 7/8 10 x 48	4.72 120	6.15 156	1.84 47	2.6 1.2
4 100	4.500 114.3	700 4825	11,130 49530	0 – 0.13 0 – 3.2	7/16 x 2 11 x 51	6.06 154	7.62 194	1.93 49	4.8 2.2
6 150	6.625 168.3	600 4135	20,675 92005	0 – 0.13 0 – 3.2	1/2 x 2 1/16 13 x 52	8.24 209	10.18 259	2.06 51	6.3 2.9
8 200	8.625 219.1	500 3450	29,200 129940	0 – 0.13 0 – 3.2	1/2 x 2 5/16 13 x 59	10.52 267	12.50 318	2.31 59	12.0 5.4

* Refer to General Notes on pg.1-4.

IMPORTANT NOTES:

Complete coupling includes one-piece hinged housing, gasket and locking pin only. Assembly tool Style 792 is required for assembly (one tool fits all size couplings).

Please see Publication 06.11 for tool clearance dimensions.

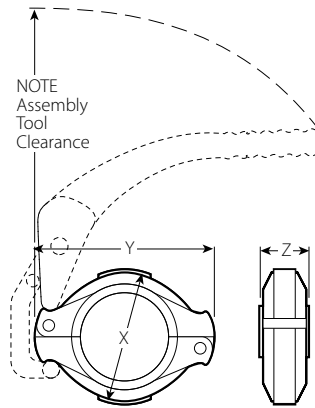

TYPICAL FOR ALL SIZES

Couplings

COUPLINGS

Rigid Coupling

STYLE HP-70

For Complete Information
Request Publication **06.12**



- Designed with heavy housing for high pressure services
- Housing key is wider than standard
- Coupling housing is designed to clamp the bottom of the groove
- Essentially rigid joint
- Pressure rated up to 1000psi/6900kPa
- Sizes from 2–16"/50–400mm

Size		Max. Work Pressure *	Max. End Load *	Allow. Pipe End Sep. *	Dimensions			Approx. Wgt. Each
Nominal Size Inches mm	Actual Outside Dia. Inches mm	psi kPa	Lbs. N	Inches mm	X Inches mm	Y Inches mm	Z Inches mm	Lbs. kg
2	2.375	1000	4,430	0.14	3.50	6.68	2.00	3.2
50	60.3	6900	19715	3.6	89	168	51	1.5
2½	2.875	1000	6,490	0.14	4.13	7.13	2.00	4.0
65	73.0	6900	28881	3.6	105	181	51	1.8
3	3.500	1000	9,620	0.14	4.75	7.75	2.00	4.4
80	88.9	6900	42810	3.6	121	197	51	2.0
4	4.500	1000	15,900	0.25	6.00	9.63	2.13	7.5
100	114.3	6900	70755	6.4	152	245	54	3.4
6	6.625	1000	34,470	0.25	8.63	12.68	2.50	16.0
150	168.3	6900	153390	6.4	219	321	64	7.3
8	8.625	800	46,740	0.25	11.00	15.00	2.75	26.1
200	219.1	5500	207995	6.4	279	381	70	11.8
10	10.750	800	72,640	0.25	13.50	17.25	3.00	32.8
250	273.0	5500	323250	6.4	343	438	76	14.9
12	12.750	800	102,000	0.25	15.63	19.13	3.13	46.0
300	323.9	5500	453900	6.4	397	486	80	20.9
14 #	14.000	600	92,360	0.25	16.75	22.00	3.88	64.0
350	355.6	4100	410800	6.4	425	559	99	29.0
16 #	16.000	600	120,600	0.25	18.75	24.13	3.88	72.0
400	406.4	4100	536400	6.4	476	613	99	32.7

These sizes are not UL Listed or FM Approved. These sizes are not intended for use on AGS roll groove pipe.

* Refer to General Notes on pg. 1-4.

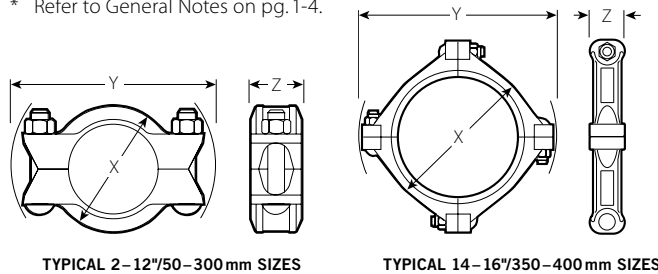

Couplings

High Pressure Coupling

STYLE 808

For Complete Information Request Publication 15.01.

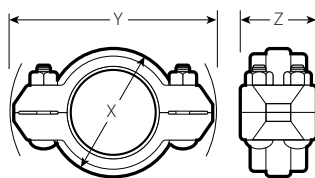

Typical for all sizes

- Style 808 provides superior joint integrity at high pressures while maintaining a degree of flexibility to facilitate joining.
- Couplings engage directly into double grooved pipe without the need for special weld-on nipples or collars.
- Available for 6-12"/150-300mm
- Pressure rated up to 4000psi/27586kPa

DIMENSIONS

Pipe Size		Dimensions – Inches/mm			Bolt/Nut		Min.	Approx.
Nominal Size Inches mm	Actual Outside Diameter Inches mm	X	Y	Z	No.	Diameter X Length	Bolt Torque @ Lb. Ft. N•m	Wgt. Each Lbs. kg
6 150	6.625 168.3	8.75 222	13.81 351	5.00 127	4	1 x 5	450 610	36.0 16.3
8 200	8.625 219.1	11.18 284	16.08 408	5.75 146	4	1 ½ x 6	500 678	70.0 31.8
10 250	10.750 273.0	13.44 341	18.68 473	6.38 162	4	1 ½ x 6	500 678	85.0 38.6
12* 300	12.750 323.9	—	—	—	—	—	—	—

@ To achieve adequate tension on the bolts this is the minimum torque which must be applied.

*Available as special order item. Please contact Victaulic Engineered Products.

PERFORMANCE DATA

1		2		3	4	5	6		7	8		9
Pipe Size		Nominal Steel Pipe Dimension Inches mm			A Max. Joint Work. Press.	Max. Permiss. End Load	B, C Pipe End Sep. Standard Gasket Min. – Max.		B, C Pipe End Sep. “ES” Gasket Min. – Max.	B, C Max. Deflection From Center Line		
Nominal Size Inches mm	Actual Outside Diameter Inches mm	Wall Thick.	Sched. No.	psi kPa	Lbs. N	Inches mm		Inches mm	Degrees Per Cplg.	Pipe In./Ft. mm/m		
6 150	6.625 168.3	0.432 11.0	80	3000 20690	103.410 459968	0.258 – 0.438 6.6 – 11.1		0.298 – 0.478 7.6 – 12.1	1° – 33'	0.35 29.2		
6 150	6.625 168.3	0.719 18.3	160	4000 27586	137.880 613290	0.258 – 0.438 6.6 – 11.1		0.298 – 0.478 7.6 – 12.1		0.35 29.2		
8 200	8.625 219.1	0.500 12.7	80	2500 17241	146.060 649675	0.188 – 0.438 4.8 – 11.1		0.260 – 0.510 6.6 – 13.0	1° – 39'	0.35 29.2		
8 200	8.625 219.1	0.906 23.0	160	3500 24138	204.490 909572	0.188 – 0.438 4.8 – 11.1		0.260 – 0.510 6.6 – 13.0		0.35 29.2		
10 250	10.750 273.0	0.593 15.1	80	2500 17241	226.900 1009251	0.188 – 0.438 4.8 – 11.1		0.260 – 0.510 6.6 – 13.0	1° – 20'	0.28 23.3		
10 250	10.750 273.0	1.125 28.6	160	3000 20690	272.280 1211101	0.188 – 0.438 4.8 – 11.1		0.260 – 0.510 6.6 – 13.0		0.28 23.3		
12 300	12.750 323.9	0.688 17.5	80	2000 13793	255.350 1135797	0.188 – 0.438 4.8 – 11.1		0.260 – 0.510 6.6 – 13.0	1° – 07"	0.24 20.0		
12 300	12.750 323.9	1.312 33.3	160	2500 17241	319.190 1419757	0.188 – 0.438 4.8 – 11.1		0.260 – 0.510 6.6 – 13.0		0.24 20.0		

COLUMN 1 – Victaulic couplings are identified by nominal pipe size.

COLUMN 2 – Nominal pipe wall thickness. For data with other wall thicknesses contact Victaulic.

COLUMN 3 – Pipe wall thickness schedule as established by ANSI Standard B36.10.

COLUMN 4 – Maximum line pressure, including surge, to which a joint should be subjected. This figure provides a nominal safety factor of 3. Working pressure ratings are based on pipe prepared in accordance with Victaulic double cut groove specifications. Maximum allowable working pressures for other pipe schedules or grades must be determined by applicable code requirements.

NOTE A: ONE TIME FIELD TEST ONLY. The Maximum Joint Working Pressure may be increased to 1 ½ times the figures shown.

COLUMN 5 – Maximum end load from all internal and/or external forces to which the joint should be subjected under working conditions.

COLUMNS 6 & 7 – Range of pipe end separation normally available on double cut groove steel pipe. Maximum allowable movement is the difference between minimum and maximum pipe end separation subject to tolerances (see Design Data).

COLUMNS 8 & 9 – Maximum allowable deflection of pipe from centerline, subject to tolerances (see Design Data). See Note B.

NOTE B: Maximum Pipe Movement will be reduced by Deflection (Col. 8 & 9) and vice versa.

NOTE C: Refer to Design Data for information on tolerances and pipe gap settings.

Couplings

Endseal Coupling for Plastic Coated Pipe

STYLE HP-70ES

For Complete Information
Request Publication **06.13**

COUPLINGS



- Specially formulated and compounded oil-resistant nitrile gasket
- ES gasket design has integral central leg that positions between the pipe ends for use with plastic-coated or cement-lined pipe
- Designed for higher pressure systems rated up to 2500psi/17250kPa
- Sizes from 2–12”/50–300mm

Size		Max. Work Pressure *	Max. End Load *	Allow. Pipe End Sep. *	Dimensions			Approx. Wgt. Each
Nominal Size Inches mm	Actual Outside Dia. Inches mm	psi kPa	Lbs. N	Inches mm	X Inches mm	Y Inches mm	Z Inches mm	Lbs. kg
2	2.375	2500	11,000	0.19	3.44	6.51	1.88	3.2
50	60.3	17250	48950	4.8	87	765	48	1.5
2½	2.875	2500	16,200	0.19	4.00	7.10	1.88	4.0
65	73.0	17250	72090	4.8	102	180	48	1.8
3	3.500	2500	25,400	0.19	4.69	7.74	1.88	4.6
80	88.9	17250	113030	4.8	119	197	48	2.1
4	4.500	2500	39,000	0.19	5.94	9.54	2.13	8.2
100	114.3	17250	173550	4.8	151	242	54	3.7
6	6.625	2000	68,800	0.27	8.50	12.61	2.38	16.4
150	168.3	13800	306160	6.7	216	320	60	7.4
8	8.625	1500	87,500	0.27	10.94	14.97	2.75	26.0
200	219.1	10350	389375	6.7	278	380	70	11.8
10	10.750	1250	114,500	0.28	13.43	17.22	2.88	37.2
250	273.0	8600	509525	7.1	341	437	73	16.9
12	12.750	1250	160,800	0.28	15.56	19.06	3.00	42.0
300	323.9	8600	715560	7.1	395	484	76	19.1

* Refer to General Notes on pg. 1-4.

IMPORTANT NOTES:

HP-70ES couplings must always be used with pipe or fittings grooved to Victaulic “ES” dimensions.
HP-70ES couplings cannot be used with Victaulic Series 700 butterfly valves.

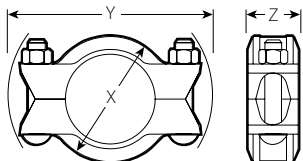

TYPICAL FOR ALL SIZES

Couplings – EndSeal Fittings

EndSeal Fittings for Plastic Coated Pipe

- NO. 62-ES** 90° Elbow
- NO. 63-ES** 45° Elbow
- NO. 64-ES** Tee
- NO. 35-ES** Cross
- NO. 22-ES** Header Tee

For Complete Information
Request Publication **07.03**



- Extra heavy wall thickness – Schedule 80
- “ES” EndSeal grooves for use with HP-70ES couplings only
- Special header tees for oil production headers designed with top (test) line is 2”/50mm and bottom production line is 3”/80mm or 4”/100mm
- Sizes from 2–6”/50–150mm

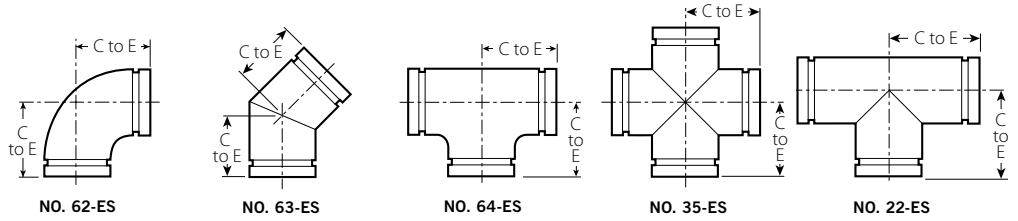

Size		No. 62-ES 90° Elbow		No. 63-ES* 45° Elbow		No. 64-ES* Tee		No. 35-ES* Cross		No. 22-ES Header Tee	
Nominal Size Inches mm	Actual Outside Diameter Inches mm	C to E Inches mm	Approx. Weight Each Lbs. kg	C to E Inches mm	Approx. Weight Each Lbs. kg	C to E Inches mm	Approx. Weight Each Lbs. kg	C to E Inches mm	Approx. Weight Each Lbs. kg	C to E Inches mm	Approx. Weight Each Lbs. kg
2 50	2.375 60.3	3.25 83	2.5 1.1	2.00 51	1.8 0.8	3.25 83	4.2 1.9	3.25 83	3.9 1.8	—	—
2½ 65	2.875 73.0	3.75 95	5.0 2.3	2.25 57	2.9 1.3	3.75 95	7.9 3.6	3.75 95	6.6 3.0	—	—
2 – 3 50 – 90	2.375 – 3.500 60.3 – 88.9	—	—	—	—	—	—	—	—	4.25 108	3.4 1.5
2 – 4 50 – 100	2.375 – 4.500 60.3 – 114.3	—	—	—	—	—	—	—	—	5.00 127	4.1 1.9
3 80	3.500 88.9	4.25 108	6.0 2.7	2.50 64	4.3 1.9	4.25 108	16.0 7.3	4.25 108	14.2 6.4	—	—
4 100	4.500 114.3	5.00 127	10.3 4.7	3.00 76	8.5 3.9	5.00 127	23.5 10.7	5.00 127	15.8 7.2	—	—
6 † 150	6.625 168.3	6.50 165	27.2 12.3	3.50 89	16.5 7.5	6.50 165	27.0 12.2	6.50 165	46.0 20.9	—	—

* Steel Fabricated - Cast Full Flow.

† For sizes to 12”/300mm consult Victaulic.

IMPORTANT NOTES:

Steel Full Flow elbows available with longer center to end dimensions. Contact Victaulic for details.

Fittings

- Fittings available in sizes through 48"/1200mm
- Standard fitting pressure ratings conform to ratings of installed coupling
- All fittings supplied with grooves or shoulders for fast installation
- Groove design permits flexibility for easy alignment (these fittings are not intended for use with Victaulic couplings for plain end pipe – refer to Publication 14.04 for fittings available for plain end pipe)
- Painted orange enamel with optional galvanized finish
- When connecting wafer or lug-type butterfly valves directly to Victaulic fittings with Style 741 or 743 Vic-Flange adapters, check disk clearance dimensions with I.D. dimension of fitting
- Request Publication 07.01

Advanced Groove System **AGS™**



For 14–24"/350–600 mm piping systems Victaulic offers Advanced Groove System (AGS) fittings, see pg 5-1.

Tees, Crosses, Wyes, and Laterals

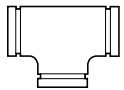

Tee
NO. 20, PG. 2-6
AGS NO. W20, PG. 5-6

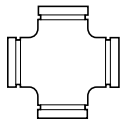

Cross
NO. 35, PG. 2-6
AGS NO. W35, PG. 5-6

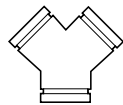

True Wye
NO. 33, PG. 2-6
AGS NO. W33, PG. 5-6



Standpipe Tee
NO. 27, PG. 2-8

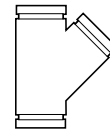

45° Lateral
NO. 30, PG. 2-9
AGS NO. W30, PG. 5-7

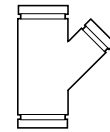

45° Reducing Lateral
NO. 30-R, PG. 2-9
AGS NO. W30-R, PG. 5-7

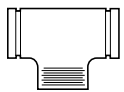

Tees with Threaded Branch
NO. 29M, PG. 2-6

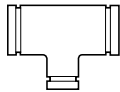

Reducing Tee
NO. 25, PGS. 2-7, 8
AGS NO. W25, PG. 5-6

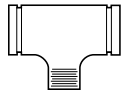

Reducing Tee with Threaded Branch
NO. 29, PGS. 2-7, 8

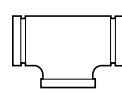

Bullhead Tee
NO. 21, PG. 2-8

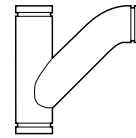

Tee Wye
NO. 32, PG. 2-10

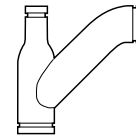

Reducing Tee Wye
NO. 32-R, PG. 2-10

FITTINGS

Elbows



90° Elbow
NO. 10, PG. 2-3
AGS NO. W10, PG. 5-6

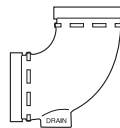

Drain Elbow
NO. 10-DR, PG. 2-4

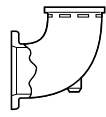

Reducing Base Support Elbow Grv. x Flange
NO. R-10F, PG. 2-4

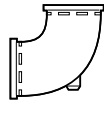

Reducing Base Support Elbow Grv. x Grv.
NO. R-10G, PG. 2-4

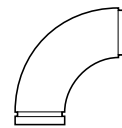

90° 1½ D Long Radius Elbow
NO. 100, PG. 2-3
AGS NO. W100, PG. 5-6

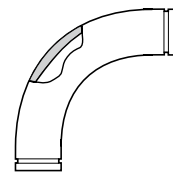

90° 3 D Long Radius Elbow
NO. 100-3D, PG. 2-4



45° Elbow
NO. 11, PG. 2-3
AGS NO. W11, PG. 5-6



45° 1½ D Long Radius Elbow
NO. 110, PG. 2-3
AGS NO. W110, PG. 5-6



45° 3 D Long Radius Elbow
NO. 110-3D, PG. 2-4

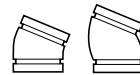

22½° Elbow
NO. 12, PG. 2-3
AGS NO. W12, PG. 5-6



11¼° Elbow
NO. 13, PG. 2-3
AGS NO. W13, PG. 5-6

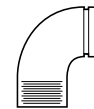

90° Adapter Elbow
NO. 18, PG. 2-5



45° Adapter Elbow
NO. 19, PG. 2-5

Fittings

Alternate Style Fittings Machined for Rubber or Urethane Lining

- For severe abrasive services
- Fitting may be rubber or urethane lined
- Refer to Publication 25.03 for specific details

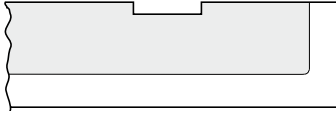

FOR ABRASION RESISTANCE ONLY



FOR CORROSION AND/OR ABRASION RESISTANCE

Adapters, Nipples, Caps, and Plugs



Adapter Nipple
Grv. × Thd.
NO. 40, PG. 2-11



Adapter Nipple
Grv. × Bev.
NO. 42, PG. 2-11
AGS NO. W42, PG. 5-9



Adapter Nipple
Grv. × Grv.
NO. 43, PG. 2-11
AGS NO. W43, PG. 5-9
AGS NO. W49, PG. 5-9



Flat Face Flanged
Adapter Nipple
NO. 41, NO. 45F,
NO. 46F, PG. 2-12



Raised Face Flanged
Adapter Nipple
NO. 45R, NO. 46R,
PG. 2-12
AGS NO. W45R, PG. 5-9



Female Threaded
Adapter
NO. 80, PG. 2-14



Swaged Nipple
Grv. × Grv.
NO. 53, PG. 2-13



Swaged Nipple
Grv. × Thd.
NO. 54, PG. 2-13



Swaged Nipple
Thd. × Grv.
NO. 55, PG. 2-13



Bull Plug
NO. 61, PG. 2-8



Cap
NO. 60, PG. 2-11
AGS NO. W60, PG. 5-9



Hose Nipple
NO. 48, PG. 2-14

Reducers

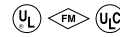

Concentric
Reducer
NO. 50, PG. 2-15
AGS NO. W50, PG. 5-10



Eccentric
Reducer
NO. 51, PG. 2-15
AGS NO. W51, PG. 5-10



Small Threaded
Reducer
NO. 52, PG. 2-16

PRODUCTS

- 1-1 Couplings
- 2-1 Fittings**
- 3-1 Valves
- 4-1 Accessories
- 5-1 Advanced Groove System
- 6-1 Hole Cut Piping System
- 7-1 Plain End Piping System
- 8-1 Grooved System for Stainless Steel Pipe
- 9-1 Pressfit System for Stainless Steel Pipe
- 10-1 Plain End Piping System for HDPE Pipe
- 11-1 Grooved Copper
- 12-1 PermaLynx System for Copper Tube
- 13-1 Grooved AWWA Ductile Iron Pipe
- 14-1 Victaulic Depend-O-Lok® System
- 15-1 Aquamine Reusable PVC Products
- 16-1 Gaskets
- 17-1 Pipe Preparation Tools
- 18-1 Product Index
- 19-1 Piping Software

Fittings

Elbows

NO. 10 90° Elbow

NO. 11 45° Elbow

NO. 12 22½° Elbow

NO. 13 11¼° Elbow

NO. 100 90° LR Elbow

NO. 110 45° LR Elbow
(Ductile Iron#)

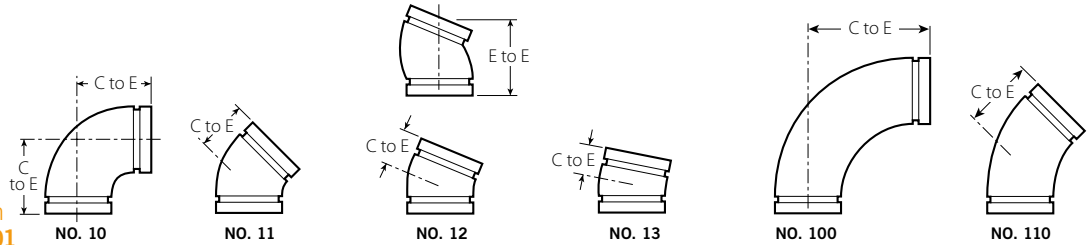

For Complete Information
Request Publication **07.01**

Size		No. 10 90° Elbow		No. 11 45° Elbow		No. 12 22½° Elbow		No. 13 11¼° Elbow		No. 100 (1½ D) 90° Long Radius Elbow		No. 110 (1½ D) 45° Long Radius Elbow	
Nominal Size Inches mm	Actual Outside Dia. Inches mm	C to E Inches mm	Approx. Wgt. Each Lbs. kg	C to E Inches mm	Approx. Wgt. Each Lbs. kg	C to E Inches mm	Approx. Wgt. Each Lbs. kg	C to E Inches mm	Approx. Wgt. Each Lbs. kg	C to E Inches mm	Approx. Wgt. Each Lbs. kg	C to E Inches mm	Approx. Wgt. Each Lbs. kg
¾	1.050	2.25	0.5	1.50	0.5	1.63 (sw)	—	1.38 (sw)	—	—	—	—	—
20	26.9	57	0.2	38	0.2	41	—	35	—	—	—	—	—
1	1.315	2.25	0.6	1.75	0.6	3.25 @	0.6	1.38 (sw)	0.3	—	—	—	—
25	33.7	57	0.3	44	0.3	83	0.3	35	0.1	—	—	—	—
1¼	1.660	2.75	1.0	1.75	0.9	1.75	0.8	1.38 (sw)	0.5	—	—	—	—
32	42.4	70	0.5	44	0.4	44	0.4	35	0.2	—	—	—	—
1½	1.900	2.75	1.2	1.75	0.9	1.75	0.8	1.38 (sw)	0.5	—	—	—	—
40	48.3	70	0.5	44	0.4	44	0.4	35	0.2	—	—	—	—
2	2.375	3.25	1.8	2.00	1.3	3.75 @	1.4	1.38	1.0	4.38	2.5	2.75	1.8
50	60.3	83	0.8	51	0.6	95	0.6	35	0.5	111	1.1	70	0.8
2½	2.875	3.75	3.2	2.25	2.2	4.00 @	2.3	1.50	1.1	5.13	4.1	3.00	2.8
65	73.0	95	1.5	57	1.0	102	1.0	38	0.5	130	1.9	76	1.3
76.1 mm	3.000	3.75	3.7	2.25	3.4	2.24	—	1.50	—	—	—	—	—
	76.1	95	1.7	57	1.5	57	—	38	—	—	—	—	—
3	3.500	4.25	4.5	2.50	3.1	4.50 @	3.1	1.50	2.1	5.88	6.0	3.38	4.9
80	88.9	108	2.0	64	1.4	114	1.4	38	1.0	149	2.7	86	2.2
3½	4.000	4.50	5.6	2.75	4.3	2.50 (sw)	4.0	1.75 (sw)	2.7	—	—	—	—
90	101.6	114	2.5	70	2.0	64	1.8	44	1.2	—	—	—	—
4	4.500	5.00	7.1	3.00	5.6	2.88	5.6	1.75	3.6	7.50	12.3	4.00	7.3
100	114.3	127	3.2	76	2.5	73	2.5	44	1.6	191	5.6	102	3.3
108.0 mm	4.250	5.00	11.0	3.00	5.6	—	—	—	—	—	—	—	—
	108.0	127	5.0	76	2.5	—	—	—	—	—	—	—	—
4½	5.000	5.25 (sw)	10.0	3.13 (sw)	6.0	3.50	6.6	1.88 (sw)	4.2	—	—	—	—
120	127.0	133	4.5	79	2.7	89	3.0	48	1.9	—	—	—	—
5	5.563	5.50	11.7	3.25	8.3	2.88 (sw)	7.8	2.00 (sw)	5.0	+	18.2	+	14.8
125	141.3	140	5.3	83	3.8	73	3.5	51	2.2	—	8.3	—	6.7
133.0 mm	5.250	5.50	11.7	3.25	8.3	—	—	—	—	—	—	—	—
	133.0	140	5.3	83	3.8	—	—	—	—	—	—	—	—
139.7 mm	5.500	5.50	11.7	3.25	8.3	2.87	—	2.00	—	—	—	—	—
	139.7	140	5.3	83	3.8	73	—	51	—	—	—	—	—
6	6.625	6.50	17.2	3.50	10.8	6.25 @	12.2	2.00	7.0	10.75	30.4	5.50	17.4
150	168.3	165	7.8	89	4.9	159	5.5	51	3.2	273	13.8	140	7.9
159.0 mm	6.250	6.50	18.6	3.50	10.8	—	—	—	—	—	—	—	—
	159.0	165	8.4	89	4.9	—	—	—	—	—	—	—	—
165.1 mm	6.500	6.50	15.5	3.50	9.8	3.13	11.4	2.00	7.4	10.75	29.0	5.50	19.0
	165.1	165	7.0	89	4.4	79	5.2	51	3.4	273	13.2	140	8.6
8	8.625	7.75	29.9	4.25	20.4	7.75 @	20.0	2.00	10.1	14.25	66.0	7.25	36.0
200	219.1	197	13.6	108	9.3	197	9.1	51	4.6	362	30.0	184	16.3
10	10.750	9.00	63.3	4.75	37.5	4.38 (sw)	30.0	2.13 (sw)	11.8	15.00	107.0	6.25	57.0
250	273.0	229	28.7	121	17.0	111	13.6	54	5.3	381	48.5	159	25.9
12	12.750	10.00	74.0	5.25	66.7	4.88 (sw)	40.0	2.25 (sw)	29.3	18.00	156.0	7.50	90.0
300	323.9	254	33.6	133	30.3	124	18.1	57	13.3	457	70.8	191	40.8
14 – 24 350 – 600		AGS™ See AGS Roll Groove Fittings, pg. 5-2; for 14–24"/350–600mm Cut Groove Systems Request Publication 07.01											

@ Gooseneck design, end-to-end dimension.

+ Contact Victaulic for details.

Ductile iron except those marked (sw) which are segmentally welded steel.

Fittings

No. 10-DR Drain Elbow

NO. 10-DR Drain Elbow
(Ductile Iron)

For Complete Information
Request Publication **10.05**

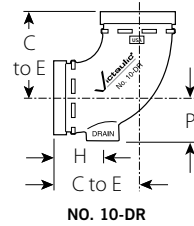

NO. 10-DR

Size		Dimensions inches/mm			
Nominal Size Inches mm	Actual Outside Dia. Inches mm	C to E	H	P	
2½ 65	2.875 73.0	3.75 95.3	2.75 69.9	1.68 42.7	
3 80	3.500 88.9	4.25 108.0	2.75 69.9	2.10 53.3	
4 100	4.500 114.3	5.00 127.0	2.75 69.9	2.60 66.0	
6 150	6.625 168.3	6.50 165.1	2.75 69.9	3.65 89	

NOTE: The drain is drilled and tapped for a 1-inch/25-mm NPT outlet.

Long Radius Elbow 3D

With added wall thickness
at bend for abrasive services.

NO. 100-3D 90° Long Radius Elbow 3D
NO. 110-3D 45° Long Radius Elbow 3D
(Ductile Iron)

For Complete Information
Request Publication **07.01**

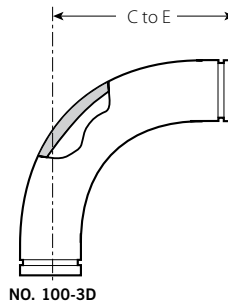

NO. 100-3D

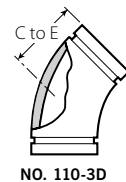

NO. 110-3D

Size		Wall Thickness			No. 100-3D 90° Long Radius Elbow		No. 110-3D 45° Long Radius Elbow	
Nominal Size Inches mm	Actual Outside Diameter Inches mm	In Non-critical Area Inches mm	At Back Wear Area Inches mm	Extra Inches mm	C to E Inches mm	Approx. Weight Each Lbs. kg	C to E Inches mm	Approx. Weight Each Lbs. kg
2 50	2.375 60.3	0.184 4.67	0.309 7.85	0.125 3.18	10.00 254	5.0 2.3	6.50 165	4.7 2.1
3 80	3.500 88.9	0.246 6.25	0.371 9.42	0.125 3.18	13.00 330	16.0 7.3	7.75 197	10.4 4.7
4 100	4.500 114.3	0.267 6.78	0.455 11.56	0.188 4.78	16.00 406	25.5 11.6	9.00 229	17.2 7.8
6 150	6.625 168.3	0.310 7.87	0.560 14.22	0.250 6.35	24.00 610	70.0 31.8	13.50 343	45.0 20.4

Reducing Base Support Elbow

NO. R-10G Grv. × Grv.
NO. R-10F Grv. × Flange
(Ductile Iron)

For Complete Information
Request Publication **07.01**

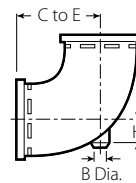

NO. R-10G

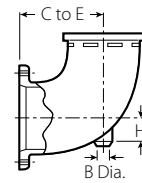

NO. R-10F

Size		No. R-10 Reducing Base Support Elbow			Approx. Weight Each	
Nominal Size Inches mm		C to E Inches mm	H Inches mm	B Diameter Inches mm	Grv. × Grv. Lbs. kg	Grv. × Flange Lbs. kg
6 150	4 100	9.00 229	1.25 32	1.50 38	19.0 8.6	33.0 15.0
	5 125	9.00 229	1.50 38	1.50 38	23.0 10.4	38.0 17.2
8 200	6 150	10.50 267	2.13 54	1.50 38	33.0 15.0	52.0 23.6
10 250	8 200	12.00 305	2.40 61	1.50 38	61.0 27.7	88.0 39.9

Fittings

Adapter Elbow

NO. 18 90° Adapter Elbow

NO. 19 45° Adapter Elbow
(Ductile Iron)

For Complete Information
Request Publication **07.01**

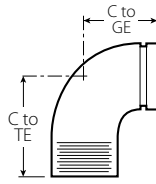

NO. 18

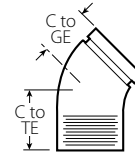

NO. 19

Size		No. 18 90° Adapter Elbow @			No. 19 45° Adapter Elbow @		
Nominal Size Inches mm	Actual Outside Diameter Inches mm	C to GE Inches mm	C to TE Inches mm	Approx. Weight Each Lbs. kg	C to GE Inches mm	C to TE Inches mm	Approx. Weight Each Lbs. kg
3/4 20	1.050 26.9	2.25 57	2.25 57	0.5 0.2	1.50	1.50	0.5
1 25	1.315 33.7	2.25 57	2.25 57	0.5 0.2	—	—	—
1 1/4 32	1.660 42.4	2.75 70	2.75 70	0.9 0.4	—	—	—
1 1/2 40	1.900 48.3	2.75 70	2.75 70	1.1 0.5	1.75 44	1.75 44	0.9 0.4
2 50	2.375 60.3	3.25 83	4.25 108	2.5 1.1	—	—	—
2 1/2 65	2.875 73.0	3.75 95	3.75 95	3.0 1.4	2.25 57	2.25 57	2.3 1.0
3 80	3.500 88.9	4.25 108	6.00 152	5.8 2.6	2.50 64	4.25 108	5.0 2.3
3 1/2 90	4.000 101.6	4.50 114	6.25 159	8.0 3.6	5.25 133	5.25 133	8.8 4.0
6 150	6.625 168.3	6.50 165	6.50 165	17.6 8.0	3.50 89	3.50 89	12.7 5.8

@ Available with British Standard Pipe Threads, specify "BSP" clearly on order.

Fittings

Tees, Crosses and True Wyes

NO. 20 Tee

NO. 35 Cross

NO. 33 True Wye

NO. 29M Tee with
Threaded Branch
(Ductile Iron#)

For Complete Information
Request Publication **07.01**

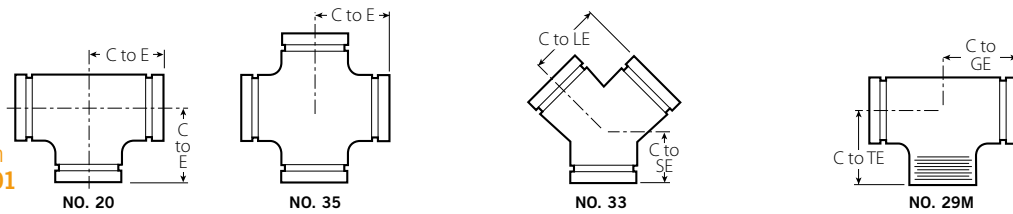

Size		No. 20 Tee		No. 35 Cross (sw)		No. 33 True Wye (sw)			No. 29M Tee with Threaded Branch		
Nominal Size Inches mm	Actual Outside Dia. Inches mm	C to E Inches mm	Approx. Weight Each Lbs. kg	C to E Inches mm	Approx. Weight Each Lbs. kg	C to LE Inches mm	C to SE Inches mm	Approx. Weight Each Lbs. kg	C to GE Inches mm	C to TE Inches mm	Approx. Weight Each Lbs. kg
3/4 20	1.050 26.9	2.25 57	0.6 0.3	2.25 57	0.9 0.4	—	—	—	2.25 57	2.25 57	0.6 0.3
1 25	1.315 33.7	2.25 57	1.0 0.5	2.25 57	1.3 0.6	2.25 57	2.25 57	1.1 0.5	—	—	—
1 1/4 32	1.660 42.4	2.75 70	1.5 0.7	2.75 70	2.1 1.0	2.75 70	2.50 64	1.5 0.7	2.75 70	2.75 70	1.5 0.7
1 1/2 40	1.900 48.3	2.75 70	2.0 0.9	2.75 70	2.5 1.1	2.75 70	2.75 70	1.8 0.8	2.75 70	2.75 70	2.0 0.9
2 50	2.375 60.3	3.25 83	3.0 1.4	3.25 83	3.8 1.7	3.25 83	2.75 70	2.5 1.1	3.25 83	4.25 108	3.00 1.4
2 1/2 65	2.875 73.0	3.75 95	4.3 2.0	3.75 95	6.1 2.8	3.75 95	3.00 76	4.3 2.0	—	—	—
76.1 mm	3.000 76.1	3.75 95	5.2 2.4	—	—	—	—	—	3.75(sw) 95	3.75 95	5.2 2.4
3 80	3.500 88.9	4.25 108	6.8 3.0	4.25 108	10.5 4.8	4.25 108	3.25 83	6.1 2.8	—	—	—
3 1/2 90	4.000 101.6	4.50(sw) 114	7.9 3.6	4.50 114	11.5 5.2	4.50 114	3.50 89	9.6 4.4	4.50(sw) 114	4.50 114	7.9 3.6
4 100	4.500 114.3	5.00 127	11.9 5.4	5.00 127	15.8 7.2	5.00 127	3.75 95	10.0 4.5	5.00 127	7.25 184	11.9 5.4
108.0mm	4.250 108.0	5.00 127	15.5 7.0	—	—	—	—	—	5.00 127	5.00 127	15.5 7.0
4 1/2 120	5.000 127.0	5.25(sw) 133	15.0 6.8	5.25 133	18.5 8.4	—	—	—	5.25(sw) 133	5.25 133	15.0 6.8
5 125	5.563 141.3	5.50 140	17.8 8.1	5.50 140	20.0 9.1	5.50 140	4.00 102	15.0 6.8	5.50(sw) 140	5.50 140	17.8 8.1
133.0mm	5.250 133.0	5.50 140	17.8 8.1	—	—	—	—	—	5.50 140	5.50 140	17.8 8.1
139.7 mm	5.500 139.7	5.50 140	17.8 8.1	—	—	—	—	—	5.50 140	5.50 140	17.8 8.1
6 150	6.625 168.3	6.50 165	25.7 11.7	6.50 165	28.0 12.7	6.50 165	4.50 114	22.3 10.1	6.50(sw) 165	6.50 165	25.7 11.7
159.0mm	6.250 159.0	6.50 165	27.1 12.3	—	—	—	—	—	6.50 165	6.50 165	27.1 12.3
165.1 mm	6.500 165.1	6.50 165	22.0 10.0	6.50 165	28.0 12.7	—	—	—	6.50 165	6.50 165	22.0 10.0
8 200	8.625 219.1	7.75 197	47.6 21.6	7.75 197	48.0 21.8	7.75 197	6.00 152	36.0 16.3	7.75(sw) 197	7.75 197	47.6 21.6
10 250	10.750 273.0	9.00 229	99.0 44.9	9.00 229	121.5 55.1	9.00 229	6.50 155	69.9 31.7	9.00 229	9.00 229	73.0 33.1
12 300	12.750 323.9	10.00 254	133.0 60.3	10.00 254	110.0 49.9	10.00 254	7.00 178	80.0 36.3	10.00 254	10.00 254	99.0 44.9
14 – 24 350 – 600	AGS™ See AGS Roll Groove Fittings, pg. 5-2; for 14–24"/350–600mm Cut Groove Systems Request Publication 07.01										

Ductile iron except those marked (sw) which are segmentally welded steel.

IMPORTANT NOTE:

Fittings size 26–48"/650–1050mm are available roll grooved for installation with Style 770 large diameter pipe couplings, Contact Victaulic for details.

Fittings

Reducing Tee

NO. 25 Grooved Branch
NO. 29T Threaded Branch
 (Ductile Iron#)

For Complete Information
 Request Publication **07.01**

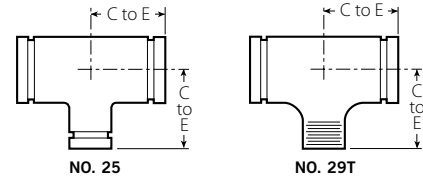

FITTINGS

Size			No. 25 Std.	No. 29T w/ Thd. Branch	Approx. Weight Each
Nominal Size Inches mm			C to E Inches mm	C to E Inches mm	Lbs. kg
1 25	×	1 25 × 3/4 20	+	+	1.0 0.5
1 1/4 32	×	1 1/4 32 × 1 25	+	+	1.3 0.6
1 1/2 40	×	1 1/2 40 × 3/4 20	+	+	1.5 0.7
			+	+	1.5 0.7
			+	+	1.7 0.8
2 50	×	2 50 × 3/4 20	3.25 83	3.25 83	2.5 1.1
			+	+	2.7 1.2
			+	+	1.8 0.8
			3.25 83	3.25 (sw) 83	3.0 1.4
2 1/2 65	×	2 1/2 65 × 3/4 20	+	+	3.9 1.8
			3.75 95	3.75 (sw) 95	3.8 1.7
			+	+	4.2 1.7
			3.75 95	3.75 95	3.9 1.8
			3.75 95	3.75 (sw) 95	4.5 2.0
			+	+	5.7 2.6
3 80	×	3 80 × 3/4 20	+	+	6.1 2.8
			4.25 108	4.25 108	8.0 3.6
			+	+	8.0 3.6
			4.25 108	4.25 (sw) 108	6.5 2.9
			4.25 108	4.25 (sw) 108	6.2 2.8
			4.25 108	4.25 (sw) 108	6.4 2.9
			+	+	8.0 3.6
4 100	×	4 100 × 3/4 20	+	+	7.8 3.5
			5.00 127	5.00 127	9.6 4.4
			+	+	9.6 4.4
			5.00 127	5.00 127	10.2 4.6
			5.00 127	5.00 127	11.2 5.1
			5.00 127	5.00 127	11.4 5.2
			5.00 127	5.00 127	11.6 5.3
			5.00 127	5.00 127	
			5.00 127	5.00 127	
			5.00 127	5.00 127	

Size			No. 25 Std.	No. 29T w/ Thd. Branch	Approx. Weight Each			
Nominal Size Inches mm			C to E Inches mm	C to E Inches mm	Lbs. kg			
5 125	×	5 125 × 1 25	+	+	14.0 6.4			
			+	+	14.3 6.5			
			2 50	5.50 (sw) 140	5.50 (sw) 140	14.5 6.6		
			2 1/2 65	5.50 140	5.50 (sw) 140	15.2 6.9		
			3 80	5.50 140	5.50 (sw) 140	16.6 7.5		
			4 100	5.50 140	5.50 (sw) 140	16.7 7.6		
			6 150	6 150	6 150	23.0 10.4		
6 150	×	6 150 × 1 1/2 40	+	+	24.0 10.9			
			2 50	6.50 165	6.50 165	21.6 9.8		
			2 1/2 65	6.50 165	6.50 165	21.4 11.7		
			3 80	6.50 165	6.50 165	26.5 12.0		
			4 100	6.50 165	6.50 165	25.0 11.3		
			5 125	6.50 165	6.50 165	23.2 10.5		
6 1/2 165.1	×	6 1/2 165.1 × 3 80	6.50 165	6.50 (sw) 165	24.0 10.9			
8 200	×	8 200 × 1 1/2 40	+	+	33.0 15.0			
			2 50	7.75 (sw) 197	7.75 (sw) 197	33.5 15.2		
			2 1/2 65	+	+	39.0 17.7		
			3 80	7.75 (sw) 197	7.75 (sw) 197	33.6 15.2		
			4 100	7.75 197	7.75 197	41.8 19.0		
			5 125	7.75 (sw) 197	7.75 (sw) 197	34.0 15.4		
			6 150	7.75 197	7.75 197	42.3 19.2		
			6 1/2 165.1	7.75 (sw) 197	7.75 (sw) 197	48.0 21.8		
			TABLE CONTINUED ON PG. 2-8					
			14 – 24 350 – 600			 See AGS Roll Groove Fittings, pg. 5-2; for 14–24"/350–600mm Cut Groove Systems Request Publication 07.01		

+ Contact Victaulic for details.

Ductile iron except those that are marked (sw), which are segmentally welded steel.

IMPORTANT NOTE:

No. 29T Threaded Outlet Reducing Tees are supplied NPT and are available with British Standard threads. For British Standard specify "BSP" clearly on order.

Fittings

Reducing Tee

NO. 25 Grooved Branch
NO. 29T Threaded Branch
 (Ductile Iron#)

For Complete Information
 Request Publication **07.01**

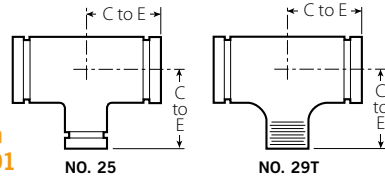

Standpipe Tee

NO. 27
 (Ductile iron)

For Complete Information
 Request Publication **07.01**

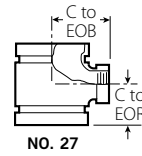

Size	No. 25 Std.	No. 29T w/ Thd. Branch	Approx. Weight Each																																				
Nominal Size Inches mm	C to E Inches mm	C to E Inches mm	Lbs. kg																																				
TABLE CONTINUED FROM PG. 2-7																																							
10 250	10 250	1 1/2 40	+	+	62.0 28.1																																		
						2 50	9.00 (sw) 229	9.00 (sw) 229	62.0 28.1																														
										2 1/2 65	+	+	62.4 28.3																										
														3 80	+	+	60.0 27.2																						
																		4 100	9.00 (sw) 229	9.00 (sw) 229	61.0 27.7																		
																						5 125	9.00 (sw) 229	9.00 (sw) 229	52.0 23.6														
																										6 150	9.00 (sw) 229	9.00 (sw) 229	59.0 26.8										
																														8 200	9.00 (sw) 229	9.00 (sw) 229	64.7 29.3						
																																		12 300	12 300	1 25	+	+	77.0 34.9
2 1/2 65	+	+	78.0 35.4																																				
				3 80	10.00 (sw) 254	10.00 (sw) 254	82.0 37.2																																
								4 100	10.00 (sw) 254	10.00 (sw) 254	80.0 36.3																												
												5 125	10.00 (sw) 254	10.00 (sw) 254	75.0 34.0																								
																6 150	10.00 (sw) 254	10.00 (sw) 254	75.0 34.0																				
																				8 200	10.00 (sw) 254	10.00 (sw) 254	80.0 36.3																
																								10 250	10.00 (sw) 254	10.00 (sw) 254	84.0 38.1												
																												14 - 24 350 - 600	 See AGS Roll Groove Fittings, pg. 5-2; for 14-24"/350-600mm Cut Groove Systems Request Publication 07.01										

+ Contact Victaulic for details.

Ductile iron except those that are marked (sw), which are segmentally welded steel.

IMPORTANT NOTE:

No. 29T Threaded Outlet Reducing Tees are supplied NPT and are available with British Standard threads. For British Standard specify "BSP" clearly on order.

Size	No. 27 Standpipe Tee		Approx. Weight Each
Nominal Size Inches mm	C to EOR Inches mm	C to EOB Inches mm	Lbs. kg
4 100	4 100	2 1/2 65	9.1 4.1
6 150	6 150	2 1/2 65	3.25 83
			5.13 130
			14.8 6.7

IMPORTANT NOTE:

Available with British Standard Pipe Threads, specify "BSP" clearly on order.

Bullhead Tee

NO. 21
 (Ductile Iron)

For Complete Information
 Request Publication **07.01**

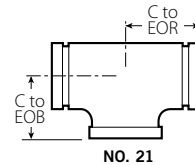

Size	No. 21 Bullhead Tee		Approx. Weight Each
Nominal Size Inches mm	C to EOR Inches mm	C to EOB Inches mm	Lbs. kg
5 125	5 125	8 200	28.7 13.0
6 150	6 150	8 200	7.75 197
			5.50 140
			6.50 165
			37.5 17.0

Bull Plug

NO. 61
 (Steel)

For Complete Information
 Request Publication **07.01**



Size	No. 61 Bull Plug		Approx. Weight Each
Nominal Size Inches mm	Actual Outside Diameter Inches mm	E to E Inches mm	Lbs. kg
2 50	2.375 60.3	4.00 102	2.5 1.1
2 1/2 65	2.875 73.0	5.00 127	3.0 1.4
3 80	3.500 88.9	6.00 152	4.5 2.0
4 100	4.500 114.3	7.00 178	7.5 3.4
5 125	5.563 141.3	8.00 203	12.0 5.4
6 150	6.625 168.3	10.00 254	17.0 7.7

IMPORTANT NOTES:

Steel dish caps available through 24"/600mm, contact Victaulic.

No. 61 Bull Plugs should be used in vacuum service with Style 72 or 750 couplings.

Fittings

45° Lateral

NO. 30

(Segmentally Welded Steel#)

For Complete Information
Request Publication **07.01**

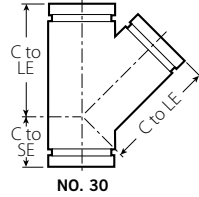

NO. 30

45° Reducing Lateral

NO. 30-R

(Segmentally Welded Steel)

For Complete Information
Request Publication **07.01**

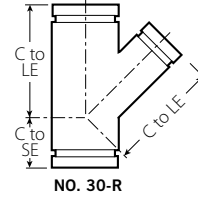

NO. 30-R

FITTINGS

Size		No. 30 45° Lateral		
Nominal Size Inches mm	Actual Outside Diameter Inches mm	C to LE Inches mm	C to SE Inches mm	Approx. Weight Each Lbs. kg
3/4 20	1.050 26.9	4.50 114	2.00 51	1.0 0.5
1 25	1.315 33.7	5.00 127	2.25 57	1.7 0.8
1 1/4 32	1.660 42.4	5.75 146	2.50 64	2.5 (d) 1.1
1 1/2 40	1.900 48.3	6.25 159	2.75 70	3.5 1.6
2 50	2.375 60.3	7.00 178	2.75 70	4.6 (d) 2.1
2 1/2 65	2.875 73.0	7.75 197	3.00 76	9.0 4.1
76.1 mm	3.000 76.1	8.50 216	3.25 83	11.0 5.0
3 80	3.500 88.9	8.50 216	3.25 83	11.7 (d) 5.4
3 1/2 90	4.000 101.6	10.00 254	3.50 89	17.8 8.1
4 100	4.500 114.3	10.50 267	3.75 95	22.2 (d) 10.1
5 125	5.563 141.3	12.50 318	4.00 102	21.8 9.9
6 150	6.625 168.3	14.00 356	4.50 114	43.6 19.8
165.1 mm	6.500 165.1	14.00 356	4.50 114	43.6 19.8
8 200	8.625 219.1	18.00 457	6.00 152	72.0 32.7
10 250	10.750 273.0	20.50 521	6.50 165	105.0 47.6
12 300	12.750 323.9	23.00 584	7.00 178	165.0 74.8
14 – 24 350 – 600	AGS [™]	See AGS Roll Groove Fittings, pg. 5-2; for 14–24"/350–600mm Cut Groove Systems Request Publication 07.01		

Segmentally welded steel except those marked (d) which are ductile iron.

Size		No. 30-R 45° Reducing Lateral		
Nominal Size Inches mm		C to LE Inches mm	C to SE Inches mm	Approx. Weight Each Lbs. kg
3 80	3 80	2 50	8.50 216	9.8 4.4
		2 1/2 65	8.50 216	9.8 4.4
4 100	4 100	2 50	10.50 267	10.0 4.5
		2 1/2 65	10.50 267	10.0 4.5
		3 80	10.50 267	18.3 8.3
5 125	5 125	2 50	12.50 318	24.0 10.9
		3 80	12.50 318	27.0 12.2
		4 100	12.50 318	26.5 12.0
6 150	6 150	3 80	14.00 356	37.0 16.8
		4 100	14.00 356	36.0 16.3
		5 125	14.00 356	44.7 20.3
8 200	8 200	4 100	18.00 457	62.0 28.1
		5 125	18.00 457	75.5 34.2
		6 150	18.00 457	82.0 37.2
10 250	10 250	4 100	20.50 521	104.8 47.5
		5 125	20.50 521	99.0 44.9
		6 150	20.50 521	105.8 48.0
		8 200	20.50 521	118.0 53.5
12 300	12 300	5 125	23.00 584	122.0 55.3
		6 150	23.00 584	137.0 62.1
		8 200	23.00 584	147.0 66.7
		10 250	23.00 584	167.0 75.8
14 – 24 350 – 600	AGS [™]	See AGS Roll Groove Fittings, pg. 5-2; for 14–24"/350–600mm Cut Groove Systems Request Publication 07.01		

Fittings

Tee Wye

NO. 32
(Segmentally Welded Steel)

For Complete Information
Request Publication **07.01**

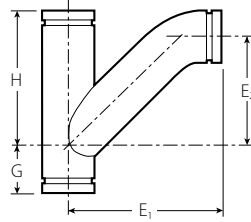

NO. 32

Size	No. 32 Tee Wye					Approx. Wgt. Each Lbs. kg
	Nominal Size Inches mm	G Inches mm	H Inches mm	E ₁ Inches mm	E ₂ Inches mm	
2 50 × 2 50 × 2 50	2.75 70	7.00 178	9.00 229	4.63 118	6.4 2.9	
2½ 65 × 2½ 65 × 2½ 65	3.00 76	7.75 197	10.50 267	5.75 146	11.5 5.2	
3 80 × 3 80 × 3 80	3.25 83	8.50 216	11.50 292	6.50 165	14.3 6.5	
3½ 90 × 3½ 90 × 3½ 90	3.25 89	10.00 254	13.00 330	7.75 197	22.9 10.4	
4 100 × 4 100 × 4 100	3.75 95	10.50 267	13.63 346	8.13 207	26.0 11.8	
5 125 × 5 125 × 5 125	4.00 102	12.50 318	16.13 410	10.00 254	48.0 21.8	
6 150 × 6 150 × 6 150	4.50 114	14.00 356	18.25 464	11.50 292	60.5 27.4	
8 200 × 8 200 × 8 200	6.00 152	18.00 457	23.25 591	15.25 387	127.1 57.7	
10 250 × 10 250 × 10 250	6.50 165	20.50 521	27.25 692	18.00 457	190.0 86.2	
12 300 × 12 300 × 12 300	7.00 178	23.00 584	31.00 787	20.50 521	240.0 108.9	
14 – 24 350 – 600	 See AGS Roll Groove Fittings, pg. 5-2; for 14 – 24"/350 – 600 mm Cut Groove Systems Request Publication 07.01					

Reducing Tee Wye

NO. 32-R
(Segmentally Welded Steel)

For Complete Information
Request Publication **07.01**

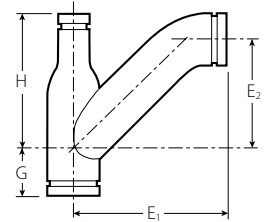

NO. 32-R

Size	No. 32-R Reducing Tee Wye					Approx. Wgt. Each Lbs. kg
	Nominal Size Inches mm	G Inches mm	H Inches mm	E ₁ Inches mm	E ₂ Inches mm	
4 100 × 3 80 × 3 80	3 80	3.50 89	9.50 241	10.75 273	5.75 146	16.0 7.3
	3 80	3.75 95	10.50 267	13.63 346	8.13 206	16.0 7.3
4 100 × 4 100 × 3 80	3 80	3.75 95	10.50 267	12.88 327	7.88 200	23.0 10.4
	3 80	1.25 32	9.75 248	11.50 292	7.63 194	25.0 11.3
5 125 × 3 80 × 3 80	3 80	4.00 102	12.50 318	16.13 410	11.13 283	43.4 19.5
	3 80	1.88 48	9.13 232	11.88 302	6.88 175	21.0 9.5
5 125 × 4 100 × 3 80	3 80	1.88 48	9.13 232	12.75 324	7.25 184	25.0 11.3
	3 80	4.00 102	12.50 318	14.25 362	9.25 235	29.0 13.2
5 125 × 5 125 × 4 100	4 100	4.00 102	12.50 318	15.13 384	9.63 245	36.7 16.6
	4 100	4.50 114	14.00 356	18.25 464	11.50 292	61.0 27.7
6 150 × 4 100 × 6 150	6 150	1.25 32	10.75 273	13.00 330	8.00 203	27.0 12.2
	4 100	1.25 32	10.75 273	13.88 352	8.38 213	31.0 14.1
6 150 × 6 150 × 3 80	3 80	4.50 114	14.00 356	15.31 389	10.31 262	37.3 16.9
	4 100	4.50 114	14.00 356	16.25 413	10.75 273	46.3 21.0
	5 125	4.50 114	14.00 356	17.25 438	11.13 283	55.0 24.9
8 200 × 6 150 × 4 100	4 100	1.00 25	12.00 304	14.75 375	9.25 235	45.0 20.4
	4 100	6.00 152	18.00 457	23.25 591	15.25 387	112.0 50.8
8 200 × 8 200 × 3 80	3 80	6.00 152	18.00 457	18.19 462	13.19 335	76.0 34.5
	4 100	6.00 152	18.00 457	19.00 483	13.50 343	76.4 34.7
	5 125	6.00 152	18.00 457	20.00 508	13.88 352	85.6 38.8
	6 150	6.00 152	18.00 457	21.13 537	14.38 365	112.0 50.8
	6 150	6.50 165	20.50 521	21.88 556	15.75 400	115.0 52.2
10 250 × 10 250 × 3 80	3 80	6.50 165	20.50 521	19.88 505	14.88 378	96.0 43.5
	4 100	6.50 165	20.50 521	20.75 527	15.25 387	97.4 44.2
	5 125	6.50 165	20.50 521	21.88 556	15.75 400	115.0 52.2
	6 150	6.50 165	20.50 521	22.88 581	16.13 410	133.1 60.4
8 200	6.50 165	20.50 521	27.25 692	19.25 489	156.0 70.8	

Fittings

Adapter Nipple

- NO. 40** Grv. x Thd.
- NO. 42** Grv. x Bev.
- NO. 43** Grv. x Grv.
(Steel)

For Complete Information Request Publication **07.01**

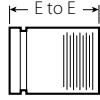

NO. 40#

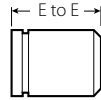

NO. 42

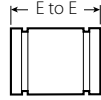

NO. 43

Size		No. 40, 42, 43 Adapter Nipple (sw)	
Nominal Size Inches mm	Actual Outside Diameter Inches mm	E to E Inches mm	Approx. Weight Each Lbs. kg
3/4	1.050	3.00	0.3
20	26.9	76	0.1
1	1.315	3.00	0.4
25	33.7	76	0.2
1 1/4	1.660	4.00	0.8
32	42.4	102	0.4
1 1/2	1.900	4.00	0.9
40	48.3	102	0.4
2	2.375	4.00	1.2
50	60.3	102	0.5
2 1/2	2.875	4.00	1.9
65	73.0	102	0.9
3	3.500	4.00	2.5
80	88.9	102	1.1
3 1/2	4.000	4.00	2.1
90	101.6	102	0.9
4	4.500	6.00	5.5
100	114.3	152	2.5
5	5.563	6.00	7.4
125	141.3	152	3.4
6	6.625	6.00	9.5
150	168.3	152	4.3
8	8.625	6.00	14.2
200	219.1	152	6.4
10	10.750	8.00	27.0
250	273.0	203	12.2
12	12.750	8.00	33.0
300	323.9	203	15.0
14 – 24 350 – 600	See AGS Roll Groove Fittings, pg. 5-2; for 14–24"/350–600mm Cut Groove Systems Request Publication 07.01		

Available with British Standard Pipe Threads, specify "BSP" clearly on order.

IMPORTANT NOTES:

For pump package nipples with 1 1/2"/40mm hole cut to receive Style 923 Vic-Let or Style 924 Vic-O-Well request special No. 40, 42 or 43 nipples and specify No. 40-H, 42-H or 43-H on order. NOTE: 4 – 12"/100 – 300mm diameter – 8"/200mm minimum length required.

Cap

- NO. 60**
(Ductile Iron)

For Complete Information Request Publication **07.01**



NO. 60

Size		No. 60 Cap	
Nominal Size Inches mm	Actual Outside Diameter Inches mm	T Thickness Inches mm	Approx. Weight Each Lbs. kg
3/4	1.050	0.88	0.2
20	26.9	22	0.1
1	1.315	0.88	0.3
25	33.7	22	0.1
1 1/4	1.660	0.88	0.3
32	42.4	22	0.1
1 1/2	1.900	0.88	0.5
40	48.3	22	0.2
2	2.375	0.88	0.6
50	60.3	22	0.3
2 1/2	2.875	0.88	1.0
65	73.0	22	0.5
76.1 mm	3.000	0.88	1.2
	76.1	22	0.5
3	3.500	0.88	1.2
80	88.9	22	0.5
3 1/2	4.000	0.88	2.5
90	101.6	22	1.1
4	4.500	1.00	2.5
100	114.3	25	1.1
108.0 mm	4.250	1.00	2.3
	108.0	25	1.0
4 1/2	5.000	1.00	2.5
120	127.0	25	1.1
5	5.563	1.00	4.6
125	141.3	25	2.1
133.0 mm	5.250	1.00	4.5
	133.0	25	2.0
139.7 mm	5.500	1.00	4.5
	139.7	25	2.0
6	6.625	1.00	6.1
150	168.3	25	2.8
159.0 mm	6.250	1.00	6.8
	159.0	25	3.1
165.1 mm	6.500	1.00	7.3
	165.1	25	3.3
8	8.625	1.19	13.1
200	219.1	30	5.9
10	10.750	1.25	21.0
250	273.0	32	9.5
12	12.750	1.25	35.6
300	323.9	32	16.2
14 – 24 350 – 600	See AGS Roll Groove Fittings, pg. 5-2; for 14–24"/350–600mm Cut Groove Systems Request Publication 07.01		

IMPORTANT NOTES:

Steel dish caps available through 24"/600mm. No. 60 cap available tapped. Contact Victaulic for details.

No. 60 cap is not suitable for use in vacuum service with Style 72 or 750 couplings. No. 61 bull plugs should be used, see pg. 2-8.

Fittings

Flanged Adapter Nipple

NO. 41 ANSI Class 125 (Cast Iron)

NO. 45F ANSI Class 150 Flat Face (Steel)

NO. 45R ANSI Class 150 Raised Face (Steel)

NO. 46F ANSI Class 300 Flat Face (Steel)

NO. 46R ANSI Class 300 Raised Face (Steel)

For Complete Information
Request Publication **07.01**

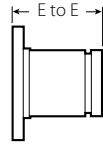

NO. 41

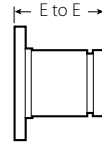

NO. 45F

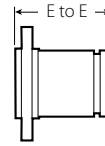

NO. 45R

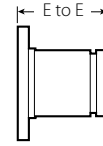

NO. 46F

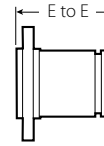

NO. 46R

Size		No. 41 ANSI 125 Flange Adapter Nipple		No. 45F and No. 45R ANSI 150 Flange Adapter Nipple		No. 46F and No. 46R ANSI 300 Flange Adapter Nipple	
Nominal Size Inches mm	Actual Outside Diameter Inches mm	E to E Inches mm	Approx. Weight Each Lbs. kg	E to E Inches mm	Approx. Weight Each Lbs. kg	E to E Inches mm	Approx. Weight Each Lbs. kg
3/4 20	1.050 26.9	3.00 76	2.3 1.0	3.00 76	2.3 1.0	3.00 76	3.3 1.5
1 25	1.315 33.7	3.00 76	2.5 1.1	3.00 76	2.7 1.2	3.00 76	3.9 1.8
1 1/4 32	1.660 42.4	4.00 102	3.0 1.4	4.00 102	3.3 1.5	4.00 102	4.8 2.2
1 1/2 40	1.900 48.3	4.00 102	3.5 1.6	4.00 102	3.9 1.8	4.00 102	6.9 3.1
2 50	2.375 60.3	4.00 102	5.5 2.5	4.00 102	6.2 2.8	4.00 102	8.2 3.7
2 1/2 65	2.875 73.0	4.00 102	8.0 3.6	4.00 102	9.9 4.5	4.00 102	11.9 5.4
3 80	3.500 88.9	4.00 102	9.5 4.3	4.00 102	11.4 5.2	4.00 102	16.5 7.5
3 1/2 90	4.000 101.6	4.00 102	12.0 5.4	4.00 102	15.1 6.8	4.00 102	20.1 9.1
4 100	4.500 114.3	6.00 152	16.7 7.6	6.00 152	18.4 8.3	6.00 152	27.4 12.4
5 125	5.563 141.3	6.00 152	21.5 9.8	6.00 152	21.3 9.7	6.00 152	35.3 16.0
6 150	6.625 168.3	6.00 152	26.5 12.0	6.00 152	27.5 12.5	6.00 152	47.5 21.5
8 200	8.625 219.1	6.00 152	39.0 17.7	6.00 152	41.3 18.8	6.00 152	70.3 31.9
10 250	10.750 273.0	8.00 203	57.0 25.9	8.00 203	59.8 27.1	8.00 203	100.8 45.7
12 300	12.750 323.9	8.00 203	41.0 18.6	8.00 203	88.2 40.0	8.00 203	146.2 66.3
14 – 24 350 – 600	AGS ™ See AGS Roll Groove Fittings, pg. 5-2; for 14–24"/350–600mm Cut Groove Systems Request Publication 07.01						

IMPORTANT NOTES:

Flanged adapter nipples are supplied with standard rolled grooves. Standard cut grooves or machining for rubber lining are optionally available. Contact Victaulic for details.

Fittings

Swaged Nipple

NO. 53 Grv. × Grv.

NO. 54 Grv. × Thd.

NO. 55 Thd. × Grv.

(Steel)

For Complete Information
Request Publication **07.01**

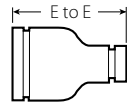

NO. 53

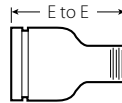

NO. 54

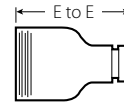

NO. 55

Size		No. 53, 54 and 55 Swaged Nipples	
Nominal Size Inches mm		E to E Inches mm	Approx. Weight Each Lbs. kg
2 50	× 1 25	6.50 165	2.0 0.9
		1 1/4 32	2.0 0.9
		1 1/2 40	2.0 0.9
2 1/2 65	× 1 25	7.00 178	3.0 1.4
		1 1/4 32	3.0 1.4
		1 1/2 40	3.0 1.4
		2 50	3.0 1.4
3 80	× 1 25	8.00 203	4.5 2.0
		1 1/4 32	4.5 2.0
		1 1/2 40	4.4 2.0
		2 50	4.5 2.0
		2 1/2 65	4.5 2.0
3 1/2 90	× 3 80	8.00 203	6.8 3.1
4 100	× 1 25	9.00 229	7.5 3.4
		1 1/4 32	7.5 3.4
		1 1/2 40	7.5 3.4
		2 50	7.5 3.4

Size		No. 53, 54 and 55 Swaged Nipples	
Nominal Size Inches mm		E to E Inches mm	Approx. Weight Each Lbs. kg
4 100	× 2 1/2 65	9.00 229	7.5 3.4
		3 80	7.5 3.4
		3 1/2 90	7.5 3.4
5 125	× 2 50	11.00 279	11.5 5.2
		3 80	11.3 5.1
		4 100	11.5 5.2
6 150	× 1 25	12.00 305	17.0 7.7
		1 1/4 32	17.0 7.7
		1 1/2 40	17.2 7.8
		2 50	17.4 7.9
		2 1/2 65	17.4 7.9
		3 80	17.4 7.9
		3 1/2 90	17.4 7.9
		4 100	17.5 7.9
		4 1/2 120	17.5 7.9
8 200	× 6 150	+	20.0 9.1

+ Contact Victaulic for details.

Fittings

Female Threaded Adapter

NO. 80

(Ductile Iron#)

For Complete Information
Request Publication **07.01**

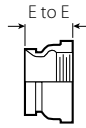

NO. 80

Size		No. 80 Female Threaded Adapter	
Nominal Size Inches mm	Actual Outside Diameter Inches mm	E to E Inches mm	Approx. Weight Each Lbs. kg
¾ 20	1.050 26.9	2.00 51	1.0 0.5
1 25	1.315 33.7	2.06 52	1.0 0.5
1¼ 32	1.660 42.4	2.31 (sw) 59	1.5 0.7
1½ 40	1.900 48.3	2.31 (sw) 59	1.5 0.7
2 50	2.375 60.3	2.50 64	1.4 0.6
2½ 65	2.875 73.0	2.75 70	1.5 0.7
3 80	3.500 88.9	2.75 70	2.9 1.3
4 100	4.500 114.3	3.25 83	4.5 2.0

Ductile iron except those marked (sw) which are segmentally welded steel.

IMPORTANT NOTE:

Available with British Standard Pipe threads, specify "BSP" clearly on order.

Hose Nipple

NO. 48

(Segmentally Welded Steel)

For Complete Information
Request Publication **07.01**

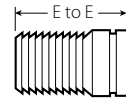

NO. 48

Size		No. 48 Hose Nipple	
Nominal Size Inches mm	Actual Outside Diameter Inches mm	E to E Inches mm	Approx. Weight Each Lbs. kg
¾ 20	1.050 26.9	3.12 79	0.3 0.1
1 25	1.315 33.7	3.38 86	0.4 0.2
1¼ 32	1.660 42.4	3.88 98	0.6 0.3
1½ 40	1.900 48.3	3.88 98	0.8 0.4
2 50	2.375 60.3	4.50 114	1.1 0.5
2½ 65	2.875 73.0	5.38 137	2.0 0.9
3 80	3.500 88.9	5.75 146	3.2 1.5
4 100	4.500 114.3	7.00 178	4.9 2.2
5 125	5.563 141.3	8.75 222	8.0 3.6
6 150	6.625 168.3	10.12 257	14.3 6.5
8 200	8.625 219.1	11.88 302	24.7 11.2
10 250	10.750 273.0	12.50 318	40.1 18.2
12 300	12.750 323.9	14.50 368	62.0 28.1

Fittings

Concentric/Eccentric Reducer

NO. 50 Concentric

NO. 51 Eccentric
(Ductile Iron#)

For Complete Information
Request Publication **07.01**

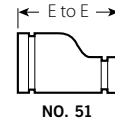
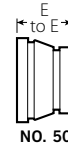

FITTINGS

Size	No. 50 Concentric Reducer		No. 51 Eccentric Reducer	
	Nominal Size Inches mm	E to E Inches mm	E to E Inches mm	Approx. Weight Each Lbs. kg
1 1/4 × 3/4 32 20	+	1.9 0.9	—	—
	1 25	+	1.9 0.9	—
1 1/2 × 3/4 40 20	+	1.4 0.6	—	—
	1 25	2.50* 64	0.8 0.4	8.50(sw) 216
	1 1/4 32	2.50* 64	1.0 0.5	—
2 × 3/4 50 20	2.50* 64	0.9 0.3	9.00(sw) 229	2.0 0.9
	1 25	2.50* 64	0.7 0.3	9.00(sw) 229
	1 1/4 32	2.50* 64	1.2 0.5	9.00(sw) 229
	1 1/2 40	2.50* 64	1.0 0.5	3.50 89
2 1/2 † × 3/4 65 20	+	1.3 0.6	+	3.3 1.5
	1 25	2.50 64	3.6 1.5	9.50(sw) 241
	1 1/4 32	2.50*(sw) 64	3.3 1.5	3.50 89
	1 1/2 40	2.50* 64	3.6 1.6	9.50(sw) 241
	2 50	2.50 64	3.9 1.8	9.50(sw) 241
3 × 3/4 80 20	+	1.5 0.7	+	4.5 2.0
	1 25	2.50* 64	1.3 0.6	9.50(sw) 241
	1 1/4 32	2.50 64	3.0 1.4	+
	1 1/2 40	2.50* 64	5.1 2.3	9.50(sw) 241
	2 50	2.50* 64	1.6 0.7	3.50 89
	2 1/2 65	2.50* 64	1.8 0.8	3.50 89
	76.1	2.50 64	2.1 1.0	—
3 1/2 × 3 90 80	2.50 64	2.0 0.9	9.50(sw) 241	7.0 3.2
	4 × 1 100 25	3.00* 76	3.0 1.4	13.00(sw) 330
1 1/4 × 1 32 25	+	4.6 2.1	—	—
	1 1/2 40	3.00 76	6.9 3.1	10.00(sw) 254
	2 50	3.00* 76	2.4 1.1	4.00 102
	2 1/2 65	3.00* 76	2.7 1.2	4.00 102
	3 80	3.00* 76	3.2 1.4	4.00 102
	3 1/2 90	3.00 76	2.9 1.3	10.00(sw) 254
	3.6	3.00 76	1.3	3.6

Size	No. 50 Concentric Reducer		No. 51 Eccentric Reducer		
	Nominal Size Inches mm	E to E Inches mm	E to E Inches mm	Approx. Weight Each Lbs. kg	
5 × 2 125 50	11.00(sw) 279	9.0 4.1	11.00(sw) 279	5.2 2.4	
	2 1/2 65	4.00 102	11.00(sw) 279	10.8 4.9	
	3 80	4.00 102	11.00(sw) 279	11.1 5.0	
	4 100	3.50 89	5.00 127	12.0 5.4	
6 † × 1 150 25	4.00* 102	5.0 2.3	11.50(sw) 292	14.5 6.6	
	1 1/2 40	+	+	+	
	2 50	4.00* 102	6.6 3.0	11.50(sw) 292	
	2 1/2 65	4.00* 102	6.4 2.9	11.50(sw) 292	
	3 80	4.00* 102	6.4 2.9	5.50 140	
	4 100	4.00 102	6.5 2.9	5.50 140	
	5 125	4.00 102	6.4 2.9	5.50 140	
	8 × 2 1/2 200 65	16.00 406	7.9 3.6	12.00(sw) 305	26.1 11.8
	3 80	5.00 127	9.3 4.2	12.00(sw) 305	22.0 10.0
	4 100	5.00 127	10.4 4.8	12.00(sw) 305	23.0 10.4
10 × 4 250 100	5 125	5.00 127	11.6 5.2	12.00(sw) 305	
	6 150	5.00 127	11.9 5.4	6.00 152	
	4 100	6.00 152	19.7 8.9	13.00(sw) 330	
	5 125	+	34.3 15.6	+	
	6 150	6.00 152	20.0 9.1	13.00(sw) 330	
	8 200	6.00 152	22.0 10.0	7.00 178	
12 × 4 300 100	4 100	+	44.0 20.0	14.00(sw) 356	
	6 150	7.00 178	24.6 11.2	14.00(sw) 356	
	8 200	7.00 178	52.0 23.6	14.00(sw) 356	
	10 250	7.00 178	39.0 17.7	14.00(sw) 356	
14 – 24 350 – 600	AGS See AGS Roll Groove Fittings, pg. 5-2; for 14–24"/350–600mm Cut Groove Systems Request Publication 07.01				

+ Contact Victaulic for details.

* Available with male threaded small end No. 52.

Ductile Iron except those marked (sw) which are segmentally welded steel.

† Available in 76.1 mm and 165.1 mm sizes to these dimensions.

IMPORTANT NOTE:

Steel eccentric reducers available through 30"/750mm, contact Victaulic.

Fittings

Small Threaded Reducer

NO. 52

NO. 52F (BSPT)

(Ductile Iron#)

For Complete Information
Request Publication **07.01**



NO. 52

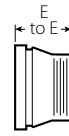

NO. 52F

Size	No. 52 Small Threaded Reducer		No. 52F Small Threaded Reducer (BSPT)		
	Nominal Size Inches mm	E to E Inches mm	Approx. Weight Each Lbs. kg	E to E Inches mm	Approx. Weight Each Lbs. kg
1½ 40 ×	1 25	2.50 64	0.8 0.4	—	—
	1¼ 32	2.50 64	0.9 0.4	—	—
2 50 ×	¾ 20	2.50 64	0.9 0.4	—	—
	1 25	2.50 64	0.7 0.3	—	—
	1¼ 32	2.50 64	1.2 0.5	—	—
	1½ 40	2.50 64	1.0 0.5	—	—
2½ 65 ×	1 25	1.0 0.5	1.0 0.5	—	—
	1¼ 32	2.50(sw) 64	1.2 0.5	—	—
	1½ 40	2.50(sw) 64	1.3 0.6	—	—
	2 50	2.50 64	1.4 0.6	—	—
76.1† ×	48.3	63.5	0.8	63.5	0.8
	60.0	—	—	63.5	0.9
3 80 ×	¾ 20	+(sw)	1.5 0.7	—	—
	1 25	2.50 64	1.3 0.6	—	—
	1¼ 32	2.50 64	1.4 0.6	—	—
	1½ 40	2.50(sw) 64	1.5 0.7	—	—
	2 50	2.50 64	1.5 0.7	—	—
	2½ 65	2.50 64	2.4 1.1	—	—
88.9† ×	42.4	63.5	0.9	63.5	0.8
	48.3	63.5	0.9	63.5	0.9
	60.0	—	—	63.5	0.9
4 100 ×	1 25	3.00 76	2.3 1.0	—	—
	1½ 40	3.00 76	2.5 1.1	—	—
	2 50	3.00 76	2.6 1.2	—	—
	2½ 65	3.00 76	2.6 1.2	—	—
	3 80	3.00 76	2.5 1.1	—	—

Size	No. 52 Small Threaded Reducer		No. 52F Small Threaded Reducer (BSPT)		
	Nominal Size Inches mm	E to E Inches mm	Approx. Weight Each Lbs. kg	E to E Inches mm	Approx. Weight Each Lbs. kg
108.0† ×	42.4	76.2	1.3	76.2	1.3
	48.3	76.2	1.3	76.2	1.4
	60.0	—	—	76.2	1.4
114.3† ×	42.4	76.2	1.3	76.2	1.3
	48.3	76.2	1.3	76.2	1.3
	60.0	—	—	76.2	1.4
5 125 ×	4 100	+(sw)	4.5 2.0	—	—
133.0† ×	60.0	—	—	114.3	2.2
139.0† ×	60.0	—	—	114.3	2.3
6 150 ×	1 25	4.00 102	5.5 2.5	—	—
	2 50	4.00 102	5.7 2.6	—	—
	2½ 65	4.00 102	5.8 2.6	—	—
	3 80	4.00 102	5.8 2.6	—	—
	4 100	+(sw)	6.5 2.9	—	—
159.0† ×	5 125	+(sw)	17.5 7.9	—	—
	42.4	114.3	2.2	114.3	2.5
	48.3	114.3	2.2	114.3	2.5
165.1† ×	60.0	—	—	114.3	2.6
	42.4	101.6	2.4	101.6	2.9
	48.3	101.6	2.6	101.6	3.0
8 200 ×	60.0	—	—	101.6	3.0
	2 50	+(sw)	1.5 0.7	—	—

+ Contact Victaulic for details.

Ductile iron except those marked (sw) which are segmentally welded steel.

† Available in metric sizes only.

Valves

Designed for a wide variety of applications, Victaulic valves are engineered and manufactured for dependable, trouble-free performance, superior flow control and durable, long-lasting reliability.

Victaulic offers a full complement of butterfly, check, ball, triple service, circuit balancing and plug valves in a variety of wear-resistant materials and coatings to satisfy your specific piping application requirements.

Advanced Groove System **AGS™**



For 14–24"/350–600 mm piping systems
Victaulic offers Advanced Groove System (AGS) butterfly and check valves, see pg. 5-1.



Butterfly Valves

Victaulic butterfly valves deliver excellent performance characteristics, including low torque, high flow, dead-end service, and bi-directional flow capability to full rated pressure. Available in sizes from 1½–24"/40–600 mm, our butterfly valves are offered in a variety of housing, disc and seat seal configurations, including bodies constructed of durable ductile iron, stainless steel, and bronze with EPDM, nitrile, or fluoroelastomer seat materials.

All butterfly valves are available with manual handles, gear operators or automated configurations.



Check Valves

Vic-Check valves are available in several configurations. A spring-assisted, single disc design is used on Series 716 check valves, which can be installed in the horizontal or vertical position. The Series 779 Venturi check valve allows for calibrated flow measurement and easily connects to Vic-300 MasterSeal butterfly valves or Series 377 Vic-Plug valves for triple service assemblies. Also available are swing check valves (ductile or stainless) for oil field applications.



Ball Valves

The Vic-Ball® valve is a high-pressure, standard-port ball valve with grooved ends. Its internal design has been streamlined to provide excellent flow characteristics, and comes available in ductile iron and stainless steel versions. A three-port diverter ball for redirecting flow 90° left or right is available for carbon steel or stainless steel piping systems. Vic-Ball valves are sized 1½–6"/40–150 mm depending on body construction type. A ¼–2"/10–50 mm threaded brass ball valve is also available for a variety of services.



Circuit Balancing Valves

TA circuit balancing valves, provided by Victaulic, offer a reliable, efficient and cost effective method of balancing and measuring all system flow rates. Full throttling range is achieved by 4, 8, 12, or 16 full turns of the handwheel, enabling a precise setting. The result is a high degree of accurate adjustment and precise system balancing.

TA circuit balancing valves, provided by Victaulic, are offered in a variety of end configurations and sizes for a variety of heating and cooling applications. A line of automatic flow control valves and accessories is also available.

Valves

Valve Application Guide

Valve Type	Building Services	Industrial	Water and Wastewater	Mining	Oil Field	Plumbing
BUTTERFLY VALVES	●	●	●	●	●	●
CHECK VALVES	●	●	●	●	●	
BALL VALVES	●	●	●	●	●	●
CIRCUIT BALANCING VALVES	●	●				●
PLUG VALVES	●		●			
TRIPLE SERVICE VALVES	●	●				



Plug Valves

Made of ductile iron in a variety of coatings, Series 365 Vic-Plug™ valves are the lightest, most easily installed eccentric plug valves on the market today. The round port design with welded-in nickel seat provides reliable, long-lasting service. Available in 3–12"/80–300 mm, 175 psi/1200 kPa, and 14–18"/350–450 mm, 150 psi/1035 kPa.

Series 377 Vic-Plug balancing valves are the only eccentric grooved end plug valves on the market made specifically for throttling services, and are available in 3–6"/80–150 mm sizes for systems pressure rated up to 175 psi/1200 kPa.



Triple Service Valves

The Victaulic tri-service valve assembly consists (shipped as individual components) of a standard Victaulic butterfly or Vic-Plug valve and a check valve. This combination provides shut-off, throttling with positive mechanical memory and non-slam check service in one unit.

The Series 779 check valve features accurate flow measurement capabilities plus spring assisted closing in a high flow design. The venturi-like inlet is drilled, tapped and plugged, ready to receive the flow measuring taps (included).

BUTTERFLY VALVES

- 3-3 Vic-300 MasterSeal®
- 3-6 Series 700
- 8-13 Series 763 Stainless Steel
- 11-9 Series 608 Copper

CHECK VALVES

- 3-7 Series 716
- 3-8 Series 779
- 3-9 Series 712
- 3-9 Series 713
- 13-17 Series 317

PLUG VALVES

- 3-10 Series 377
- 13-15 Series 365

BALL VALVES

- 3-11 Series 721
- 3-11 Series 722
- 3-12 Series 726

CIRCUIT BALANCING

- 3-15 TA Series 786
- 3-15 TA Series 787
- 3-16 TA Series 788
- 3-16 TA Series 789
- 3-17 Series 78U
- 3-17 Series 78Y
- 3-18 TA Series 793
- 3-18 TA Series 794
- 3-19 TA Accessories

TRIPLE SERVICE VALVES

- 3-5 Butterfly/Check Combo
- 3-5 Plug/Check Combo

PRODUCTS

- 1-1 Couplings
- 2-1 Fittings
- 3-1 Valves**
- 4-1 Accessories
- 5-1 Advanced Groove System
- 6-1 Hole Cut Piping System
- 7-1 Plain End Piping System
- 8-1 Grooved System for Stainless Steel Pipe
- 9-1 Pressfit System for Stainless Steel Pipe
- 10-1 Plain End Piping System for HDPE Pipe
- 11-1 Grooved Copper
- 12-1 PermaLynx System for Copper Tube
- 13-1 Grooved AWWA Ductile Iron Pipe
- 14-1 Victaulic Depend-O-Lok® System
- 15-1 Aquamine Reusable PVC Products
- 16-1 Gaskets
- 17-1 Pipe Preparation Tools
- 18-1 Product Index
- 19-1 Piping Software

Valves – Butterfly Valves

Vic-300® MasterSeal™ Butterfly Valve

For Complete Information
Request Publication **08.20**

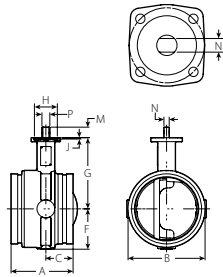

**BARE VALVE
TYPICAL 2-
12"/50-300 mm SIZES**

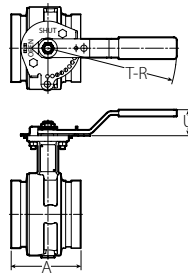

**VALVE WITH 10-POSITION
HANDLE TYPICAL
2-6"/50-150 mm SIZES**

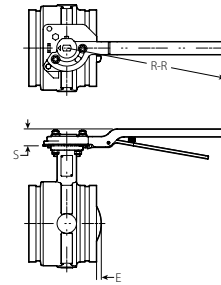

**VALVE WITH LEVER LOCK
AND MEMORY STOP TYPICAL
FOR 8"/200 mm SIZES ONLY**

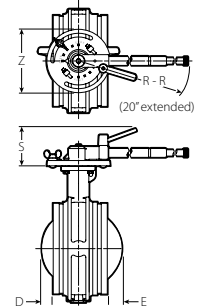

**VALVE WITH LEVER LOCK
AND MEMORY STOP TYPICAL
10-12"/250-300 mm SIZES**

Size @		Dimensions																	Approx. Weight Each	
Nominal Size Inches mm	Actual Outside Dia. Inches mm	A Inches mm	B Inches mm	C Inches mm	D Inches mm	E Inches mm	F Inches mm	G Inches mm	H Inches mm	J Inches mm	M Inches mm	N Inches mm	P Inches mm	R-R Inches mm	S Inches mm	T-R Inches mm	U Inches mm	Z Inches mm	Bare Lbs. kg	Lever Lbs. kg
2 50	2.375 60.3	3.21 81.5	3.25 82.6	1.44 36.6	—	—	1.81 46.0	3.81 96.8	2.17 55.2	0.13 3.3	0.88 22.4	0.32 8.0	0.43 11.0	—	—	7.10 180.3	1.67 42.4	—	3.5 1.6	6.0 2.7
2½ 65	2.875 73.0	3.77 95.8	4.00 101.6	1.77 45.0	—	—	2.10 53.3	4.25 108.0	2.17 55.2	0.13 3.3	0.88 22.4	0.32 8.0	0.43 11.0	—	—	7.10 180.3	1.67 42.4	—	5.0 2.3	7.5 3.4
76.1 mm	3.000 76.1	3.77 95.8	4.00 101.6	1.77 45.0	—	—	2.10 53.3	4.25 108.0	2.17 55.2	0.13 3.3	0.88 22.4	0.32 8.0	0.43 11.0	—	—	7.10 180.3	1.67 42.4	—	5.0 2.3	7.5 3.4
3 80	3.500 88.9	3.77 95.8	4.50 114.3	1.77 45.0	—	—	2.35 59.7	4.50 114.3	2.17 55.2	0.13 3.3	0.88 22.4	0.32 8.0	0.43 11.0	—	—	7.10 180.3	1.67 42.4	—	6.0 2.7	8.5 3.9
4 100	4.500 114.3	4.63 117.6	5.50 139.7	2.18 55.4	—	—	2.88 73.2	5.25 133.4	2.17 55.2	0.13 3.3	0.89 22.6	0.43 11.0	0.59 15.0	—	—	8.60 218.4	1.74 44.2	—	9.3 4.2	11.8 5.4
108.0mm †	4.250 108.0	4.63 117.6	5.50 139.7	2.18 55.4	—	—	2.88 73.2	5.25 133.4	2.17 55.2	0.13 3.3	0.89 22.6	0.43 11.0	0.59 15.0	—	—	8.60 218.4	1.74 44.2	—	9.3 4.2	11.8 5.4
5 125	5.563 141.3	5.88 149.4	6.30 160.0	2.18 55.4	—	—	3.34 84.8	6.25 158.8	2.17 55.2	0.13 3.3	1.12 28.5	0.50 12.7	0.75 19.1	—	—	12.10 307.3	1.74 44.2	—	16.8 7.6	20.0 9.1
133.0mm †	5.250 133.0	5.88 149.4	6.30 160.0	2.18 55.4	—	—	3.34 84.8	6.25 158.8	2.17 55.2	0.13 3.3	1.12 28.5	0.50 12.7	0.75 19.1	—	—	12.10 307.3	1.74 44.2	—	16.8 7.6	20.0 9.1
139.7 mm	5.500 139.7	5.88 149.4	6.30 160.0	2.18 55.4	—	—	3.34 84.8	6.25 158.8	2.17 55.2	0.13 3.3	1.12 28.5	0.50 12.7	0.75 19.1	—	—	12.10 307.3	1.74 44.2	—	16.8 7.6	20.0 9.1
6 150	6.625 168.3	5.88 149.4	7.30 185.4	2.33 59.2	0.42 10.6	—	3.83 97.3	6.75 171.5	2.17 55.2	0.13 3.3	1.12 28.5	0.50 12.7	0.75 19.1	—	—	12.10 307.3	1.74 44.2	—	20.0 9.1	23.2 10.5
159.0mm †	6.250 159.0	5.88 149.4	7.30 185.4	2.33 59.2	0.42 10.6	—	3.83 97.3	6.75 171.5	2.17 55.2	0.13 3.3	1.12 28.5	0.50 12.7	0.75 19.1	—	—	12.10 307.3	1.74 44.2	—	20.0 9.1	23.2 10.5
165.1 mm	6.500 165.1	5.88 149.4	7.30 185.4	2.33 59.2	0.42 10.6	—	3.83 97.3	6.75 171.5	2.17 55.2	0.13 3.3	1.12 28.5	0.50 12.7	0.75 19.1	—	—	12.10 307.3	1.74 44.2	—	20.0 9.1	23.2 10.5
8 200	8.625 219.1	5.33 135.4	10.00 254.0	2.33 59.2	1.47 37.4	0.80 20.3	5.00 127.0	8.00 203.2	2.17 55.2	0.13 3.3	1.30 33.0	—	0.88 22.2	14.00 355.6	1.51 38.4	—	—	—	34.3 15.6	37.5 17.0
10 250	10.750 273.0	6.40 162.6	12.25 311.2	3.00 76.2	1.81 45.9	1.41 35.8	6.13 155.7	9.75 247.7	2.76 70.1	0.13 3.3	2.25 57.2	—	1.25 31.8	11.66 296.2	4.50 114.3	—	—	7.50 190.5	72.0 32.7	84.0 38.1
12 300	12.750 323.9	6.50 165.1	14.25 362.0	3.00 76.2	2.80 71.0	2.30 58.4	7.13 181.1	10.75 273.1	2.76 70.1	0.13 3.3	2.24 56.9	—	1.25 31.8	11.66 296.2	4.50 114.3	—	—	7.50 190.5	88.0 39.9	100.0 45.4
14 – 24 350 – 600	AGS™	See Style Vic-300 MasterSeal AGS Butterfly Valve, pg. 5-12, Request Publication 20.06																		

- Pressure enhanced rubber seat within the valve body seals equally on both sides of the valve
- Stem bearings and pressure enhanced rubber seat keeps torque consistent over the life of the valve
- Standard ISO mounting flange for actuation
- 10 position handle is infinitely variable, padlockable and includes memory stop.
- Full bi-directional shut-off and dead end service capabilities to the full pressure rated up to 300psi/2065kPa
- Sizes from 2–12"/50–300mm

@ See pg.3-4 for flow coefficient.

† Contact Victaulic for availability.

IMPORTANT NOTE:

2–8"/50–200 mm sizes are ISO Flange Designation F07; 10"/250 mm and 12"/300 mm sizes are ISO Flange Designation F10.

Valves – Butterfly Valves

Vic-300 MasterSeal Butterfly Valve

WITH GEAR OPERATOR

For Complete Information
Request Publication **08.20**

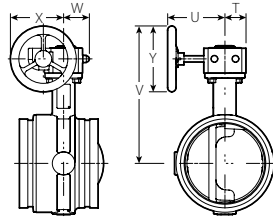

VALVE WITH GEAR OPERATOR HANDLE
TYPICAL 2-6"/50-165.1 mm SIZES

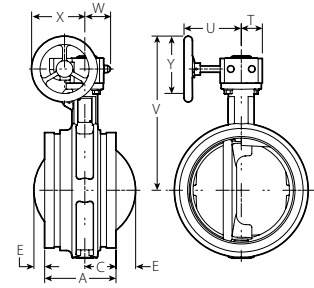

VALVE WITH GEAR OPERATOR HANDLE
TYPICAL 8-12"/200-300 mm SIZES

Size		Dimensions										Approx. Weight Each	Flow Coefficient@ (Fully Open)
Nominal Size Inches mm	Actual Outside Dia. Inches mm	A Inches mm	C Inches mm	E Inches mm	T Inches mm	U Inches mm	V Inches mm	W Inches mm	X Inches mm	Y Inches mm	Lbs. kg	C _v Values K _v Values	
2 50	2.375 60.3	3.21 81.5	1.44 36.6	—	1.58 40.1	4.43 112.5	6.84 173.7	1.75 44.5	3.64 92.5	3.94 100.1	6.0 2.7	115 99.5	
2½ 65	2.875 73.0	3.77 95.8	1.77 45.0	—	1.58 40.1	4.43 112.5	7.28 184.9	1.75 44.5	3.64 92.5	3.94 100.1	7.5 3.4	260 224.9	
76.1 mm	3.000 76.1	3.77 95.8	1.77 45.0	—	1.58 40.1	4.43 112.5	7.28 184.9	1.75 44.5	3.64 92.5	3.94 100.1	7.5 3.4	260 224.9	
3 80	3.500 88.9	3.77 95.8	1.77 45.0	—	1.58 40.1	4.43 112.5	7.53 191.3	1.75 44.5	3.64 92.5	3.94 100.1	8.5 3.9	440 380.6	
4 100	4.500 114.3	4.63 117.6	2.18 55.4	—	1.58 40.1	4.43 112.5	8.28 210.3	1.75 44.5	3.64 92.5	3.94 100.1	11.8 5.4	820 709.3	
108.0 mm †	4.250 108.0	4.63 117.6	2.18 55.4	—	1.58 40.1	4.43 112.5	8.28 210.3	1.75 44.5	3.64 92.5	3.94 100.1	11.8 5.4	820 709.3	
5 125	5.563 141.3	5.88 149.4	2.18 55.4	—	1.97 50.0	4.84 122.9	9.81 249.2	2.28 57.9	4.43 112.5	4.92 125.0	20.8 9.4	1200 1038.0	
133.0 mm †	5.525 133.0	5.88 149.4	2.18 55.4	—	1.97 50.0	4.84 122.9	9.81 249.2	2.28 57.9	4.43 112.5	4.92 125.0	20.8 9.4	1200 1038.0	
139.7 mm	5.500 139.7	5.88 149.4	2.18 55.4	—	1.97 50.0	4.84 122.9	9.81 249.2	2.28 57.9	4.43 112.5	4.92 125.0	20.8 9.4	1200 1038.0	
6 150	6.625 168.3	5.88 149.4	2.33 59.2	—	1.97 50.0	4.84 122.9	10.31 261.9	2.28 57.9	4.43 112.5	4.92 125.0	24.0 10.9	1800 1557.0	
159.0 mm †	6.250 159.0	5.88 149.4	2.33 59.2	—	1.97 50.0	4.84 122.9	10.31 261.9	2.28 57.9	4.43 112.5	4.92 125.0	24.0 10.9	1800 1557.0	
165.1 mm	6.500 165.1	5.88 149.4	2.33 59.2	—	1.97 50.0	4.84 122.9	10.31 261.9	2.28 57.9	4.43 112.5	4.92 125.0	24.0 10.9	1800 1557.0	
8 200	8.625 219.1	5.33 135.4	2.33 59.2	0.80 20.3	1.97 50.0	4.84 122.9	11.56 293.6	2.28 57.9	4.43 112.5	4.92 125.0	38.3 17.4	3400 2941.0	
10 250	10.750 273.0	6.40 162.6	3.00 76.2	1.41 35.8	2.88 73.2	7.76 197.1	15.13 384.3	3.25 82.6	6.30 160.0	7.87 199.9	81.5 39.0	5800 5017.0	
12 300	12.750 323.9	6.50 165.1	3.00 76.2	2.30 58.4	2.88 73.2	7.76 197.1	16.13 409.7	3.25 82.6	6.30 160.0	7.87 199.9	97.5 44.2	9000 7785.0	

AGS™ See Style Vic-300 MasterSeal AGS Butterfly Valve, pg. 5-12, Request Publication 20.06

@ C_v/K_v values for flow of water at +60°F/16°C with valve fully open.

† Contact Victaulic for availability.

IMPORTANT NOTE:

2-8"/50-200mm sizes are ISO Flange Designation F07; 10"/250mm and 12"/300mm sizes are ISO Flange Designation F10.

CHAIN WHEEL AND GUIDE FOR GEAR OPERATED BUTTERFLY VALVES

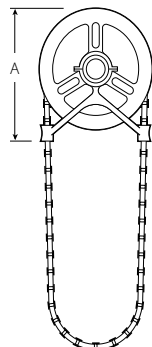

Size	Dimensions			Approx. Weight Each
Nominal Size Inches mm	Sprocket Size	Chain Wheel Size (Dia.) Inches mm	A Inches mm	Lbs. kg
2-4 50-100	0	4.00 10	4.63 118	2.0 0.9
5-8 125-200	1	5.75 146	6.38 162	4.0 1.8
10-12 250-300	2	9.00 229	10.50 267	10.0 4.5

IMPORTANT NOTES:

Chain wheels are mounted to the gear operator hand wheels. Sprocket rim and guide arms are made of cast aluminum and chain is galvanized steel. Always specify length of chain required. For insulation and locking device, contact Victaulic for details.

Valves – Triple Service Valves

Triple Service Valve Assembly

For Complete Information Request Publication **08.09**



- Victaulic tri-service valves provide shut-off, throttling and non-slam check service in a single assembly
- Series 779 check valve features a venturi-like inlet that is drilled, tapped, and plugged to receive flow-measuring taps
- The 779 check valve can be combined with either the Vic-300 MasterSeal butterfly valve or the Series 377 Vic-Plug balancing valve
- For 2½–3"/65–80 mm configurations use a Series 716 check valve
- Both configurations are available with memory stop
- Working pressures for the 2½–12"/65–300 mm butterfly/check combination are 300 psi/2065 kPa and 175 psi/1200 kPa for the 3–12"/80–300 mm plug/check combination

TRIPLE SERVICE BUTTERFLY/CHECK VALVE ASSEMBLY

Size		Dimensions				Approx. Weight Each	
Nominal Size Inches mm	Actual Outside Diameter Inches mm	Center to Top		Center to Bottom Inches mm	End to End Inches mm	Manual Handle Lbs. kg	Gear Operator Lbs. kg
		Handle Inches mm	Gear Inches mm				
2½ 65	2.875 73.0	5.62 143	6.72 170	2.13‡ 54	7.75 197	11.6 5.3	12.7 5.8
3 80	3.500 88.9	5.62 143	7.02 178	2.50‡ 64	8.12 206	13.5 6.1	14.6 6.6
4 100	4.500 114.3	7.62 193	8.08 205	4.00 102	14.38 365	37.0 16.8	40.1 18.2
5 125	5.563 141.3	8.12 206	8.60 218	4.62 117	16.50 419	52.0 23.6	55.0 25.0
6 150	6.625 168.3	8.62 219	10.58 269	5.00 127	17.50 444	69.0 31.3	72.0 32.7
8 200	8.625 219.1	10.50 267	12.50 318	6.12 155	19.50 495	125.0 56.7	125.0 56.7
10 250	10.750 273.0	—	14.05 357	7.18 182	23.50 597	—	187.0 84.8
12 300	12.750 323.9	—	15.37 390	8.12 206	26.12 663	—	260.0 117.9

‡ Based on Style 77 couplings. When using Style 07 dimensions are 1.94"/49 mm for 2½"/65 mm size and 2.25"/57 mm for 3"/80 mm size.

TRIPLE SERVICE PLUG/CHECK VALVE ASSEMBLY

Size		Dimensions				Approx. Weight Each	
AWWA Nominal Size Inches mm	AWWA Outside Diameter Inches mm	Center to Top		Center to Bottom Inches mm	End to End Inches mm	Manual Handle Lbs. kg	Gear Operator Lbs. kg
		Handle Inches mm	Gear Inches mm				
3 80	3.96 100.6	8.25 210	12.38 315	3.75 95	12.25 311	40.0 18.1	50.0 22.7
4 100	4.80 121.9	8.75 222	12.87 327	4.44 113	18.62 473	60.0 27.2	70.0 31.8
6 150	6.90 175.3	10.00 254	13.75 349	5.56 141	22.00 559	110.0 49.9	130.0 59.0
8 200	9.05 229.9	—	17.10 434	6.87 175	25.50 648	180.0 81.6	210.0 95.3
10 250	11.10 281.9	—	22.63 575	8.00 203	30.00 762	—	307.0 139.3
12 300	13.20 335.3	—	24.50 622	9.50 241	33.50 851	—	412.0 186.9

IMPORTANT NOTE:

For connecting Vic-Plug valve to Vic-check valve or IPS steel pipe (3–12"/80–300 mm), refer to Style 307 Transition coupling in 23.03.

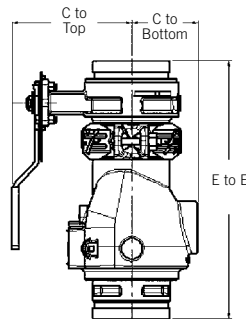

TYPICAL 2½–3"/65–80 mm SIZES

Vic-300 MasterSeal butterfly valve and Series 716 Vic-Check valve and Style 07 coupling

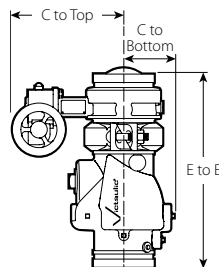

TYPICAL 4–12"/100–300 mm SIZES

Vic-300 MasterSeal gear operator butterfly valve and Series 712 or 779 Vic-Check valve and Style 07 coupling

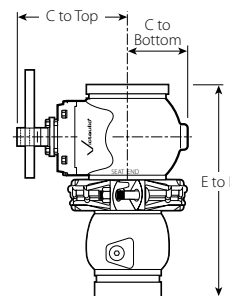

TYPICAL 3"/80 mm SIZE

Series 377 Vic-Plug with manual handle, Series 716 Vic-Check valve, and Style 307 coupling

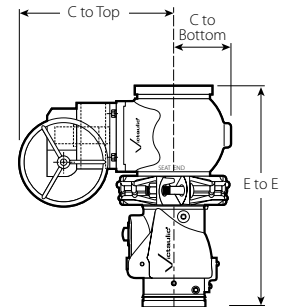

TYPICAL 4–12"/100–300 mm SIZES

Series 377 Vic-Plug with gear operator, Series 779 Vic-Check valve, and Style 307 coupling

IMPORTANT NOTE: ASSEMBLY REQUIRED WITH EITHER STYLE 07 ZERO-FLEX RIGID COUPLINGS OR STYLE 77 STANDARD FLEXIBLE COUPLINGS.

Valves – Butterfly Valves

Butterfly Valve

SERIES 700

For Complete Information
Request Publication **08.05**



- Designed for bubble-tight shut-off for pressure rated up to 200psi/1400kPa
- Narrow disc design for low pressure drop performance
- Self-centering for positive shut-off
- Available with EPDM for water services to +230°F/+110°C
- Nitrile for oil services to 180°F/+82°C liners
- Body is fully rubber lined, standard disc is aluminum bronze (also available in 316 stainless steel)
- Lockable feature sizes 1½–6"/40–150mm and 165.1 mm

STANDARD PROFILE BFV

Size		Dimensions					Approx. Wgt. Each
Nominal Size Inches mm	Actual Outside Dia. Inches mm	A	B	D	G	K	Lbs. kg
1½ 40	1.900 48.3	3.63 92.2	3.38 85.9	1.63 41.4	5.50 139.7	4.44 112.8	2.8 1.3
2 50	2.375 60.3	4.06 103.1	3.19 81.0	1.87 47.5	5.50 139.7	4.71 119.6	3.3 1.5
2½ 65	2.875 73.0	4.87 123.7	3.81 96.8	2.50 63.5	7.00 177.8	5.31 134.9	6.4 2.9
3 80	3.500 88.9	5.62 142.7	3.81 96.8	2.75 69.9	7.00 177.8	5.62 142.7	6.8 3.1
4 100	4.500 114.3	7.00 177.8	4.56 115.8	3.50 88.9	9.00 228.6	6.69 179.9	12.1 5.5
5 125	5.563 141.3	8.50 215.9	5.81 147.6	4.00 101.6	12.00 304.8	8.25 209.6	26.1 11.8
6 150	6.625 168.3	9.50 241.3	5.81 147.6	4.50 114.3	12.00 304.8	8.78 223.0	32.5 14.7
165.1 mm	6.500 165.1	9.50 241.3	5.81 147.6	4.50 114.3	12.00 304.8	8.78 223.0	30.5 13.8

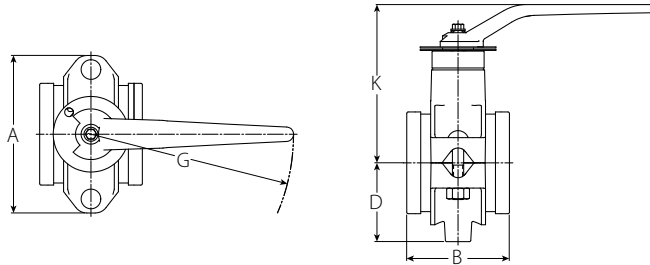

1½–6"/40–150mm SIZES (TYPICAL)

Valves – Check Valves

Vic Check Valve

SERIES 716

For Complete Information
Request Publication **08.08**



TYPICAL 2½–3"/65–80 mm SIZES



TYPICAL 4–12"/100–300 mm SIZES

Size		Dimensions										Approx. Wgt. Each	Flow Coefficient@ (Fully Open)
Nominal Size Inches mm	Actual Outside Diameter Inches mm	A End to End Inches mm	B Overall Width Inches mm	C Inches mm	D Inches mm	E Inches mm	J Inches mm	K Inches mm	P Inches mm	R Inches mm	Lbs. kg		
2½ 65	2.875 73.0	3.88 99	4.25 108	3.60 91	—	—	—	—	—	—	3.6 1.6	140 121.1	
76.1 mm	3.000 76.1	3.88 99	4.25 108	3.60 91	—	—	—	—	—	—	3.6 1.6	140 121.1	
3 80	3.500 88.9	4.25 108	5.06 129	4.19 106	—	—	—	—	—	—	4.5 2.0	250 216.3	
4 100	4.500 114.3	9.63 245	6.00 152	3.90 99	2.75 70	3.50 89	2.00 51	4.50 114	3.50 89	3.35 85	16.0 7.3	390 337.4	
5 125	5.563 141.3	10.50 267	6.80 173	4.50 114	4.17 106	4.17 106	2.15 55	5.88 149	4.08 104	4.02 102	20.0 9.1	700 605.5	
139.7 mm	5.500 139.7	10.50 267	6.80 173	4.50 114	4.17 106	4.17 106	2.15 55	5.88 149	4.08 104	4.02 102	27.0 12.3	700 605.5	
6 150	6.625 168.3	11.50 292	8.00 203	5.00 127	4.50 114	4.50 114	2.38 61	6.67 169	4.73 120	3.89 99	28.0 12.7	1000 865.0	
165.1 mm	6.500 165.1	11.50 292	8.00 203	5.00 127	4.50 114	4.50 114	2.38 61	6.67 169	4.73 120	3.89 99	28.0 12.7	1000 865.0	
8 200	8.625 219.1	14.00 356	9.88 251	6.10 155	5.05 128	5.65 144	2.15 55	8.75 222	5.70 145	5.75 146	40.0 18.1	1800 1157.0	
10 250	10.750 273.0	17.00 432	12.00 305	7.10 180	5.96 151	6.69 170	2.15 55	10.92 277	6.93 176	—	100.0 45.4	3000 2595.0	
12 300	12.750 323.9	19.50 495	14.00 356	8.10 206	6.91 176	7.64 194	2.51 64	12.81 325	7.93 201	—	140.0 63.5	4200 3633.0	
14 – 24 350 – 600	AGS™ See AGS Series W715 Check Valve, pg. 5-11												

@ C_v/K_v values for flow of water at +60°F/16°C with valve fully open.

IMPORTANT NOTES:

Placement of check valves too close to sources of unstable flow will shorten the life of the valve and potentially may damage the system. To extend valve life, valves should be installed a reasonable distance downstream from pumps, elbows, expanders, reducers or other similar devices. Sound piping practices dictate a minimum of five (5) times the pipe diameter for general use. Distances between three (3) and five (5) diameters are allowable provided the flow velocity is less than eight (8) ft. per second (2.4 mps). Distances less than three (3) diameters are not recommended and will violate the Victaulic product warranty.

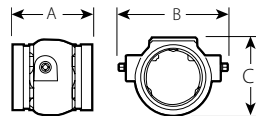

TYPICAL 2½–3"/65–80 mm SIZES

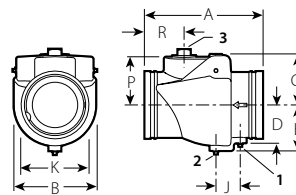

TYPICAL 4–8"/100–200 mm SIZES

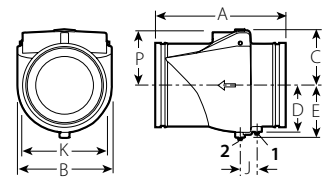

TYPICAL 10–12"/250–300 mm SIZES

- 1 ½" NPT Upstream drain (optional)
- 1 ½" NPT downstream drain (optional)
- 2" NPT drain (optional)

- Utilizes spring-assisted, single-disc design
- Achieves a leak-free seal with as little as 5ft./1.5m of head
- Installed in horizontal and vertical positions (upward flow only)
- Vic-Check valves combine high pressure capabilities with low pressure drop performance
- The grooved end design permits fast, easy installation
- Drains are provided both upstream and downstream of the disc
- Every valve factory tested to its working pressure rated up to 300psi/2065kPa
- Sizes from 2½–12"/65–300mm
- AGS Series W715 check valve available for sizes 14–24"/350–600mm, see pg. 5-10

Valves – Check Valves

Venturi Check Valve

SERIES 779

For Complete Information
Request Publication **08.10**



- CAD-designed hydrodynamic inlet profile provides a natural venturi as part of the valve
- Inlet is drilled, tapped, and plugged, ready to receive the flow kit (optional in Canada)
- Venturi provides much greater measurement accuracy, valve turbulence and interference across the valve seat is negligible
- Twin taps on both sides provide positioning of measurement outlets for convenient meter connection and accurate flow measurement independent of the style of throttling valve or the position of the throttling element (ball, plug, disc, etc.)
- All sizes can be installed in horizontal and vertical positions (upward flow only)
- Provides leak-free sealing under conditions as low as 5 ft./1.5 m of head pressure
- Every valve is factory tested and pressure rated up to 300psi/2065 kPa
- Sizes from 4–12"/100–300mm

Size		Dimensions										Approx. Wgt. Each	Flow Coefficient@ (Fully Open)
Nominal Size Inches mm	Actual Outside Diameter Inches mm	A End to End Inches mm	B Inches mm	C Inches mm	D Inches mm	E Inches mm	F Inches mm	G Inches mm	K Inches mm	P Inches mm	Lbs. kg	C _v Values K _v Values	
4† 100	4.500 114.3	9.63 245	5.88 149	3.88 99	2.75 70	3.50 89	1.50 38	2.38 60	4.50 114	3.50 89	16.0 7.3	390 337.4	
5† 125	5.563 141.3	10.50 267	6.75 171	4.50 114	4.25 108	4.25 108	1.65 42	2.38 60	5.88 149	4.08 104	20.0 9.1	700 605.5	
139.7mm†	5.500 139.7	10.50 267	6.75 171	4.50 114	4.25 108	4.25 108	1.65 42	2.38 60	5.88 149	4.08 104	20.0 9.1	700 605.5	
6† 150	6.625 168.3	11.50 292	8.00 203	5.00 127	4.50 114	4.50 114	1.58 40	2.68 68	6.68 170	4.75 121	28.0 12.7	1000 865.0	
165.1mm†	6.500 165.1	11.50 292	8.00 203	5.00 127	4.50 114	4.50 114	1.58 40	2.68 68	6.68 170	4.75 121	28.0 12.7	1000 865.0	
8* 200	8.625 219.1	14.00 356	9.88 251	6.06 154	5.06 129	5.68 144	1.75 44	3.25 83	8.88 226	5.75 146	40.0 18.1	1800 1557.0	
10* 250	10.750 273.0	17.00 432	12.00 305	7.12 181	6.00 152	6.68 170	1.82 46	3.94 100	10.94 278	6.94 176	100.0 45.4	3000 2595.0	
12* 300	12.750 323.9	19.50 495	14.00 356	8.06 205	6.91 176	7.68 195	1.82 46	3.32 84	12.82 326	7.93 201	140.0 63.5	4200 3633.0	

† Port "L" located 45° off center line of valve body.

* Both ports on center line of valve body.

@ C_v/K_v values for flow of water at +60°F/16°C with valve fully open.

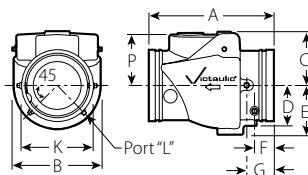

TYPICAL 4"/100mm SIZES

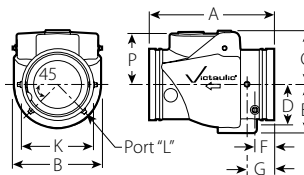

TYPICAL 5–6"/125–165.1 mm SIZES

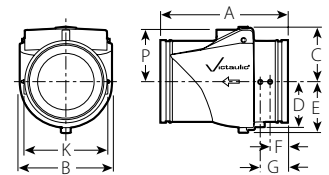

TYPICAL 8–12"/200–300 mm SIZES

Valves – Check Valves

Swinger® Swing Check Valve

SERIES 712 SERIES 713

For Complete Information
Request Publication 08.11



SERIES 712



SERIES 713

SERIES 712

Size		Max. Work Pressure psi kPa	Dimensions					Approx. Wgt. Each Lbs. kg	Flow Coefficient@ (Fully Open) C _v Values K _v Values
Nominal Size Inches mm	Actual Outside Dia. Inches mm		A End to End Inches mm	C Inches mm	D Inches mm	E Inches mm	F Inches mm		
2 50	2.375 60.3	300 2065	9.00 229	1.81 46	4.88 124	4.38 111	6.38 162	11.6 55.3	78 67.5
2½ 65	2.875 73.0	300 2065	9.25 235	2.25 57	5.50 140	5.69 145	7.69 195	18.0 8.2	125 108.1
3 80	3.500 88.9	300 2065	10.75 273	2.50 64	5.75 146	6.25 159	9.00 229	22.5 10.2	210 181.7
4 100	4.500 114.3	300 2065	12.00 305	3.38 86	7.63 194	7.96 202	10.75 273	38.0 17.2	358 309.7

SERIES 713

2 50	2.375 60.3	1000 6900	9.00 229	1.81 46	4.88 4.69	4.96 119	6.75 172	12.0 5.4	78 67.5
---------	---------------	--------------	-------------	------------	--------------	-------------	-------------	-------------	------------

@ C_v/K_v values for flow of water at +60°F/16°C with valve fully open.

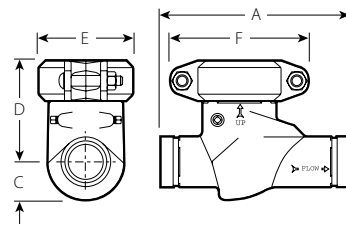

SERIES 712
TYPICAL 2-4"/50-100mm SIZES

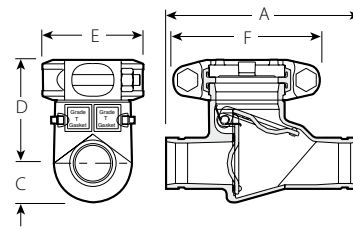

SERIES 713
TYPICAL 2"/50mm SIZE

- Designed for use with standard Victaulic grooved fittings and couplings
- Large closure access bonnet permits easy internal coating for corrosive services
- 316 stainless steel clapper features a bonded disc for coating protection
- Series 712 and Series 713 should not be installed in vertical pipelines

SERIES 712:

- Pressure rated up to 300psi/2065kPa
- Sizes from 2-4"/50-100mm

SERIES 713:

- Can be used with high pressure lines rated up to 1000psi/6900kPa
- Size for 2"/50mm only

Valves – Plug Valves

Vic-Plug Balancing Valve

SERIES 377

For Complete Information
Request Publication 08.12



VALVE DIMENSIONS

Size		Dimensions										Approx. Wgt. Each		Flow Coefficient@ (Fully Open) C _v Values K _v Values
AWWA Nominal Size Inches mm	AWWA Outside Diameter Inches mm	A End to End Inches mm	C Inches mm	D Inches mm	F Inches mm	G Inches mm	H Inches mm	K Inches (mm)	M Inches mm	V Inches (mm)	Valve with Gear Operator Lbs. kg	Valve with Lever Handle Lbs. kg		
3* 80	3.96 100.6	8.00 203	3.75 95	4.25 108	6.56 167	—	4.00 102	2.00 51	4.00 102	18.50 470	32.0 14.5	32.0 14.5	600 519.0	
4* 100	4.80 121.9	9.00 229	4.44 113	4.75 121	7.74 197	—	4.50 114	2.00 51	4.00 102	18.50 470	42.0 19.1	39.0 17.7	1040 899.6	
6* 150	6.90 175.3	10.50 267	5.50 140	7.50 191	10.32 262	—	5.25 133	2.00 51	—	18.50 470	80.0 36.3	74.0 33.6	2100 1816.5	
8 200	9.05 229.9	11.50 292	6.87 175	10.80 274	12.30 312	16.38 416	5.75 145	—	—	—	120.0 55.0	—	3850 3330.3	
10 250	11.10 281.9	13.00 330	8.00 203	12.00 305	14.78 375	18.75 476	6.50 165	—	—	—	185.0 84.0	—	5500 4757.5	
12 300	13.20 335.3	14.00 356	9.50 241	13.75 349	17.00 432	21.00 533	7.00 178	—	—	—	240.0 109.0	—	8400 7266.0	

* 3"/80mm, 4"/100mm, 6"/150mm valves do not include side support lugs.

@ C_v/K_v values for flow of water at +60°F/16°C with valve fully open.

IMPORTANT NOTE:

Gear operators can be installed in various positions, contact Victaulic for details.

- Only eccentric grooved end plug valve made specifically for throttling services
- Cast of ductile iron and coated with alkyd enamel
- Eccentric design assures shut-off sealing up to 175psi/1200kPa on 3–12"/80–300mm
- For 3–12"/80–300mm systems Victaulic Style 307 Transition couplings are available to directly connect Vic-Plug valves to grooved end steel and other IPS pipe—refer to Publication 23.03 for details

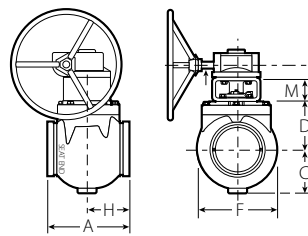

VALVE WITH GEAR OPERATOR
TYPICAL 3–6"/80–150mm SIZES

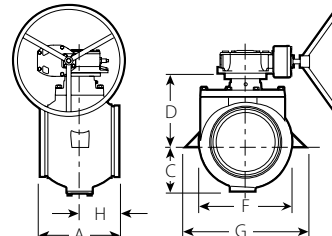

VALVE WITH GEAR OPERATOR
TYPICAL 8–12"/200–300mm SIZES

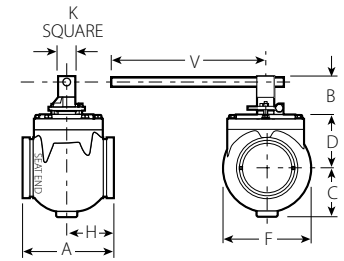

VALVE WITH LEVER HANDLE
TYPICAL 3–6"/80–150mm SIZES

GEAR OPERATOR DIMENSIONS

Gear Oper. Style No.	Dimensions										Turns to Close No.	Approx. Wgt. Each Lbs. kg
	J Inches mm	L Inches mm	N Dia. Inches mm	O Inches mm	P Inches mm	Q Inches mm	R Dia. Inches mm	S Inches mm	T Inches mm	U Dia. Inches mm		
MX	4.76 121	2.07 53	6.00 152	4.00 102	1.13 29	1.30 33	0.63 16	4.00 102	1.95 50	0.19 5	7.5	7.5 3.4
MZ	5.50 140	2.62 67	10.00 250	5.00 127	1.25 32	1.30 33	0.63 16	4.50 114	2.36 60	0.19 5	7.5	15.0 6.8
MV	7.25 184	3.29 84	18.00 457	9.00 229	1.62 41	2.25 57	0.88 22	6.00 152	2.63 67	0.25 6	7.8	20.0 9.1
MA	8.24 209	3.55 90	18.00 457	10.00 254	1.75 45	2.25 57	0.88 22	7.00 178	3.38 86	0.25 6	7.8	33.0 15.0
MC	11.12 283	4.03 102	18.00 457	10.38 264	1.87 48	2.25 57	1.00 25	7.38 188	5.38 137	0.25 6	18	68.0 30.8

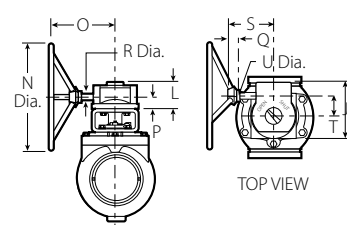

TYPICAL 3–6"/80–150mm SIZES

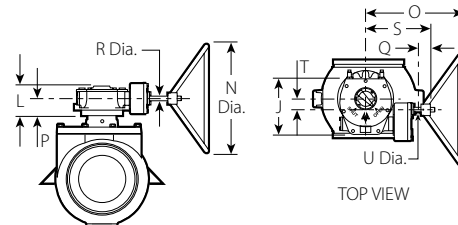

TYPICAL 8–12"/200–300mm SIZES

Valves – Ball Valves

Brass Body Ball Valve

SERIES 722

For Complete Information
Request Publication 08.15



- Standard port, female threaded end ball valve
- Constructed from forged brass
- Pressure rated up to 600psi/4135kPa WOG service
- Sizes from ¼–2”/8–50mm

Size		Dimensions				Approx. Weight Each	Flow Coefficient@ (Fully Open) C _v Values K _v Values
Nominal Size Inches mm	Actual Outside Dia. Inches mm	A Inches mm	B Inches mm	C Inches mm	F Inches mm		
¼ 8	0.540 13.7	1.54 39	0.77 20	1.03 26	1.65 42	0.2 0.09	7 6.1
¾ 10	0.675 17.1	1.77 45	0.88 22	1.28 33	3.07 78	0.3 0.14	7 6.1
½* 15	0.084 21.3	2.13 54	1.06 27	1.33 34	3.07 78	0.4 0.18	10 8.7
¾* 20	1.050 26.7	2.44 62	1.22 31	1.79 45	3.78 96	0.7 0.32	25 21.6
1* 25	1.315 33.4	2.95 75	1.48 37	1.95 50	3.78 96	1.0 0.45	37 32.0
1¼* 32	1.660 42.2	3.31 84	1.65 42	2.17 55	3.78 96	1.5 0.68	50 43.3
1½* 40	1.900 48.3	3.66 93	1.83 46	2.68 68	5.43 138	2.1 0.95	87 75.3
2* 50	2.375 60.3	4.21 107	2.11 53	2.89 73	5.43 138	2.4 1.09	110 95.2

@ C_v/K_v values for flow of water at +60°F/16°C with valve fully open.

* Valve sizes ½"/15 mm and above are UL Listed at 175 psi/1200 kPa and FM Approved at 600 psi/4135 kPa for ½"/15 mm and ¾"/20 mm sizes and 500 psi/3450 kPa for 1 – 2"/25 – 50 mm sizes.

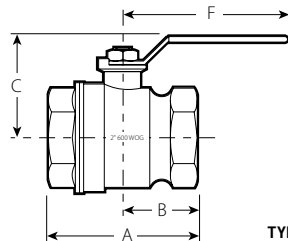

TYPICAL FOR ALL SIZES

Vic® Ball Valves

SERIES 721

For Complete Information
Request Publication 08.14



- Streamlined design provides excellent flow characteristics
- Standard port, end-entry valve designed for 800 psi/5515 kPa WOG service
- Ductile Iron valve body and end cap
- Supplied standard with manual handles; pinned handle extensions available
- Reinforced Tetrafluoroethylene (TFE) seal rated to +450°F/+232°F
- Sizes 4-6" / 100-150mm

Size		Dimensions – Inches/mm					Approx. Weight Each	
Nominal Size Inches mm	Actual Outside Dia. Inches mm	End to End A	Height B	C	Diameter D	E		F
4* 114.3	4.500 114.3	8.25 210	6.92 176	4.50 114	6.00 152	5.21 132	16.13 410	32.4 14.7
6 168.3	6.625 168.3	10.10 257	9.14 232	5.30 135	8.00 203	7.26 184	28.13 715	75.0 34.0

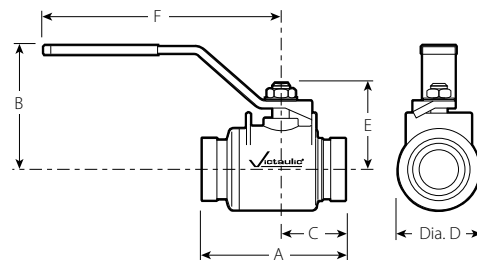

Valves – Ball Valves

Vic-Ball Valve

SERIES 726

For Complete Information
Request Publication **08.23**



Size		Dimensions											Approx. Wgt Each	Flow Coefficient@ (Fully Open)
Nominal Size	Actual Out. Dia.	A	B	C	D	DA	E	F	H	J	K	L		
Inches mm	Inches mm	Inches mm	Inches mm	Inches mm	Inches mm	Inches mm	Inches mm	Inches mm	Inches mm	Inches mm	Inches mm	Inches mm		
1½ 40	1.900 48.3	5.12 130	2.00 51	2.36 60	1.25 32	1.50 38	1.78 45	1.90 48	3.00 76	0.28 7	0.56 14	6.97 177	4.4 2.0	130 112.5
2 50	2.375 60.3	5.50 140	2.64 67	2.48 63	1.50 38	2.00 51	2.25 57	2.38 60	3.31 84	0.34 9	0.56 14	6.97 177	6.5 3.0	180 155.7
2½ 65	2.875 73.0	6.25 159	3.03 77	2.80 71	1.97 50	2.50 64	2.72 69	2.88 73	4.00 102	0.34 9	0.56 14	9.84 250	10.4 4.7	340 294.1
3 80	3.500 88.9	6.56 167	3.50 89	3.15 80	2.50 64	3.00 76	3.34 85	3.50 89	4.53 115	0.34 9	0.56 14	9.84 250	14.9 6.8	600 519.0
4 100	4.500 114.3	8.25 210	—	3.35 85	2.99 76	4.00 102	4.33 111	4.52 115	5.48 139	0.34 9	0.61 15	15.67 398	41.5 18.9	650 562.3
6 150	6.625 168.3	10.10 257	—	4.53 115	4.00 102	6.00 152	6.46 164	6.64 169	6.48 165	0.34 9	0.61 15	18.07 459	78.5 35.7	800 692.0

@ C_v/K_v values for flow of water at +60°F/16°C with valve fully open.

- High-pressure standard port ball valve with grooved ends
- Two-piece, end-entry valve
- Features floating ball for lower torque requirements
- NACE-MR-01-75 compliant
- Pressure rated up to 1000 psi/6900 kPa in sizes 1½–3"/40–80 mm
- Pressure rated up to 800 psi/5515 kPa for sizes 4–6"/100–150 mm
- Sizes from 1½–6"/40–150 mm

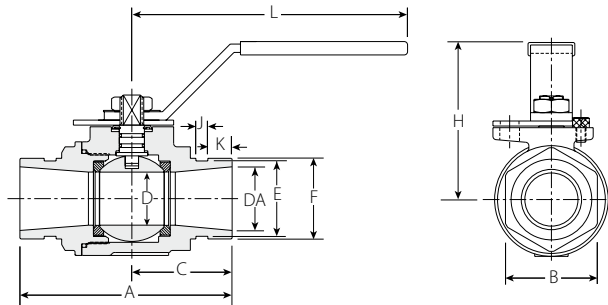

TYPICAL 1½–3"/40–80 mm SIZES

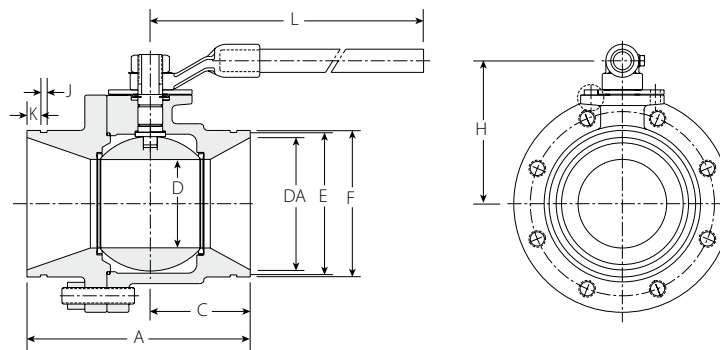

TYPICAL 4–6"/100–150 mm SIZES

Valves – Ball Valves

Vic-Ball Valve (cont'd)

SERIES 726 WITH GEAR OPERATOR

For Complete Information Request Publication **08.23**



Size		Dimensions						Approx. Wgt. Each	Flow Coefficient@ (Fully Open)
Nominal Size Inches mm	Actual Outside Dia. Inches mm	M Inches mm	N Inches mm	O Inches mm	P Inches mm	Q Inches mm	R Inches mm	Lbs. kg	C _v Values K _v Values
1½	1.900	6.03	4.29	1.58	3.94	2.64	1.75	7.1	130
40	48.3	153	109	40	100	92	44	3.2	112.5
2	2.375	6.30	4.29	1.58	3.94	2.64	1.75	9.1	180
50	60.3	160	109	40	100	92	44	4.1	155.7
2½	2.875	7.43	4.65	1.97	4.92	4.43	2.28	12.9	340
65	73.0	189	118	50	125	112	58	5.9	294.1
76.1 mm	3.000	7.43	4.65	1.97	4.92	4.43	2.28	12.9	340
	76.1	189	118	50	125	112	58	5.9	294.1
3	3.500	7.94	4.65	1.97	4.92	4.43	2.28	20.0	600
80	88.9	202	118	50	125	112	58	9.1	519.0
4	4.500	9.95	4.65	1.97	4.92	4.43	2.28	44.7	650
100	114.3	253	118	50	125	112	58	20.3	562.3
6	6.625	11.02	4.65	1.97	4.92	4.43	2.28	89.0	800
150	168.3	280	118	50	125	112	58	40.3	692.0
165.1 mm	6.500	11.02	4.65	1.97	4.92	4.43	2.28	89.0	800
	165.1	280	118	50	125	112	58	40.3	692.0

@ C_v/K_v values for flow of water at +60°F/16°C with valve fully open.

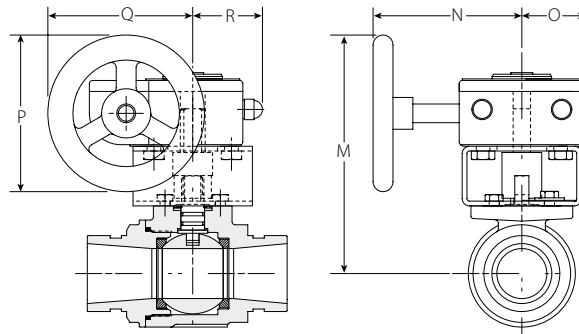

TYPICAL 1½–3" / 40–80 mm SIZES

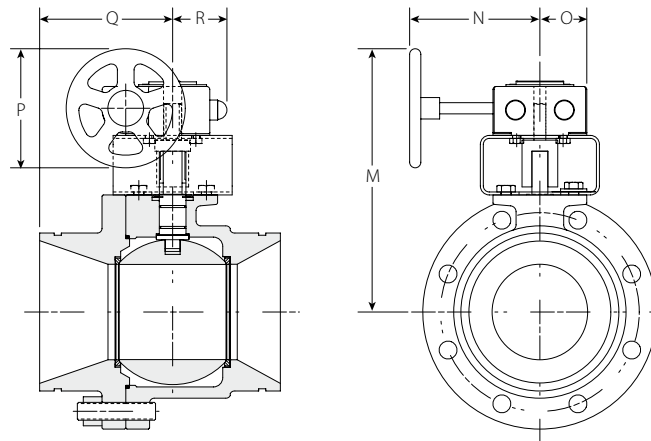

TYPICAL 4–6" / 100–150 mm SIZES

Valves – Circuit Balancing Valves

Balancing Valves

- Reliable, simple, and cost effective
- Full throttling range is achieved by 4, 8, 12, or 16 full turns
- Service governed by the connecting coupling gasket ratings for grooved and flanged valves
- Pressure rated up to 300 psi/2065 kPa for temperature ratings of +250°F/+120°C and -22°F/-30°C



Balancing Valve Solder End
TA SERIES 786, PG. 3-15



Balancing Valve Flanged End
TA SERIES 788, PG. 3-15



Balancing Valve Grooved End
TA SERIES 789, PG. 3-15



Union Port Fitting
SERIES 78U, PG. 3-16



Strainer/Ball Valve Combination
SERIES 78Y, PG. 3-17

COMPARISON OF THROTTLING CHARACTERISTICS

- This curve illustrates the advantage of the four (4) turn adjustment available with TA balancing valves ½–2"/15–50mm, valves 2½"/65mm and larger have 8, 12, or 16 turns
- A 90° fully open to closed valve requires just a 12° change in adjustment to equal 30% change in flow
- A 360° fully open to closed valve would require 96° change in adjustment to equal the same 30% change in the flow measurement
- TA balancing valves would require a 408° change in adjustment to equal the same 30% change in flow

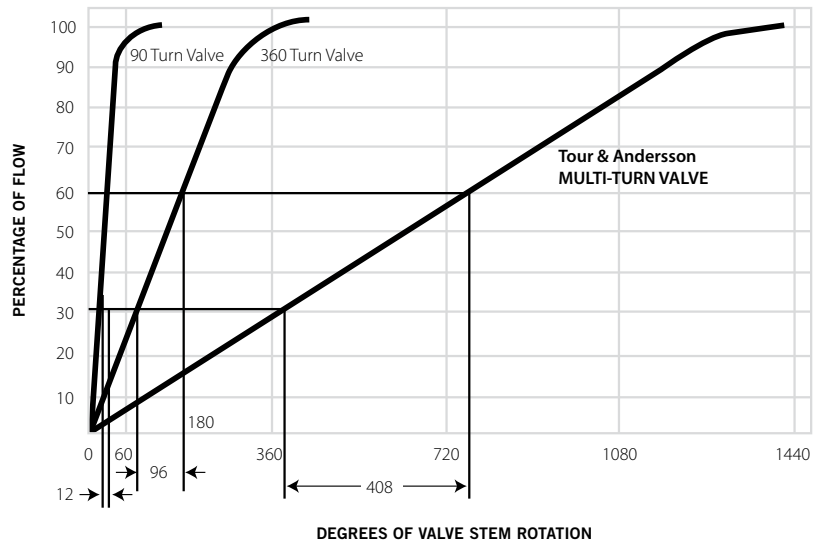

Valves – Circuit Balancing Valves

Balancing Valve

TA SERIES 786 Solder End
TA SERIES 787 Female Threaded End

For Complete Information
 Request Publication **08.16**

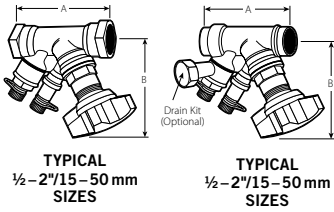

Size		TA Series 786 Solder End (300psi/2065 kPa) Balancing Valve			TA Series 787 NPT (Female) Threaded End (300psi/2065 kPa) Balancing Valve		
Nominal Size Inches mm	Actual Outside Diameter Inches mm	A End to End Inches mm	B Center to Top Inches mm	Approx. Weight Each Lbs. kg	A End to End Inches mm	B Center to Top Inches mm	Approx. Weight Each Lbs. kg
1/2 15	0.840 21.3	3.50 89	4.00 102	1.4 0.6	3.50 89	4.00 102	1.5 0.7
3/4 20	1.050 26.7	3.81 97	4.00 102	1.4 0.6	3.81 97	4.00 102	1.6 0.7
1 25	1.315 33.7	4.31 110	4.50 114	1.9 0.9	4.31 110	4.50 114	2.0 0.9
1 1/4 32	1.660 42.4	4.88 124	4.31 110	2.4 1.1	4.88 124	4.31 110	2.6 1.2
1 1/2 40	1.900 48.3	5.13 130	4.75 121	3.1 1.4	5.13 130	4.75 121	3.3 1.5
2 50	2.375 60.3	6.13 156	4.75 121	4.5 2.0	6.13 156	4.75 121	5.0 2.3

VALVE SELECTION GUIDE

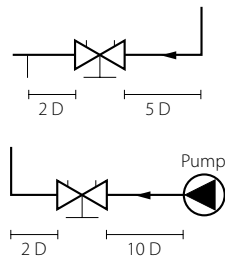

Size		TA Series 786 Solder End (300 psi/2065 kPa) Balancing Valve			TA Series 787 NPT (Female) Threaded End (300 psi/2065 kPa) Balancing Valve		
Nominal Size Inches mm	Actual Outside Diameter Inches mm	Minimum Flow GPM LPM	Nominal Flow GPM LPM	Maximum Flow GPM LPM	Minimum Flow GPM LPM	Nominal Flow GPM LPM	Maximum Flow GPM LPM
1/2 15	0.840 21.3	0.13 0.49	2.7 10.2	8.6 32.6	0.13 0.49	2.7 10.2	8.6 32.6
3/4 20	1.050 26.7	0.39 1.48	6.2 23.5	20.0 75.7	0.39 1.48	6.2 23.5	20.0 75.7
1 25	1.315 33.7	0.45 1.70	9.4 35.6	30.0 113.6	0.45 1.70	9.4 35.6	30.0 113.6
1 1/4 32	1.660 42.4	0.87 3.29	15.0 56.8	48.0 181.7	0.87 3.29	15.0 56.8	48.0 181.7
1 1/2 40	1.900 48.3	1.30 4.92	21.0 79.5	66.0 249.8	1.30 4.92	21.0 79.5	66.0 249.8
2 50	2.375 60.3	2.00 7.57	36.0 136.3	110.0 416.4	2.00 7.57	36.0 136.3	110.0 416.4

IMPORTANT NOTES:

Balancing valves should be sized in relation to the GPM flows (and not in relation to pipeline size). The Minimum Flow is calculated from the minimum open setting of the valve and a minimum pressure drop 1 Ft. WG (= 3 kPa). The Nominal Flow is calculated from the maximum open setting of the valve and the minimum recommended pressure drop, 2 Ft. WG (= 6 kPa). The Maximum Flow is calculated from the maximum open setting of the valve and the maximum pressure drop, 20 Ft. WG (= 60 kPa). A computer program, TA-Select, is available from Tour & Andersson for calculation of pre-setting values and other applications.

MEASURING ACCURACY:

The hand wheel zero position is calibrated and must not be changed. Valves have an accuracy of flow measurement of 2% to 3%* when used within their recommended flow range and installed in accordance with the figure below. * For the most accurate results, a Series 737 TA CBI-II should be used. However, any differential pressure meter may be used.

VALVES

Balancing Valve

TA SERIES 788 Flanged End
TA SERIES 789 Grooved End

For Complete Information
 Request Publication **08.16**

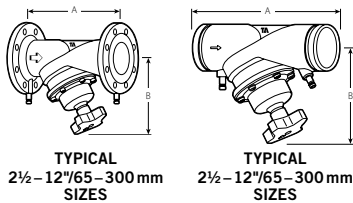

Size		TA Series 788 Flange End (250psi/1720 kPa) Balancing Valve			TA Series 789 Groove End (350psi/2400 kPa) Balancing Valve		
Nominal Size Inches mm	Actual Outside Diameter Inches mm	A End to End Inches mm	B Height Inches mm	Approx. Weight Each Lbs. kg	A End to End Inches mm	B Height Inches mm	Approx. Weight Each Lbs. kg
2 1/2 65	2.875 73.0	11.38 289	8.00 203	24.0 10.9	11.38 289	8.00 203	14.0 6.4
3 80	3.500 88.9	12.25 311	8.63 219	31.0 14.1	12.25 311	8.63 219	20.0 9.1
4 100	4.500 114.3	13.75 350	9.44 240	43.0 19.6	13.75 350	9.44 240	31.0 14.1
5 125	5.563 141.3	15.75 400	10.88 276	62.0 28.5	15.75 400	10.88 276	50.0 22.7
6 150	6.625 168.3	18.88 480	11.25 286	82.0 37.5	18.88 480	11.25 286	69.0 31.3
8 200	8.625 219.1	23.63 600	17.00 432	168.0 76.5	23.63 600	17.00 432	140.0 63.7
10 250	10.750 273.0	28.75 730	17.75 451	270.0 122.9	28.75 730	17.75 451	202.0 91.9
12 300	12.750 323.9	33.50 851	19.00 483	360.0 163.9	33.50 851	19.00 483	280.0 127.4

Valves – Circuit Balancing Valves

Balancing Valve

TA SERIES 788 Flanged End
TA SERIES 789 Grooved End

For Complete Information
 Request Publication **08.16**

VALVE SELECTION GUIDE

Size		TA Series 788 Flange End (250 psi/1720 kPa) Balancing Valve			TA Series 789 Groove End (350 psi/2400 kPa) Balancing Valve		
Nominal Size Inches mm	Actual Outside Diameter Inches mm	Minimum Flow GPM LPM	Nominal Flow GPM LPM	Maximum Flow GPM LPM	Minimum Flow GPM LPM	Nominal Flow GPM LPM	Maximum Flow GPM LPM
2½ 65	2.875 73.0	1.40 5.30	92.0 348.2	290.0 1097.7	1.40 5.30	92.0 348.2	290.0 1097.7
3 80	3.500 88.9	1.50 5.68	130.0 492.1	410.0 1551.9	1.50 5.68	130.0 492.1	410.0 1551.9
4 100	4.500 114.3	1.90 7.19	200.0 757.0	650.0 2460.3	1.90 7.19	200.0 757.0	650.0 2460.3
5 125	5.563 141.3	4.20 15.90	320.0 1211.2	1020.0 3860.7	4.20 15.90	320.0 1211.2	1020.0 3860.7
6 150	6.625 168.3	5.00 18.93	450.0 1703.3	1430.0 5412.6	5.00 18.93	450.0 1703.3	1430.0 5412.6
8 200	8.625 219.1	30.00 113.55	820.0 3103.7	2600.0 9841.0	30.00 113.55	820.0 3103.7	2600.0 9841.0
10 250	10.750 273.0	70.00 264.95	1280.0 4844.4	4040.0 15291.4	70.00 264.95	1280.0 4844.4	4040.0 15291.4
12 300	12.750 323.9	115.00 435.28	1550.0 5866.8	4950.0 18735.8	115.00 435.28	1550.0 5866.8	4950.0 18735.8

IMPORTANT NOTES: (SEE PG. 3-16 FOR MEASURING ACCURACY)

Balancing valves should be sized in relation to the GPM flows (and not in relation to pipeline size). The Minimum Flow is calculated from the minimum open setting of the valve and a minimum pressure drop 1 Ft. WG (= 3 kPa). The Nominal Flow is calculated from the maximum open setting of the valve and the minimum recommended pressure drop, 2 Ft. WG (= 6 kPa). The Maximum Flow is calculated from the maximum open setting of the valve and the maximum pressure drop, 20 Ft. WG (= 60 kPa). A computer program, TA-Select, is available from Tour & Andersson for calculation of pre-setting values and other applications.

Balancing Valve

SERIES 78U

For Complete Information,
 Request Publication **08.16**.

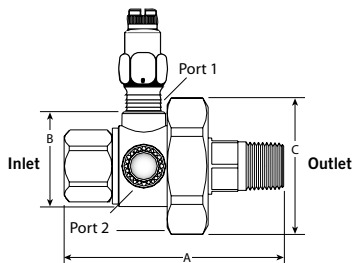

The Series 78U Union Port Fitting provides a simplified, quality terminal hookup for installation at coil outlet. The Series 78U features a port section equipped standard with a manual air vent port on top allowing for optimal positioning at coil outlet and effective venting together with a pressure/temperature port on the side. The Series 78U is equipped with an EPDM o-ring.

Rated up to 400 psi/2758 kPa and 250°F/121°C.

Inlet Nominal Size Inches/mm		Outlet Nominal Size Inches/mm		Size			Approx. Weight Each Lbs. kg
A	B	A	B	A	B	C	
½	x	½	15	3.5 89	0.8 19	1.6 39	0.6 0.28
¾	x	½	15	3.7 94	0.9 23	2.2 56	1.0 0.45
20		¾	20	3.58 90	1.43 36	1.80 46	0.95 0.40
1	x	¾	20	4.1 104	1.0 25	2.4 60	1.2 0.56
25		1	25	3.65 93	1.66 42	2.13 54	1.2 0.50
1¼	x	1	25	4.3 109	1.2 30	2.9 74	2.8 1.28
32		1¼	32	4.24 108	2.08 53	2.58 66	2.1 1.00
1½	x	1¼	32	4.4 112	1.3 32	3.5 88	3.5 1.57
40		1½	40	4.39 112	2.26 57	3.21 82	2.9 1.30
2	x	1½	40	4.6 116	1.7 43	3.9 99	5.9 2.66
50		2	50	4.6 116	2.56 65	3.54 90	3.9 1.70

NOTES

Dimensions based on F x M connections and will vary with mixed connections.
 All weights and dimensions are subject to minor changes.

Valves – Circuit Balancing Valves

Y-Strainer/Ball Valve Combination

SERIES 78Y

For Complete Information,
Request Publication **08.16.**

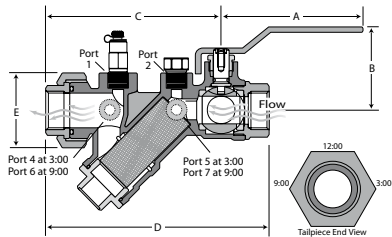

The Series 78Y Y-Strainer/Ball Valve Combination provides a simplified, quality terminal hookup that protects both coil and modulating valve from pipe scale, sand or weld slag. The Series 78Y features a 20 grid stainless steel strainer (removable without breaking the line), a blow-out proof valve stem, Teflon® packing, plated ball and a strainer-blowdown & drain valve with hose thread, cap & retainer. Equipped standard with a pressure/temperature port and extra plugged port on top with a union end. End connections are female thread by female thread or sweat by sweat.

2Rated up to 400psi/2758kPa and 250°F/121°C.

Inches mm	Size						Approx. Weight Each Lbs. kg	C _v /K _v
	A Inches mm	B Inches mm	C Inches mm	D Inches mm	E Inches mm	F Inches mm		
½ 15	3.9 99	2.0 51	4.8 122	6.2 157	2.1 53	2.1 53	2.0 0.91	7.8 6.7
¾ 20	3.9 99	2.0 51	4.8 122	6.2 157	2.1 53	2.1 53	2.0 0.95	8.8 7.6
¾ x ½ 20 15	4.03 102	2.00 51	4.87 124	6.72 171	1.80 46	-	2.71 1.2	-
1 25	3.9 99	2.0 51	4.8 122	6.2 157	2.1 53	2.1 53	2.0 0.95	8.8 7.6
1* 25	4.7 119	2.6 66	6.8 173	8.6 218	2.8 71	2.4 61	4.5 2.04	19.7 17.0
1 x ¾ 25 20	4.70 119	2.60 66	7.50 191	10.30 262	2.58 66	-	5.7 2.6	-
1¼ 32	4.7 119	2.6 66	6.8 173	8.6 218	2.8 71	2.4 61	4.6 2.09	20.4 17.6
1¼* 32	4.7 119	2.6 66	6.8 173	8.6 218	2.8 71	2.4 61	4.6 2.09	20.4 17.6
1¼ x 1 32 25	4.70 119	2.60 66	6.69 170	9.60 244	2.58 66	-	5.7 2.6	-
1½ 40	5.5 140	3.5 89	7.9 201	10.0 254	3.8 97	2.5 64	9.3 4.22	52.7 45.4
2 50	5.5 140	3.5 89	7.9 201	10.0 254	3.8 97	2.5 64	9.5 4.31	55.1 47.5

NOTES

Weights based on F x F connections and will vary with mixed options/connections.

Weights and dimensions are subject to minor changes.

* Denotes female thread not available on union end.

Differential Pressure Controller

TA SERIES 793

Threaded End

For Complete Information,
Request Publication **08.29.**

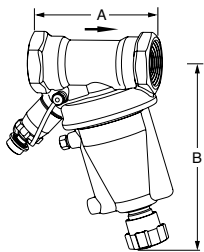

TA Differential Pressure Controllers come standard with a drain kit, measuring port, transition nipple and adjusting tool.

End connection on ½"/15 mm to 2"/50 mm sizes are all female IPS thread only. Sweat is not available.

Nominal Size Inches mm	Actual Outside Dia. Inches mm	Differential Pressure Range psi/kPa	A End to End Inches mm	B Center to Top Inches mm	Approx. Weight Each Lbs. kg
½ 15	0.840 21.3	1.45-8.70 10-60	3.31 84	5.39 137	2.4 1.1
¾ 20	1.050 26.7	1.45-8.70 10-60	3.58 91	5.47 139	2.6 1.2
1 25	1.315 33.7	1.45-8.70 10-60	3.66 93	5.55 141	2.9 1.3
1¼ 32	1.660 42.4	2.90-11.6 20-80	5.24 133	7.05 179	5.7 2.6
1½ 40	1.900 48.3	2.90-11.6 20-80	5.32 135	7.13 181	6.4 2.9
2 50	2.375 60.3	2.90-11.6 20-80	5.39 137	7.36 187	7.7 3.5

Valves – Circuit Balancing Valves

VALVE SELECTION GUIDE TA SERIES 793

English Measurements in Pounds per Square Inch and Gallons per Minute

Size	Dp _L (psi)																	
	1.5			2.9			4.4			5.8			7.3			8.7		
Inches	Q _{min}	Q _{nom}	Q _{max}	Q _{min}	Q _{nom}	Q _{max}	Q _{min}	Q _{nom}	Q _{max}	Q _{min}	Q _{nom}	Q _{max}	Q _{min}	Q _{nom}	Q _{max}	Q _{min}	Q _{nom}	Q _{max}
½	0.1	1.4	2.0	0.1	2.0	2.7	0.2	2.4	3.4	0.2	2.8	3.9	0.2	3.1	4.3	0.2	3.4	4.7
¾	0.2	3.1	4.3	0.3	4.3	6.0	0.4	5.3	7.4	0.4	6.1	8.6	0.5	6.8	9.6	0.5	7.4	10.5
1	0.4	5.3	7.7	0.5	7.4	10.7	0.7	9.1	13.2	0.8	10.5	15.2	0.9	11.8	17.0	0.9	12.8	18.6

Size	Dp _L (psi)																			
	2.9			4.4			5.8			7.3			8.7			10.2			11.6	
Inches	Q _{min}	Q _{nom}	Q _{max}	Q _{min}	Q _{nom}	Q _{max}	Q _{min}	Q _{nom}	Q _{max}	Q _{min}	Q _{nom}	Q _{max}	Q _{min}	Q _{nom}	Q _{max}	Q _{min}	Q _{nom}	Q _{max}		
1½	0.8	11.7	16.6	1.0	14.4	20.4	1.2	16.6	23.5	1.3	18.6	26.3	1.4	20.3	28.7	1.5	22.0	31.1		
1½	1.2	17.6	25.0	1.5	21.6	30.8	1.8	24.8	35.3	2.0	27.9	39.6	2.2	30.4	43.3	2.3	32.9	46.8		
2	2.3	33.2	47.6	2.9	40.9	58.6	3.3	46.9	67.3	3.7	52.6	75.5	4.1	57.4	82.4	4.4	62.2	89.3		

Differential Pressure Controller

TA SERIES 794 Flanged End

For Complete Information, Request Publication **08.29**.

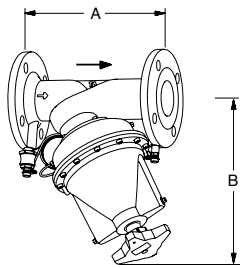

TA Pressure Differential Controllers come standard with a drain kit, measuring port, transition nipple and adjusting tool. End connections are ANSI flanges only, grooved ends are not available.

Nominal Size Inches mm	Actual Outside Dia. Inches mm	Differential Pressure Range psi/kPa	A End to End Inches mm	B Center to Top Inches mm	Approx. Weight Each Lbs. kg
2½ 65	2.875 73.0	2.90-11.6 20-80	11.42 290	16.3 414	46.3 21
3 80	3.500 88.9	2.90-11.6 20-80	12.21 310	17.17 436	52.9 24
4 100	4.500 114.3	2.90-11.6 20-80	13.78 350	18.11 460	72.8 33

VALVE SELECTION GUIDE

English Measurements in Pounds per Square Inch and Gallons per Minute (Spring Option 1)

Size	Dp _L (psi)																			
	2.9			4.4			5.8			7.3			8.7			10.2			11.6	
Inches	Q _{min}	Q _{nom}	Q _{max}	Q _{min}	Q _{nom}	Q _{max}	Q _{min}	Q _{nom}	Q _{max}	Q _{min}	Q _{nom}	Q _{max}	Q _{min}	Q _{nom}	Q _{max}	Q _{min}	Q _{nom}	Q _{max}		
2½	2.7	48.8	70.2	3.4	60.1	86.5	3.9	69.0	99.3	4.3	77.4	111.4	4.7	84.5	121.6	5.1	91.5	131.7		
3	4.3	74.1	107.3	5.3	91.3	132.2	6.1	104.8	151.7	6.8	117.6	170.2	7.4	128.4	185.9	8.0	139.0	201.2		
4	8.6	150.2	214.6	10.6	185.0	264.3	12.1	212.4	303.5	13.6	238.3	340.5	14.9	260.2	371.7	16.1	281.7	402.5		

English Measurements in Pounds per Square Inch and Gallons per Minute (Spring Option 2)

Size	Dp _L (psi)																			
	5.8			7.3			8.7			10.2			11.6			13.1			14.5	
Inches	Q _{min}	Q _{nom}	Q _{max}	Q _{min}	Q _{nom}	Q _{max}	Q _{min}	Q _{nom}	Q _{max}	Q _{min}	Q _{nom}	Q _{max}	Q _{min}	Q _{nom}	Q _{max}	Q _{min}	Q _{nom}	Q _{max}		
2½	3.9	69.0	99.3	4.3	77.4	111.4	4.7	84.5	121.6	5.1	91.5	131.7	5.5	97.5	140.5	5.8	103.7	149.3		
3	6.1	104.8	151.7	6.8	117.6	170.2	7.4	128.4	185.9	8.0	139.0	201.2	8.6	148.3	214.6	9.1	157.6	228.1		
4	12.1	212.4	303.5	13.6	238.3	340.5	14.9	260.2	371.7	16.1	281.7	402.5	17.2	300.4	429.2	18.2	319.3	456.1		

Size	Dp _L (psi)																	
	16.0			17.4			18.9			20.3			21.8			23.2		
Inches	Q _{min}	Q _{nom}	Q _{max}	Q _{min}	Q _{nom}	Q _{max}	Q _{min}	Q _{nom}	Q _{max}	Q _{min}	Q _{nom}	Q _{max}	Q _{min}	Q _{nom}	Q _{max}	Q _{min}	Q _{nom}	Q _{max}
2½	6.4	114.6	165.0	6.7	119.5	172.0	7.0	124.5	179.3	7.2	129.0	185.8	7.5	133.7	192.6	7.7	138.0	198.6
3	10.1	174.1	252.0	10.5	181.6	262.8	11.0	189.3	273.9	11.4	196.1	283.9	11.8	203.3	294.2	12.1	209.7	303.5
4	20.2	352.9	504.1	21.0	368.0	525.7	21.9	383.5	547.9	22.7	397.4	567.8	23.5	411.9	588.4	24.3	424.9	607.0

Valves



Hand-held Circuit Balancing Instrument

TA SERIES 737

For Complete Information
Request Publication **08.16**

- Series 737 CBI-II meter is a hand-held computer balancing instrument programmed for use with Tour & Andersson balancing valves to obtain direct reading of flow and differential pressures
- This instrument consists of an electronic differential pressure gauge and a microcomputer
- Measured values can be saved in the unit before transferring the information to a PC for printing out a commissioning report or for creating a permanent record



Link Differential Pressure Sensor

TA SERIES 736

For Complete Information
Request Publication **08.16**

- Provides connection between a building's heating and cooling circuits and building's monitoring system (BMS)
- Continuously measures the flow and differential pressure through and across the TA balancing valves
- Measurement probes provided for direct connection to the measurement points on all TA Series 786, 787, 788, and 789 circuit balancing valves



Portable Differential Pressure Meter

TA SERIES 738 Flanged End (250psi/1720kPa)

For Complete Information
Request Publication **08.16**

- TA Series 738 portable differential pressure meter is an accurate device for measuring differential pressure in Tour & Andersson circuit balancing valves
- Using the balancing wheel supplied with the meter, the measured pressure differential can be converted to a flow measurement
- TA Series 738 can be used on systems up to the full rated working pressure of the Tour & Andersson valves (or up to 500 psi/3450 kPa on other devices)
- Units are supplied in a protective case including a balancing wheel, adapter fittings and valve
- When using the portable differential pressure meter on other valves, contact Victaulic

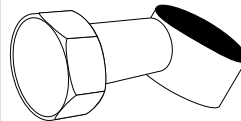

Drain Kit

TA SERIES 786-DK

For Complete Information
Request Publication **08.16**

- A separate drain kit with a $\frac{3}{4}$ "/20mm connection is available for Series 786 and Series 787 valves
- Kit must be field mounted

Valves



TA Select III Computer Program

TA Select III helps you choose the right balancing valve, taking the desired flow rate and pressure drop into consideration. The software will advise the correct combination of valve, handwheel position and pipe size to correctly balance the system. A sophisticated viscosity correction procedure displays the density, viscosity, specific heat and freezing point of fluids such as glycols and brines. It also shows the true value of flows in the valves.

The program will also size the pipe, generate Cv values for the ATC valves and give pre-set information for all the TA valves on the project.



CMI Pressure Differential Meter

TA SERIES 73M

TA CMI is a computer programmed measuring instrument. It is a handheld instrument for measuring differential pressure, temperature and flow through balancing valves in hydronic systems. It consists of a sensor unit and an instrument unit that has been programmed with the TA valve characteristics, which makes it possible to take a direct reading of flow differential pressures.

Accessories

- Victaulic offers a complete line of accessories for equipment protection, special applications and flow measurement
- The Victaulic line of suction diffusers and strainers reduces maintenance downtime and allows easy access to the system
- Victaulic expansion joints accommodate expansion and contraction to meet system requirements
- To ensure system flow requirements are being met, Victaulic offers a line of flow measuring devices that are easy to install and simple to use

Advanced Groove System **AGS™**



For 14–24"/350–600mm piping systems
Victaulic offers Advanced Groove System (AGS) products, see pg. 5-1.

Suction Diffuser

SERIES 731-I, PG. 4-3
AGS SERIES W731-I, PG. 5-15



Vic-Strainer® – Tee Type

SERIES 730, PG. 4-5
AGS SERIES W730, PG. 5-16



Vic-Strainer – Wye Type

SERIES 732, PG. 4-6
AGS SERIES W732, PG. 5-17



Mover® Expansion Joint

STYLE 150, PG. 4-7



Standard Expansion Joint

STYLE 155, PG. 4-8,
AGS SERIES W155, PG. 5-4



Dielectric Waterway Fitting

STYLE 47, PG. 4-9



Accessories

Faster, easier maintenance

Victaulic grooved accessories allow fast, easy maintenance of the system by reducing down time. Simply remove one nut and bolt, then the closure cap and basket. In a matter of minutes the basket can be cleaned and reinstalled so the system is quickly back in service.



Remove one nut and bolt to access the system



Remove coupling and closure cap



Remove basket, clean, then reinstall

NOTE:

Always read and understand operating instructions before attempting installation or system maintenance.

WARNING:

Depressurize and drain the piping system before attempting to install, remove, or adjust any Victaulic piping products.

PRODUCTS

- 1-1 Couplings
- 2-1 Fittings
- 3-1 Valves
- 4-1 Accessories**
- 5-1 Advanced Groove System
- 6-1 Hole Cut Piping System
- 7-1 Plain End Piping System
- 8-1 Grooved System for Stainless Steel Pipe
- 9-1 Pressfit System for Stainless Steel Pipe
- 10-1 Plain End Piping System for HDPE Pipe
- 11-1 Grooved Copper
- 12-1 PermaLynx System for Copper Tube
- 13-1 Grooved AWWA Ductile Iron Pipe
- 14-1 Victaulic Depend-O-Lok® System
- 15-1 Aquamine Reusable PVC Products
- 16-1 Gaskets
- 17-1 Pipe Preparation Tools
- 18-1 Product Index
- 19-1 Piping Software

Accessories

Suction Diffuser

SERIES 731-I

For Complete Information
Request Publication **09.71**

ACCESSORIES



- Provides optimum flow conditions at the inlet side of the pump
- Equipped with a removable strainer and fine mesh sleeve
- Pipe support bosses provided to aid in proper alignment
- Plug is provided to allow easy draining of the system
- Simple removal of closure coupling speeds cleaning and maintenance
- Pressure rated up to 300 psi/2065 kPa
- Sizes from 2"/60.3mm x 76.1 mm through 12 x 12"/300 x 300mm

Size		Dimensions Inches/mm									Approx. Wgt. Each
System Side (inlet)	System Side (outlet)	C-E1	C-E2 †	CLR	C-O	D	L	OAL	OAW	Lbs. kg	
Inches	mm										
76.1mm	2 × 60.3	-	6.81 173	12.0 305	6.81 173	1.01 26	3.32 84	12.25 311	6.75 171	23.0 10.4	
3 88.9	2 × 60.3	4.25 108	-	12.0 305	6.81 173	1.01 26	3.32 84	12.25 311	6.75 171	18.0 8.2	
	2 1/2 × 73	4.25 108	-	12.0 305	6.81 173	1.01 26	3.32 84	12.25 311	6.75 172	22.0 10.0	
	76.1 mm	4.25 108	-	12.0 305	6.81 173	1.01 26	3.32 84	12.25 311	8.20 208	20.0 9.1	
	3 × 88.9	-	8.13 207	14.0 356	8.13 207	1.34 34	3.97 101	14.50 368	8.29 211	39.0 17.7	
4 114.3	2 × 60.3	-	7.31 186	12.0 305	6.81 173	1.01 26	3.32 84	12.25 311	6.75 171	25.0 11.3	
	2 1/2 × 73	-	7.31 186	12.0 305	6.81 173	1.01 26	3.32 84	12.25 311	7.87 200	28.0 12.7	
	76.1 mm	-	7.31 186	12.0 305	6.81 173	1.01 26	3.32 84	12.25 311	8.20 208	26.0 11.8	
	3 × 88.9	5.00 127	-	14.0 356	8.13 207	1.34 34	3.97 101	14.50 368	8.29 211	34.0 15.4	
	4 × 114.3	-	9.13 232	16.0 406	9.13 232	1.87 48	4.75 121	16.00 406	9.87 251	61.0 27.7	
139.7	76.1 ×	-	8.81 224	12.0 305	6.81 173	1.01 26	3.32 84	12.25 311	8.20 208	27.0 12.2	
	3 × 88.9	-	9.63 245	14.0 356	8.13 207	1.34 34	3.97 101	14.50 368	8.29 211	43.0 19.5	
	4 × 114.3	5.50 140	-	16.0 406	9.13 232	1.87 48	4.71 120	16.00 406	9.87 251	51.0 23.1	
	139.7 ×	-	10.63 270	18.0 457	10.63 257	2.36 60	5.25 133	18.00 457	10.78 274	80.0 36.3	
5	3 × 88.9	-	8.63 219	14.0 356	8.13 207	1.34 34	3.97 101	14.50 368	8.29 211	43.0 19.5	
	4 × 114.3	5.50 140	-	16.0 406	9.13 232	1.87 48	4.75 121	16.00 406	9.87 251	50.0 22.7	
	5 × 141.3	-	10.63 270	18.0 475	10.63 270	2.36 60	5.25 133	18.50 470	10.90 277	80.0 36.3	

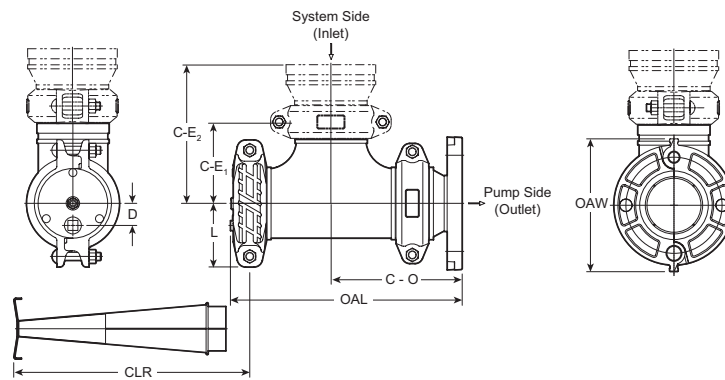

Accessories

Suction Diffuser

SERIES 731-I

For Complete Information
Request Publication **09.71**



- Provides optimum flow conditions at the inlet side of the pump
- Equipped with a removable strainer and fine mesh sleeve
- Pipe support bosses provided to aid in proper alignment
- Plug is provided to allow easy draining of the system
- Simple removal of closure coupling speeds cleaning and maintenance
- Pressure rated up to 300 psi/2065 kPa
- Sizes from 2"/60.3mm x 76.1 mm through 12x12"/300x300mm

Size		Dimensions Inches/mm								Approx. Wgt. Each	
System Side (inlet)	× System Side (outlet)										
Inches		C-E1	C-E2 †	CLR	C-O	D	L	OAL	OAW	Lbs. kg	
mm											
165.1	× 3	–	9.13	14.0	8.13	1.34	3.97	14.50	8.30	46.0	
		88.9	232	356	207	34	101	368	211	20.9	
		4	9.63	16.0	9.13	1.87	4.75	16.00	9.87	64.0	
		114.3	245	406	232	48	121	406	251	29.0	
		139.7	6.50	–	18.0	2.36	5.25	18.50	10.78	64.0	
		165	–	457	10.63	60	133	470	274	29.0	
6 168.3	× 3	–	9.13	14.0	8.13	1.34	3.97	14.50	8.29	46.0	
		88.9	232	356	207	34	101	368	211	20.9	
		4	9.63	16.0	9.13	1.87	4.75	16.00	9.87	63.0	
		114.3	245	406	232	48	121	406	251	28.6	
			139.7	6.50	–	18.0	2.36	5.25	18.50	10.78	66.0
			165	–	475	10.63	60	133	470	274	29.9
		5	6.50	–	18.0	2.36	5.25	18.50	10.90	66.0	
		141.3	165	–	475	10.63	60	470	277	29.9	
		6	–	12.88	22.0	3.27	6.60	22.25	11.90	142.0	
		168.3	–	327	559	83	168	565	302	64.4	
8	× 139.7	–	11.63	18.0	10.63	2.36	5.25	18.50	10.78	86.0	
		–	295	475	270	60	133	470	274	39.0	
		5	–	11.63	18.0	10.63	2.36	5.25	18.50	10.90	86.0
		141.3	–	295	475	270	60	133	470	277	39.0
			165.1	7.75	–	22.0	3.27	6.60	22.25	11.92	116.0
			197	–	559	327	83	168	565	303	52.6
		6	7.75	–	22.0	3.27	6.60	22.25	11.90	116.0	
		168.3	197	–	559	83	168	565	302	52.6	
		8	–	15.13	25.0	4.23	7.96	26.00	14.50	280.0	
		219.1	–	384	635	107	202	656	368	127.0	
10 273.0	× 165.1	–	13.88	22.0	12.88	3.27	6.60	22.25	11.92	152.0	
		–	353	559	327	83	168	565	302	69.0	
			6	–	13.88	22.0	3.27	6.60	22.25	11.90	152.0
			168.3	–	353	559	83	168	565	302	69.0
			8	9.00	–	25.0	4.23	7.96	26.00	14.50	224.0
		219.1	229	–	635	107	202	656	368	101.6	
		10	–	17.13	28.0	5.32	8.93	29.00	17.25	373.0	
		273.0	–	435	711	135	227	737	432	169.2	
12 323.9	× 8	–	16.13	25.0	15.13	4.23	7.96	26.00	14.50	316.0	
		219.1	–	410	635	107	202	656	368	143.3	
		10	10.00	–	28.0	17.13	5.32	8.93	29.00	17.25	303.0
		273.0	254	–	711	135	227	737	432	183.3	
		12	–	24.13	35.0	5.88	9.95	37.5	20.25	561.0	
		323.9	–	613	889	613	149	953	514	254.5	
14 – 24 350 – 600		AGS™ See AGS Series W731-I, pg.5-15.									

Accessories

Vic-Strainer – Tee Type

SERIES 730

For Complete Information
Request Publication 09.02



ACCESSORIES

- Series 730 Vic-Strainer is lighter than flanged "Y" type strainers and provides straight-through flow for lower pressure drop
- The Series 730 Vic-Strainer installs with two Victaulic couplings, and is rated up to 300psi/2065 kPa
- A durable type 304 stainless steel screen is provided. The standard mesh sizes are 12 mesh for sizes 1½–3"/40–80mm; 6 mesh for sizes 4–12"/100–300mm; other smaller sizes available

Size		Max. Work Pressure † psi kPa	Dimensions					Approx. Wgt. Each Lbs. kg	Flow Coefficient@ (Fully Open) C _v Values K _v Values
Nominal Size Inches mm	Actual Outside Diameter Inches mm		A Inches mm	B Inches mm	X Inches mm	Y Inches mm	H Inches mm		
1½ 40	1.900 48.3	750 5175	5.50 140	3.75 95	2.94 75	5.81 148	0.25 6	7.0 3.2	61 52.8
2 50	2.375 60.3	750 5175	6.50 165	4.25 108	3.35 85	5.78 147	0.50 13	5.8 2.6	190 164.4
2½ 65	2.875 73.0	750 5175	7.50 191	4.75 121	3.88 98	6.38 162	0.50 13	8.9 4.0	230 199.0
3 80	3.500 88.9	750 5175	8.50 216	5.25 133	4.54 115	6.81 173	0.75 19	21.0 9.5	290 250.9
4 100	4.500 114.3	750 5175	10.00 254	6.00 152	5.83 148	8.21 209	1.00 25	19.6 8.9	425 367.6
5 125	5.563 141.3	750 5175	11.00 279	6.50 165	7.03 179	9.89 251	1.25 32	31.3 14.2	685 592.5
6 150	6.625 168.3	700 4825	13.00 330	7.50 191	8.26 210	10.83 275	1.25 32	43.3 19.6	950 821.8
8 200	8.625 219.1	600 4130	15.50 394	9.00 229	10.54 268	13.74 349	2.00 51	75.0 34.0	2108 1823.4
10 250	10.750 273.0	500 3450	18.00 457	10.25 260	12.86 327	16.98 431	2.00 51	136.0 61.7	2683 2320.8
12 300	12.750 323.9	400 2750	20.00 508	11.25 286	14.86 377	18.88 480	2.00 51	197.2 89.4	3872 3349.3
14 – 24 350 – 600	AGS™ See AGS Series W730, pg. 5-16.								

† Working pressure is maximum based on Style 07 access coupling and will be governed by couplings used for installation and related system components. Maximum differential pressure from inlet to outlet must not exceed 10psi/69kPa.

@ C_v/K_v values for flow of water at +60°F/+16°C.

IMPORTANT NOTE:

For 20–30"/500–750mm sizes contact Victaulic.

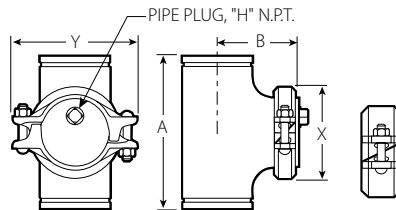

TYPICAL FOR ALL SIZES

Accessories

Vic-Strainer – Wye Type

SERIES 732

For Complete Information
Request Publication 09.03



- Provides straight through flow for lower pressure drop
- Installs with two Victaulic couplings
- Durable type 304 stainless steel perforated basket
- Pressure rated up to 300 psi/2065 kPa
- Sizes from 2–12"/50–300 mm

Size		Max. Work Press.†	Dimensions								Approx. Wgt. Each	Flow Coefficient@ C _v Values K _v Values
Nominal Size Inches mm	Actual Outside Diameter Inches mm		psi kPa	A End to End Inches mm	B Inches mm	C Inches mm	D Inches mm	E Inches mm	F Inches mm	G* Inches mm		
2	2.375	300	9.75	7.00	2.75	7.54	8.54	3.50	5.25	0.50	10.0	72
50	60.3	2065	248	178	70	192	217	89	133	13	4.5	62.3
2½	2.875	300	10.75	7.75	3.00	8.32	9.32	4.13	5.81	0.50	14.0	111
65	73.0	2065	273	197	76	211	237	105	148	13	6.4	96.0
76.1 mm	3.000	300	10.75	7.75	3.00	8.32	9.32	4.13	5.81	0.50	14.0	111
	76.1	2065	273	197	76	211	237	105	148	13	6.4	96.0
3	3.500	300	11.75	8.50	3.25	9.08	10.14	4.75	6.63	0.75	20.0	164
80	88.9	2065	299	216	83	231	258	121	168	19	9.1	141.9
4	4.500	300	14.25	10.50	3.75	11.06	12.36	6.25	7.94	1.00	32.0	285
100	114.3	2065	362	267	95	281	314	159	202	25	14.5	246.5
5	5.563	300	16.50	12.50	4.00	13.00	14.36	7.88	9.50	1.00	50.0	410
125	141.3	2065	419	318	102	330	365	200	241	25	22.7	354.7
139.7 mm	5.500	300	16.50	12.50	4.00	13.00	14.36	7.88	9.50	1.00	50.0	410
	139.7	2065	419	318	102	330	365	200	241	25	22.7	354.7
6	6.625	300	18.50	14.00	4.50	14.44	16.06	9.25	10.50	1.25	72.0	597
150	168.3	2065	470	356	114	367	408	235	267	32	32.7	516.4
165.1 mm	6.500	300	18.50	14.00	4.50	14.44	16.06	9.25	10.50	1.25	72.0	597
	165.1	2065	470	356	114	367	408	235	267	32	32.7	516.4
8	8.625	300	24.00	18.00	6.00	18.38	20.50	12.38	13.19	1.50	125.0	1000
200	219.1	2065	610	457	152	467	521	315	335	38	56.7	865.0
10	10.750	300	27.00	21.00	6.00	22.00	23.82	14.25	15.92	2.00	205.0	1800
250	273.0	2065	686	533	152	559	605	362	404	51	93.0	1557.0
12	12.750	300	30.00	24.50	5.50	24.75	27.37	17.00	18.23	2.00	280.0	2800
300	323.9	2065	762	622	140	629	695	432	463	51	127.0	2422.2
14 – 24 350 – 600			 See AGS Series W732, pg. 5-17.									

† Working pressure is maximum and will be governed by couplings used for installation and related system components. Maximum differential pressure from inlet to outlet must not exceed 10psi/69kPa.

* Dimensions will vary depending upon coupling orientation.

@ C_v/K_v values for flow of water at +60°F/+16°C.

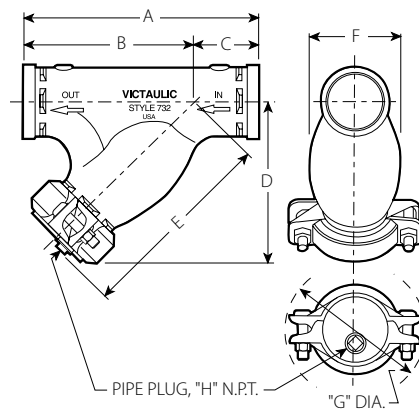

TYPICAL FOR ALL SIZES

Accessories

Mover Expansion Joint

STYLE 150

For Complete Information
Request Publication 09.04



Size		Max. Work Pressure psi kPa	Maximum Available Movement Inches mm	Dimensions			Length Z		Approx. Wgt. Each Lbs. kg
Nominal Size Inches mm	Actual Outside Diameter Inches mm			X Height Inches mm	Y Width Inches mm	Minimum Inches mm	Maximum Inches mm		
2 50	2.375 60.3	350 2410	3.00 76.2	3.38 86	5.50 139	11.88 302	14.88 378	15.9 7.2	
76.1 mm	3.000 76.1	350 2410	3.00 76.2	4.38 111	6.75 171	12.13 308	15.13 384	38.0 17.2	
3 80	3.500 88.9	350 2410	3.00 76.2	4.75 121	7.25 184	12.13 308	15.13 384	25.6 11.6	
4 100	4.500 114.3	350 2410	3.00 76.2	6.25 159	9.00 229	14.13 359	17.13 435	39.6 18.0	
5 125	5.563 141.3	350 2410	3.00 76.2	7.12 181	10.75 273	14.13 359	17.13 435	55.0 24.9	
139.7 mm	5.500 139.7	350 2410	3.00 76.2	6.25 159	9.00 229	14.13 359	17.13 435	56.0 25.4	
6 150	6.625 168.3	350 2410	3.00 76.2	8.63 219	12.00 305	16.00 406	19.00 483	75.0 34.0	
165.1 mm	6.500 165.1	350 2410	3.00 76.2	8.63 219	12.00 305	16.00 406	19.00 483	75.0 34.0	

- Slip-type expansion joint
- Up to 3/80mm axial end movement
- Permits easy adjustments prior to installation to accommodate expansion, contraction or both
- Service up to +230°F/+110°C
- Pressure rated up to 350psi/2400kPa depending on type of coupling installed
- Sizes from 2-6"/50-150mm

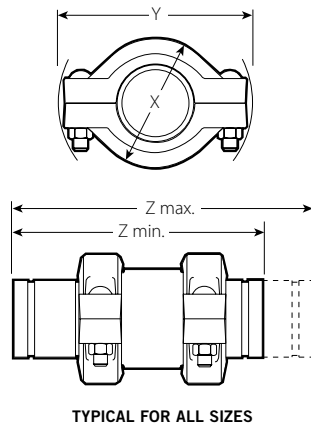

Expansion Joint Installation

For Complete Information Request Publication 09.06

For proper expansion joint operation, the piping system must be sectioned into individual straight pipe runs with suitable anchor installations. Within each pipe section, properly spaced alignment guides and weight support devices are also necessary to permit free axial pipe movement. Refer to installation instructions supplied with each unit.

Whenever possible, the expansion joint should be located adjacent to an anchor within four (4) pipe diameters. The first and second alignment guides on the opposite side of the expansion joint should be located at maximum distances of four (4) and fourteen (14) pipe diameters, respectively. Additional intermediate guides should be placed. If expansion joint cannot be located adjacent to an anchor, install guides on both sides of the unit.

In addition, where long length, low pressure applications may require few intermediate alignment guides, the pipe weight, including any liquid contents, must be adequately supported. (For recommended spacing for a water system request publication 26.01)

When installed the expansion joint can provide compensation for 3/80mm of axial pipe movement. Expansion joint may be set to compensate for pipe expansion, contraction, or some combination. The movement caused by installation at a temperature other than the minimum or maximum operation temperature should also be accounted for. Refer to installation instructions supplied with each unit, or contact Victaulic for recommendations.

Accessories

Standard Expansion Joint

STYLE 155

For Complete Information Request Publication **09.05**



The ties holding the couplings in position must be removed after installation

- Combination of couplings and short nipples joined in tandem
- May be used as flexible connectors; but they will not simultaneously provide full expansion and full deflection
- Joints installed horizontally require independent support to prevent deflection, that will reduce available expansion
- Sizes from ¾ – 12"/20 – 300 mm

Standard Units †								
Size		Style	Dimensions				Approx. Wgt. Each	
Nominal Size Inches mm	Actual Outside Diameter Inches mm	Coupling Style	L - Length (ref.) §		X Height Inches mm	Y Width Inches mm	Total Movement Capability Inches mm	Lbs. kg
			Compressed Inches mm	Expanded Inches mm				
¾ 20	1.050 26.7	77	26.25 667	28.13 715	2.13 54	3.63 92	1.88 48	17.0 7.7
1 25	1.315 33.7	77	26.25 667	28.13 715	2.38 61	3.88 99	1.88 48	20.0 9.1
1¼ 32	1.660 42.4	77	28.25 718	30.13 765	2.63 67	4.63 118	1.88 48	28.0 12.7
1½ 40	1.900 48.3	77	28.25 718	30.13 765	3.00 76	5.00 127	1.88 48	31.0 14.1
2 50	2.375 60.3	75	28.25 718	30.13 765	3.50 89	5.13 130	1.88 48	27.0 12.2
2½ 65	2.875 73.0	75	28.25 718	30.13 765	4.00 102	5.88 149	1.88 48	36.0 16.3
3 80	3.500 88.9	75	28.25 718	30.13 765	4.63 118	6.75 172	1.88 48	46.0 20.9
3½ 90	4.000 101.6	75	28.25 718	30.13 765	5.25 133	7.38 188	1.88 48	54.0 24.5
4 100	4.500 114.3	75	26.25 667	28.00 711	5.88 149	8.00 203	1.75 45	54.0 24.5
5 125	5.563 141.3	75	26.25 667	28.00 711	7.00 178	10.18 259	1.75 45	72.0 32.7
6 150	6.625 168.3	75	26.25 667	28.00 711	8.13 207	11.00 279	1.75 45	90.0 40.8
8 200	8.625 219.1	75	28.50 724	30.25 768	10.38 264	14.00 356	1.75 45	150.0 68.0
10 250	10.750 273.0	77	32.50 826	34.25 870	13.50 343	16.75 426	1.75 45	320.0 145.2
12 300	12.750 323.9	77	32.50 826	34.25 870	15.50 394	19.00 483	1.75 45	373.0 169.2
14 – 24 350 – 600		AGS™	See AGS Series W155, pg.5-4.					

† Contact Victaulic for performance requirements not listed above.

§ Dimensions may vary slightly due to tolerances.

IMPORTANT NOTE:

For Performance Data refer to 06.05 for Style 75 and 06.04 for Style 77.

14 – 24"/350 – 600 mm sizes available in the Advanced Grooved System. Contact Victaulic for details.

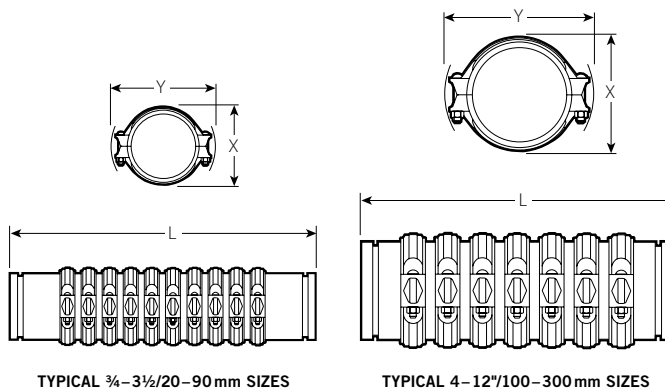

Accessories

Dielectric Waterway Fitting

STYLE 47

For Complete Information
Request Publication **09.07**



- Clearflow* dielectric waterway fittings utilize an inert non-corrosive thermoplastic lining that is NSF/FDA listed
 - The thermoplastic lining insulates the inside of the waterway thereby inhibiting formation of local galvanic cell corrosion that occurs between dissimilar metals in the presence of water
 - Designed for continuous use at temperatures up to +230°F/+110°C
 - Style 47-GT (grv. x thd.) and TT (thd. x thd.) NSF Listed in accordance with ANSI/NSF 61 for up to 180°F/82°C potable water service
 - Pressure rated up to 300psi/2065kPa
 - Sizes from ½–8"/15–200 mm
- * ClearFlow is a registered trademark of Perfection Corp.

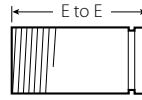

STYLE 47-GT
GRV. x THD.

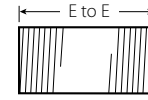

STYLE 47-TT
THD. x THD.

Size		Style 47-GT Grooved x Threaded			Style 47-TT Threaded x Threaded		
Nominal Size Inches mm	Actual Outside Dia. Inches mm	Max. Working Pressure psi kPa	End to End Inches mm	Approx. Wgt. Each Lbs. kg	Max. Working Pressure psi kPa	End to End Inches mm	Approx. Wgt. Each Lbs. kg
½ 15	0.840 21.3	—	—	—	300 2065	3.00 76	0.2 0.1
¾ 20	1.050 26.7	—	—	—	300 2065	3.00 76	0.2 0.1
1 25	1.315 33.7	300 2065	4.00 102	0.3 0.2	300 2065	4.00 102	0.3 0.2
1¼ 32	1.660 42.4	300 2065	4.00 102	0.6 0.3	300 2065	4.00 102	0.6 0.3
1½ 40	1.900 48.3	300 2065	4.00 102	0.8 0.3	300 2065	4.00 102	0.8 0.3
2 50	2.375 60.3	300 2065	4.00 102	1.0 0.5	300 2065	4.00 102	1.0 0.5
2½ 65	2.875 73.0	300 2065	6.00 152	1.6 0.7	300 2065	6.00 152	1.6 0.7
3 80	3.500 88.9	300 2065	6.00 152	2.0 0.9	300 2065	6.00 152	2.0 0.9
3½ 90	4.000 101.6	300 2065	6.00 152	2.3 1.1	300 2065	6.00 152	2.3 1.1
4 100	4.500 114.3	300 2065	6.00 152	4.5 2.0	300 2065	6.00 152	4.5 2.0

Accessories

Dielectric Waterway Fitting

STYLE 47

For Complete Information
Request Publication **09.07**



- Clearflow* dielectric waterway fittings utilize an inert non-corrosive thermoplastic lining that is NSF/FDA listed
 - The thermoplastic lining insulates the inside of the waterway thereby inhibiting formation of local galvanic cell corrosion that occurs between dissimilar metals in the presence of water
 - Designed for continuous use at temperatures up to +230°F/+110°C
 - Style 47-GG (grv. x grv.) is UL-Listed and classified in accordance with ANSI/NSF 61 up to 180°F/82°C for potable water service
 - Pressure rated up to 300psi/2065kPa
 - Sizes from 2–8"/50–200 mm
- * ClearFlow is a registered trademark of Perfection Corp.

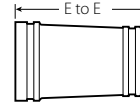

STYLE 47-GG GRV. x GRV.
GROOVED END STEEL TO GROOVED COPPER TRANSITION

Nominal Size Inches mm	Size		Maximum Working Pressure psi kPa	Dimensions End to End Inches mm	Approx. Weight Each Lbs. kg
	Actual Outside Diameter				
	Steel (IPS) Inches mm	Copper (CTS) Inches mm			
2 50	2.375 60.3	2.125 54.0	300 2065	4.19 106	1.3 0.6
2½ 65	2.875 73.0	2.625 66.7	300 2065	6.19 157	3.3 1.5
3 80	3.500 88.9	3.125 79.4	300 2065	6.19 157	4.5 2.0
4 100	4.500 114.3	4.125 104.8	300 2065	6.19 157	5.8 2.6
5 125	5.563 141.3	5.125 130.2	300 2065	6.19 157	7.8 3.5
6 150	6.625 168.3	6.125 155.6	300 2065	6.19 157	10.1 4.6
8 200	8.625 219.1	8.125 206.4	300 2065	6.19 157	15.0 6.8

Advanced Groove System



Victaulic offers Advanced Groove System (AGS) couplings for systems 14-60"/350-1525mm) and a full range of 14-14"/350-600mm AGS fittings, valves and accessories – making AGS a comprehensive solution for large diameter piping. Because the AGS coupling system provides great strength and dependability in addition to speed, it's an excellent choice over welding. Other advantages AGS joints provide over welded joints include no flame, superior seismic-shock resistance and a union at every joint for easy adjustment, system maintenance or system expansion.



Couplings

Rigid Coupling

STYLE W07, PG. 5-3



Flexible Coupling

STYLE W77, PG. 5-3



Rigid Coupling for Stainless Steel Pipe

STYLE W89, PG. 5-4



AGS Vic-Flange® Adapter

STYLE W741, PG. 5-5



ADVANCED GROOVE SYSTEM

Valves

Expansion Joint

STYLE W155, PG. 5-4



Dual Disc Vic Check Valve

SERIES W715, PG. 5-11



Vic-300® MasterSeal™ AGS Butterfly Valve

PG. 5-11, 12



Triple Service Valve Assembly

PG. 5-14



Accessories

Suction Diffuser

SERIES W731-I, PG. 5-15



Vic-Strainer – Tee Type

SERIES W730, PG. 5-16



Wye Type Vic-Strainer®

STYLE W732, PG. 5-17



A complete piping system, for sizes 14–24"/350–600 mm

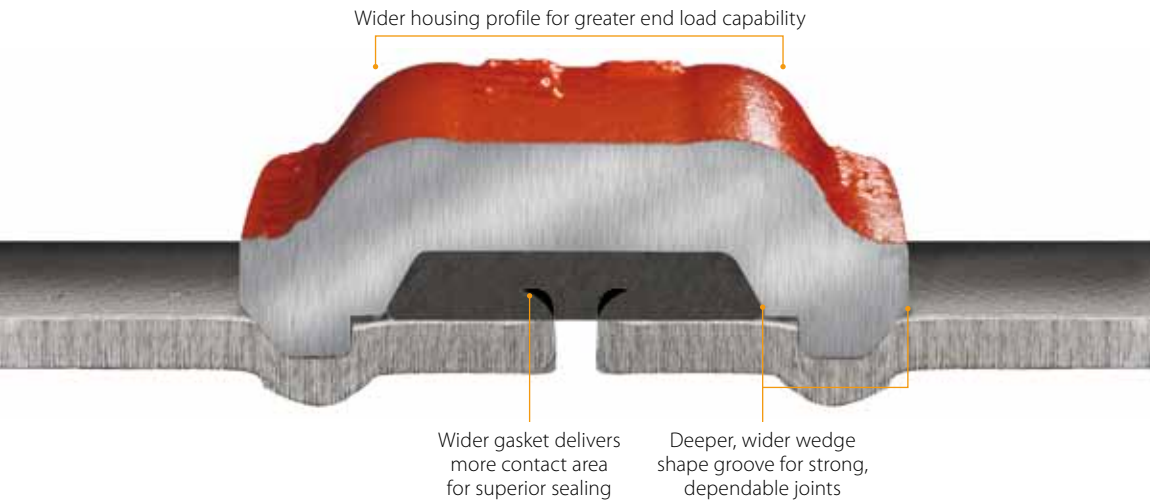

PRODUCTS

- 1-1 Couplings
- 2-1 Fittings
- 3-1 Valves
- 4-1 Accessories
- 5-1 Advanced Groove System**
- 6-1 Hole Cut Piping System
- 7-1 Plain End Piping System
- 8-1 Grooved System for Stainless Steel Pipe
- 9-1 Pressfit System for Stainless Steel Pipe
- 10-1 Plain End Piping System for HDPE Pipe
- 11-1 Grooved Copper
- 12-1 PermaLynx System for Copper Tube
- 13-1 Grooved AWWA Ductile Iron Pipe
- 14-1 Victaulic Depend-O-Lok® System
- 15-1 Aquamine Reusable PVC Products
- 16-1 Gaskets
- 17-1 Pipe Preparation Tools
- 18-1 Product Index
- 19-1 Piping Software

Fittings

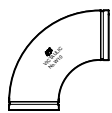

90° Elbow
NO. W10, PG. 5-6

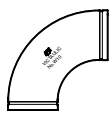

90° 1/2 D Long Radius Elbow
NO. W100, PG. 5-6



True Wye
NO. W33, PG. 5-6



Adapter Nipple
AGS Grv. x Bev.
NO. W42, PG. 5-9



45° Elbow
NO. W11, PG. 5-6



45° 1/2 D Long Radius Elbow
NO. W110, PG. 5-6

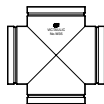

Cross
NO. W35, PG. 5-6



Adapter Nipple
AGS Grv. x AGS Grv.
NO. W43, PG. 5-9



22 1/2° Elbow
NO. W12, PG. 5-6



Tee
NO. W20, PG. 5-6

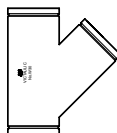

45° Lateral
NO. W30, PG. 5-8



Adapter Nipple*
AGS Grv. x
Non-AGS Grv.
NO. W49, PG. 5-9



Concentric Reducer
NO. W50, PG. 5-10



Cap
NO. W60, PG. 5-9



11 1/4° Elbow
NO. W13, PG. 5-6



Reducing Tee
NO. W25, PG. 5-7

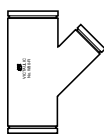

45° Reducing Lateral
NO. W30-R, PG. 5-8



Flanged Adapter Nipple
NO. W45R, PG. 5-9



Eccentric Reducer
NO. W51, PG. 5-10

* ANSI/AWWA C606 Grooved and Shouldered Joints

Rigid Coupling

STYLE W07

For Complete Information
Request Publication 20.02



- Style W07 is the first two-piece, flat pad, metal-to-metal rigid coupling in this size range
- Support and hanging requirements correspond to ASME B31.1 Power Piping code and ASME B31.9 Building Services code
- Pressure rated up to 350 psi/2400 kPa

Size		Max. Work Pressure* psi/kPa		Max. End Load* Lbs./N		Allow. Pipe End Sep.†	Bolt/Nut No - Size	Dimensions - Inches/mm			Approx. Wgt. Each
Nominal Size Inches mm	Actual Outside Dia. Inches mm	Std. Wall	Light Wall ‡	Std. Wall	Light Wall	Inches mm	Inches	X	Y	Z	Lbs. kg
14 350	14.000 355.6	350 § 2500	350 § 2500	55800 248310	55800 248310	0.25 6.4	2 - 1 x 5 1/2	15.87 403	20.59 523	4.75 121	48.9 22.2
16 400	16.000 406.4	350 § 2500	350 § 2500	72885 324338	72885 324338	0.25 6.4	2 - 1 x 5 1/2	18.12 460	23.51 597	4.75 121	60.8 27.6
18 450	18.000 457.0	350 § 2500	350 § 2500	92245 410490	92245 410490	0.25 6.4	2 - 1 x 5 1/2	20.22 514	25.53 648	4.75 121	71.2 32.3
20 500	20.000 508.0	350 § 2500	350 § 2500	113880 506766	113880 506766	0.25 6.4	2 - 1 1/8 x 5 1/2	22.44 570	27.13 389	4.75 121	81.7 37.1
24 600	24.000 610.0	350 § 2500	225 § 1600	163990 729756	104955 467050	0.25 6.4	2 - 1 1/8 x 5 1/2	26.64 677	32.31 821	4.75 121	116.2 52.7

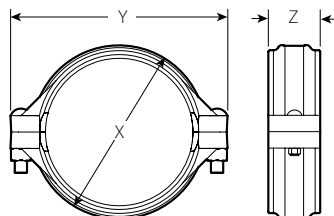

TYPICAL FOR ALL SIZES

- * Working Pressure and End Load are total, from all internal and external loads, based on standard weight (ANSI) steel pipe, AGS **roll** grooved in accordance with Victaulic specifications. Contact Victaulic for performance on other pipe.
- § Pressure ratings have been rounded for global use. Actual maximum working pressure for lightwall in 14-20"/350-500mm sizes is 363 psi/2500kPa; 24"/600mm is 232 psi/1600kPa and standard wall 14-24"/350-500mm sizes is 363 psi/2500kPa.
- WARNING: FOR ONE TIME FIELD TEST ONLY, the Maximum Joint Working Pressure may be increased to 1 1/2 times the figures shown.
- ‡ Lightwall 14"/350mm=0.22"/5.6mm; 16-24"/400-600mm=0.25"/6.35 mm
- # For field installation only on roll grooved pipe. Style W07 AGS couplings are essentially rigid and do not permit expansion/contraction.

IMPORTANT NOTES:

Metric thread size bolts are available (color coded gold) for all coupling sizes upon request. Contact Victaulic for details.

Style W07 AGS couplings must **not** be used to join PVC pipe.

Flexible Coupling

STYLE W77

For Complete Information
Request Publication 20.03



- Style W77 is the only flexible two-piece housing for this size range on the market today
- Style W77 provides limited linear angular movement to accommodate thermal pipe growth, vibration attenuation, seismic and other design considerations that require flexibility
- Pressure rated up to 350 psi/2400 kPa

Size		Max. Work Pressure* psi/kPa		Max. End Load* Lbs./N		Allow. Pipe End Sep.†	Bolt/Nut No - Size	Dimensions - Inches/mm			Approx. Wgt. Each
Nominal Size Inches mm	Actual Outside Dia. Inches mm	Std. Wall	Light Wall ‡	Std. Wall	Light Wall	Inches mm	Inches	X	Y	Z	Lbs. kg
14 350	14.000 355.6	350 § 2500	350 § 2500	55800 248310	55800 248310	0.13 - 0.31 3.3 - 7.9	2 - 1 x 5 1/2	16.00 406	20.59 523	4.50 114	47.5 21.5
16 400	16.000 406.4	350 § 2500	350 § 2500	72885 324338	72885 324338	0.13 - 0.31 3.3 - 7.9	2 - 1 x 5 1/2	18.18 462	23.51 597	4.50 114	57.8 26.2
18 450	18.000 457.2	350 § 2500	350 § 2500	92245 410490	92245 410490	0.13 - 0.31 3.3 - 7.9	2 - 1 x 5 1/2	20.36 517	25.46 647	4.50 114	65.0 29.5
20 500	20.000 508.0	350 § 2500	350 § 2500	113880 506766	113880 506766	0.13 - 0.31 3.3 - 7.9	2 - 1 1/8 x 5 1/2	22.56 573	27.13 389	4.50 114	82.3 37.3
24 600	24.000 609.6	350 § 2500	225 § 1600	163990 729756	104955 467050	0.13 - 0.31 3.3 - 7.9	2 - 1 1/8 x 5 1/2	26.88 683	32.31 821	4.50 114	106.8 48.4

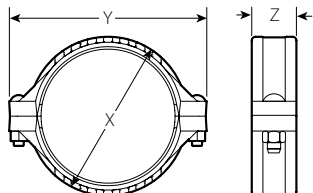

TYPICAL FOR ALL SIZES

- * Working Pressure and End Load are total, from all internal and external loads, based on standard weight (ANSI) steel pipe, AGS **roll** grooved in accordance with Victaulic specifications. Contact Victaulic for performance on other pipe.
- § Pressure ratings have been rounded for global use. Actual maximum working pressure for lightwall in 14-20"/350-500mm sizes is 363 psi/2500 kPa; 24"/600mm is 232 psi/1600 kPa and standard all 14-24"/350-500mm sizes is 363psi/2500kPa.
- WARNING: FOR ONE TIME FIELD TEST ONLY, the Maximum Joint Working Pressure may be increased to 1 1/2 times the figures shown.
- † Allowable Pipe End Separation figures show the maximum nominal range of movement available at each joint for AGS roll grooved pipe. These figures are maximums; for design and installation purposes these figures should be reduced by 25%. Refer to General Notes on pg. 15.

IMPORTANT NOTES:

Metric thread size bolts are available (color coded gold) for all coupling sizes upon request. Contact Victaulic for details.

Style W77 AGS couplings must **not** be used to join PVC pipe.

Rigid Coupling for Stainless Steel Pipe

STYLE W89

For Complete Information
Request Publication 20.15



- Pressure rated up to 300psi/2065kPa
- Style W89 Rigid Coupling greatly reduces linear or angular movement where rigid joint is required

Size		Schedule 10S		Allow. Pipe End Sep.†	Bolt/Nut No - Size	Dimensions			Approx. Wgt. Each
Nominal Size Inches mm	Actual Outside Dia. Inches mm	Max. Work. Pressure* psi kPa	Max. End Load* Lbs. N			X Inches mm	Y Inches mm	Z Inches mm	
14 350	14.000 355.6	300 2065	46200 205590	0.25 6.4	2 - 1 1/8 x 5 1/2	16.50 419	21.38 543	4.81 122	65.0 29.5
16 400	16.000 406.4	300 2065	60320 268424	0.25 6.4		2 - 1 1/8 x 5 1/2	18.88 480	23.50 597	4.81 122
18 450	18.000 457.0	300 2065	76350 339758	0.25 6.4	2 - 1 1/8 x 5 1/2	21.00 533	25.63 651	4.81 122	93.0 42.3
20 500	20.000 508.0	300 2065	94250 419413	0.25 6.4		2 - 1 1/8 x 5 1/2	23.75 603	27.63 702	4.81 122
24 600	24.000 610.0	300 2065	135700 603865	0.25 6.4	2 - 1 1/8 x 5 1/2	30.00 762	32.00 813	4.81 122	182.0 82.6

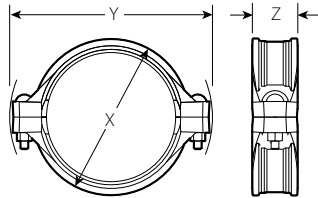

TYPICAL FOR ALL SIZES

* Working Pressure and End Load are total, from all internal and external loads, based on stainless steel pipe, AGS roll grooved in accordance with Victaulic specifications. "RWX" rolls must be used for Schedule 10S. Contact Victaulic for performance on other pipe.

WARNING: FOR ONE TIME FIELD TEST ONLY, the Maximum Joint Working Pressure may be increased to 1 1/2 times the figures shown.

† For field installation only on roll grooved pipe. Style W89 AGS couplings are essentially rigid and do not permit expansion/contraction.

IMPORTANT NOTES:

Metric thread size bolts are available (color coded gold) for all coupling sizes upon request. Contact Victaulic for details.

Expansion Joint

STYLE W155

For Complete Information
Request Publication 20.12



- Combination of couplings and short nipples joined in tandem
- Nipples are precisely grooved to provide full linear allowance at each joint
- May be used as flexible connectors, but will not simultaneously provide full expansion and full deflection
- Expansion joints installed horizontally require independent support to prevent deflection that will reduce the available expansion
- Sizes from 14-24"/350-600mm

Size		Style	Dimensions – Inches/mm					Approx. Wgt. Each	
Nominal Size Inches mm	Actual Outside Dia. Inches mm		Coupling Style	L – Length (ref.) §		X Height	Y Width		Total Minimum Movement Capability
				Compressed	Expanded				
14 350	14.000 355.6	W77	30.00 762	31.75 807	16.63 422	20.00 508	1.75 45	423.0 191.9	
16 400	16.000 406.4		30.00 762	31.75 807	19.00 483	22.38 569	1.75 45	500.0 226.8	
18 450	18.000 457.0	W77	30.00 762	28.00 31.75	21.25 540	24.38 619	1.75 45	632.0 286.7	
20 500	20.000 508.0		30.00 762	31.75 807	23.63 600	27.50 699	1.75 45	800.0 362.9	
24 600	24.000 610.0	W77	30.00 762	31.75 807	27.63 702	31.38 797	1.75 45	840.0 381.0	

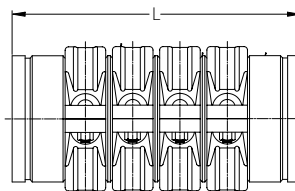
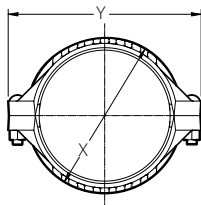

TYPICAL FOR SIZES 14-16"/350-600MM

Vic-Flange® Adaptor

STYLE W741

For Complete Information
Request Publication 20.04.



- Pressure rated up to 300 psi/2065 kPa
- Directly incorporates flanged components to AGS grooved piping systems
- Available in sizes 14-24"/350-600mm

Size		Max. Working Pressure* psi/kPa		Max. End Load* Lbs./N		Assembly Bolts †		Draw Bolts §		Sealing Surface Inches/mm		Dimensions Inches/millimeters								Aprx. Wgt Each
Nml Size Inches	Actual Outside Diameter Inches	Std. Wall	Light Wall ‡	Std. Wall	Light Wall	† No. Bolts Req'd.	Size Inches	No. Bolts	Size Inches	"A" Max.	"B" Min.	T	U	V	W	X	Y	Z	Lbs. kg	
14 350	14.000 355.6	300 2065	300 2065	46180 205501	46180 205501	12	1 x 4½	2	¾ x 3½	14.00 356	16.00 406	19.4 493	1.44 37	0.94 24	24.5 622	21.0 533	18.75 476	2.38 60	66 30	
16 400	16.000 406.4	300 2065	300 2065	60315 268402	60315 268402	16	1 x 4½	2	¾ x 3½	16.00 406	18.00 457	21.5 546	1.44 37	0.94 24	27.1 688	23.5 597	21.25 540	2.38 60	81 37	
18 450	18.000 457.0	300 2065	300 2065	76340 339713	76340 339713	16	1½ x 4¾	2	¾ x 4¼	18.00 457	20.00 508	22.3 566	1.56 40	1.00 25	29.0 737	25.0 635	22.75 578	2.56 65	84 38	
20 500	20.000 508.0	300 2065	300 2065	94250 419413	94250 419413	20	1½ x 5¼	2	¾ x 4¼	20.00 508	22.00 559	24.0 610	1.69 43	1.00 25	31.5 800	27.5 698	25.00 635	2.69 68	110 50	
24 600	24.000 610.0	300 2065	225# 1600	135715 603932	101785 452943	20	1½ x 5¾	2	¾ x 4¼	24.00 610	26.00 660	29.0 737	1.94 49	0.80 20	36.0 914	32.0 813	29.50 749	2.74 70	155 70	

* Working Pressure and End Load are total, from all internal and external loads, based on carbon steel pipe AGS roll grooved in accordance with Victaulic specifications. Contact Victaulic for performance on other pipe.

WARNING: FOR ONE TIME FIELD TEST ONLY, the Maximum Joint Working Pressure may be increased to 1½ times the figures shown.

† Total bolts required to be supplied by installer, may be ordered from Victaulic. Bolt sizes for conventional flange-to-flange connection. Longer bolts required when Vic-Flange utilized with wafer-type valves.

§ Draw bolts supplied with 14 – 24"/350 – 600mm Vic-Flange adapters.

‡ Lightwall 14"/350mm = 0.22"/5.6mm; 16 – 24"/400 – 600mm = 0.25"/6.35mm

Rounded for global use. Actual maximum working pressure is 232psi/1600kPa.

IMPORTANT NOTE:

Style W741 AGS Vic-Flange adaptor provides rigid joints when used on pipe with AGS groove dimensions and consequently allows no linear or angular movement at the joint.

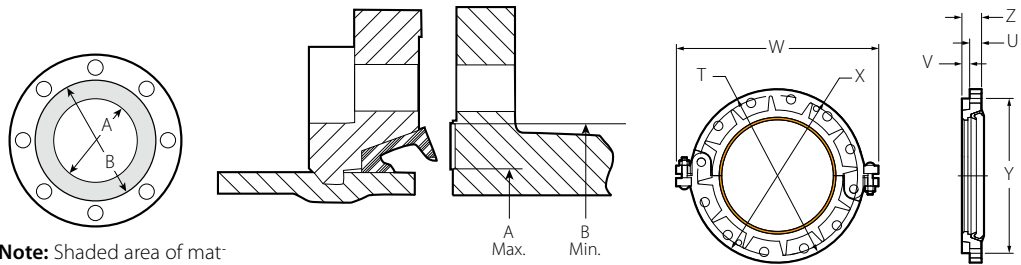

Note: Shaded area of mating face must be free from gouges, undulations or deformities of any type for effective sealing

Exaggerated for clarity

Elbows

- NO. W10** 90° Elbow
- NO. W11** 45° Elbow
- NO. W12** 22½° Elbow
- NO. W13** 11¼° Elbow
- NO. W100** 90° Long Radius
- NO. W110** 45° Long Radius
(Ductile Iron#)

Request Publication
20.05

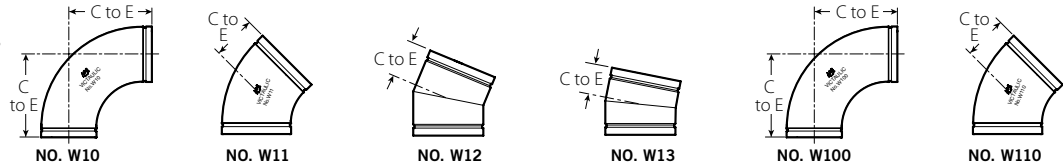

Size		No. W10 90° Elbow		No. W11 45° Elbow		No. W12 22½° Elbow (sw)		No. W13 11¼° Elbow (sw)		No. W100† 90° Long Radius Elbow (S)		No. W110† 45° Long Radius Elbow (S)	
Nominal Size Inches mm	Actual Outside Dia. Inches mm	C to E Inches mm	Approx. Wgt. Each Lbs. kg	C to E Inches mm	Approx. Wgt. Each Lbs. kg	C to E Inches mm	Approx. Wgt. Each Lbs. kg	C to E Inches mm	Approx. Wgt. Each Lbs. kg	C to E Inches mm	Approx. Wgt. Each Lbs. kg	C to E Inches mm	Approx. Wgt. Each Lbs. kg
14	14.000	14.00	150.8	5.80	63.0	5.00	46.0	3.50	32.0	21.00	158.0	8.75	83.0
350	355.6	355.6	68.4	147	28.7	127	20.9	89	14.5	533	71.7	222	37.6
16	16.000	16.00	184.3	6.63	93.8	5.00	52.1	4.00	42.0	24.00	204.3	10.00	101.0
400	406.4	406.4	83.6	168	42.5	127	23.6	102	19.1	610	92.7	254	45.8
18	18.000	18.00	272.3	7.46	129.0	5.50	65.0	4.50	53.2	27.00	260.0	11.25	127.0
450	457.0	457.0	123.5	189	58.5	140	29.5	114	24.1	686	118.0	286	57.6
20	20.000	20.00	312.0	8.28	165.3	6.00	78.6	5.00	65.0	30.00	328.5	12.50	167.0
500	508.0	508.0	141.5	210	75.0	152	36.0	127	29.5	762	149.0	318	75.7
24	24.000	24.00	559.8	9.94	264.5	7.00	110.3	6.00	94.5	36.00	490.0	15.00	244.8
600	610.0	610.0	253.9	252	120.0	178	50.0	152	42.9	914	222.3	381	110.1

Ductile iron except those marked (sw) which are segmentally welded steel or (S) which are steel.

† For the U.S. 14"/350 mm, 16"/400 mm, 18"/450 mm, 20"/500 mm, 24"/600 mm elbows (90°, 45°) are 1½ D long radius forged steel elbows No. W100 and No. W110.

* Available for special order.

Tees, Crosses and Wyes

- NO. W20** Tee
- NO. W35** Cross
- NO. W33** True Wye
- (Ductile Iron#)

For Complete Information
Request Publication **20.05**

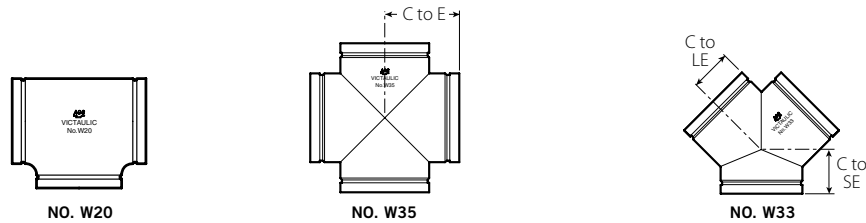

Size		No. W20 Tee		No. W35 Cross (sw)		No. W33 True Wye (sw)		
Nominal Size Inches mm	Actual Outside Diameter Inches mm	C to E Inches mm	Approx. Weight Each Lbs. kg	C to E Inches mm	Approx. Weight Each Lbs. kg	C to LE Inches mm	C to SE Inches mm	Approx. Weight Each Lbs. kg
14	14.000	11.00	102.0	11.00	121.0	11.00	7.50	98.0
350	355.6	279	46.3	279	54.9	279	191	44.4
16	16.000	12.00	123.5	12.00	146.4	12.00	8.00	119.3
400	406.4	305	56.0	305	66.4	305	203	54.1
18	18.000	13.50	281.0	13.50	185.4	13.50	8.50	148.3
450	457.0	343	127.5	343	84.1	343	216	67.3
20	20.000	15.00	350.0	15.00	229.1	15.00	9.00	180.4
500	508.0	381	158.7	381	103.9	381	229	81.8
24	24.000	17.00	503.7	17.00	298.7	17.00	10.00	238.3
600	610.0	432	228.5	432	135.5	432	254	108.1

Ductile iron except those marked with (sw) which are segmentally welded.

Reducing Tee

NO. W25

(Segmentally Welded Steel)

For Complete Information
Request Publication 20.05

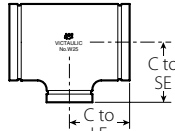

NO. W25

ADVANCED GROOVE SYSTEM

Size			No. W25 Reducing Tee		Approx. Weight Each
Nominal Size Inches	Inches	mm	C to LE Inches	C to SE Inches	Lbs. kg
14 350	14 350	6 150	11.00 279	9.38 238	101.4 46.0
		8 200	11.00 279	9.75 248	102.5 46.5
		10 250	11.00 279	10.12 257	105.1 47.7
		12 300	11.00 279	10.62 270	108.1 49.0
16 400	16 400	6 150	12.00 305	10.38 264	126.2 57.2
		8 200	12.00 305	10.75 273	127.4 57.8
		10 250	12.00 305	11.12 282	129.8 58.9
		12 300	12.00 305	11.62 295	132.5 60.1
		14 350	12.00 305	12.00 305	134.6 61.1
18 450	18 450	6 150	13.50 343	11.38 289	160.0 72.6
		8 200	13.50 343	11.75 298	161.0 73.0
		10 250	13.50 343	12.12 308	163.1 74.0
		12 300	13.50 343	12.62 321	165.6 75.1
		14 350	13.50 343	13.00 330	167.6 76.0
		16 400	13.50 343	13.00 330	168.2 76.3

Size			No. W25 Reducing Tee		Approx. Weight Each
Nominal Size Inches	Inches	mm	C to LE Inches	C to SE Inches	Lbs. kg
20 500	20 500	6 150	15.00 381	12.38 314	197.0 89.5
		8 200	15.00 381	12.75 324	198.5 90.0
		10 250	15.00 381	13.12 333	200.5 90.9
		12 300	15.00 381	13.62 346	202.9 92.0
		14* 350	15.00 381	14.00 356	204.7 92.9
		16* 400	15.00 381	14.00 356	205.0 93.0
		18 450	15.00 381	14.50 368	208.4 94.5
24 600	24 600	6 150	17.00 432	14.38 365	260.9 122.0
		8 200	17.00 432	14.75 375	270.0 123.0
		10 250	17.00 432	15.12 384	271.7 123.2
		12 300	17.00 432	15.62 397	273.8 124.2
		14 350	17.00 432	16.00 406	275.4 125.0
		16 400	17.00 432	16.00 406	275.4 125.0
		18 450	17.00 432	16.50 419	278.1 127.1
		20 500	17.00 432	17.00 432	282.1 128.0

* Cast fitting available. Contact Victaulic for details.

IMPORTANT NOTE:

Outlets 12"/300 mm and smaller will be provided with standard Victaulic roll or cut grooves, suitable for use with standard Victaulic grooved couplings in that size range.

45° Lateral

NO. W30

(Segmentally Welded Steel)

For Complete Information
Request Publication **20.05**

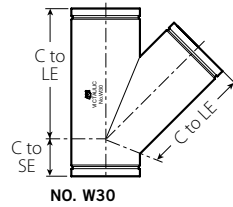

45° Reducing Lateral

NO. W30-R

(Segmentally Welded Steel)

For Complete Information
Request Publication **20.05**

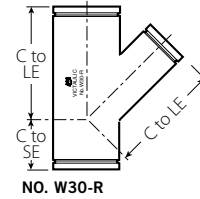

Size		No. W30 45° Lateral		
Nominal Size Inches mm	Actual Outside Diameter Inches mm	C to LE Inches mm	C to SE Inches mm	Approx. Weight Each Lbs. kg
14 350	14.000 355.6	26.50 673	7.50 191	219.1 99.4
16 400	16.000 406.4	29.00 737	8.00 203	270.5 122.7
18 450	18.000 457.0	32.00 813	8.50 216	332.7 150.9
20 500	20.000 508.0	35.00 889	9.00 229	401.3 182.0
24 600	24.000 610.0	40.00 1016	10.00 254	541.3 245.5

Size			No. W30-R Reducing Lateral		
Nominal Size Inches mm	C to LE Inches mm	C to SE Inches mm	Approx. Weight Each Lbs. kg		
14 350	14 350	4 100	26.50 673	7.50 191	175.9 79.8
		6 150	26.50 673	7.50 191	185.9 84.3
		8 200	26.50 673	7.50 191	195.0 88.4
		10 250	26.50 673	7.50 191	204.4 92.7
		12 300	26.50 673	7.50 191	213.3 96.8
16 400	16 400	6 150	29.00 737	8.00 203	226.4 102.7
		8 200	29.00 737	8.00 203	236.0 107.1
		10 250	29.00 737	8.00 203	246.0 111.6
		12 300	29.00 737	8.00 203	255.1 115.7
		14 350	29.00 737	8.00 203	260.9 118.4
18 450	18 450	6 150	32.00 813	8.50 216	274.8 124.6
		8 200	32.00 813	8.50 216	285.3 129.4
		12 300	32.00 813	8.50 216	306.2 138.9
		14 350	32.00 813	8.50 216	312.4 141.7
		16 400	32.00 813	8.50 216	322.4 146.2
20 500	20 500	12 300	35.00 889	9.00 229	362.1 164.3
		14 350	35.00 889	9.00 229	368.7 167.2
		16 400	35.00 889	9.00 229	379.4 172.1
24 600	24 600	16 400	40.00 1016	10.00 254	494.9 224.5
		20 600	40.00 1016	10.00 254	517.7 254.8

IMPORTANT NOTE:

Outlets 12"/300 mm and smaller will be provided with standard Victaulic roll or cut groove, suitable for use with standard Victaulic grooved couplings in that size range.

Adapter Nipple

- NO. W42** AGS Grv. × Bev.
- NO. W43** AGS Grv. × AGS Grv.
- NO. W49** AGS Grv. × Non-AGS Grv. (Steel)

Request Publication **20.05**

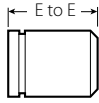

NO. W42

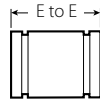

NO. W43

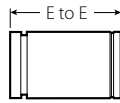

NO. W49

Size		No. W42, W43, W49 Adapter Nipple (sw)	
Nominal Size Inches mm	Actual Outside Diameter Inches mm	E to E Inches mm	Approx. Weight Each Lbs. kg
14 350	14.000 355.6	8.00 203	36.0 16.3
16 400	16.000 406.4	8.00 203	42.0 19.1
18 450	18.000 457.0	8.00 203	47.0 21.3
20 500	20.000 508.0	8.00 203	52.0 23.6
24 600	24.000 610.0	8.00 203	63.0 28.6

Flanged Adapter Nipple

- NO. W45R** ANSI Class 150 Raised Face (Steel)

For Complete Information Request Publication **20.05**

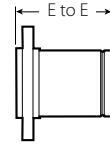

NO. W45R

Size		No. W45R Flanged Adapter Nipple	
Nominal Size Inches mm	Actual Outside Diameter Inches mm	E to E Inches mm	Approx. Weight Each Lbs. kg
14 350	14.000 355.6	8.00 203	122.0 55.3
16 400	16.000 406.4	8.00 203	136.0 61.7
18 450	18.000 457.0	8.00 203	168.0 76.2
20 500	20.000 508.0	8.00 203	208.0 94.3
24 600	24.000 610.0	8.00 203	274.0 124.3

Cap

- NO. W60** (Steel)

For Complete Information Request Publication **20.05**

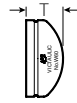

NO. W60

Size		No. W60 Cap	
Nominal Size Inches mm	Actual Outside Diameter Inches mm	T Thickness Inches mm	Approx. Weight Each Lbs. kg
14 350	14.000 355.6	6.50 165	33.2 15.1
16 400	16.000 406.4	7.00 178	41.2 18.7
18 450	18.000 457.0	8.00 203	54.6 24.8
20 500	20.000 508.0	9.00 229	67.5 30.6
24 600	24.000 610.0	10.50 267	96.0 43.5

Concentric/Eccentric Reducer

NO. W50 Concentric

NO. W51 Eccentric
(Steel†)

For Complete Information
Request Publication **20.05**

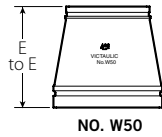

NO. W50

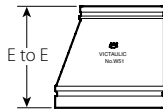

NO. W51

Size	No. W50 Concentric Reducer		No. W51 Eccentric Reducer		
	Nominal Size Inches mm	E to E Inches mm	Approx. Weight Each Lbs. kg	E to E Inches mm	Approx. Weight Each Lbs. kg
14 350 ×	6 150	13.00 330	68.0 30.8	13.00 330	68.0 30.8
	8 200	13.00 330	70.0 31.8	13.00 330	70.0 31.8
	10 250	13.00 330	72.0 32.7	13.00 330	72.0 32.7
	12 300	13.00 330	74.0 33.6	13.00 330	74.0 33.6
16 400 ×	8 200	14.00 356	88.0 39.9	14.00 356	88.0 39.9
	10 250	13.00 330	91.0 41.3	13.00 330	91.0 41.3
	12 300	14.00 356	93.0 42.2	14.00 356	93.0 42.2
	14 350	14.00 356	95.0 43.1	14.00 356	95.0 43.1
18 450 ×	14 350	15.00 381	112.0 50.8	15.00 381	112.0 50.8
	16 400	15.00 381	115.0 52.2	15.00 381	115.0 52.2
	18 450	15.00 381	118.0 53.5	15.00 381	118.0 53.5
	20 500	15.00 381	121.1 54.9	15.00 381	121.1 54.9

Size	No. W50 Concentric Reducer		No. W51 Eccentric Reducer		
	Nominal Size Inches mm	E to E Inches mm	Approx. Weight Each Lbs. kg	E to E Inches mm	Approx. Weight Each Lbs. kg
20 500 ×	12 300	20.00 508	160.0 72.6	20.00 508	160.0 72.6
	14 350	20.00 508	164.0 74.4	20.00 508	164.0 74.4
	16 400	20.00 508	168.0 76.2	20.00 508	168.0 76.2
	18 450	20.00 508	172.0 78.0	20.00 508	172.0 78.0
24 600 ×	16 400	20.00 508	198.0 89.9	20.00 508	198.0 89.9
	18 450	20.00 508	200.0 90.7	20.00 508	200.0 90.7
	20 500	20.00 508	204.0 92.5	20.00 508	204.0 92.5

† Some fitting sizes are available in cast ductile iron.
Contact Victaulic for details.

IMPORTANT NOTE:

Outlets 12"/300mm and smaller will be provided with standard Victaulic roll or cut grooves, suitable for use with standard Victaulic grooved couplings in that size range.

Dual Disc Vic Check Valve

SERIES W715

For Complete Information
Request Publication 20.08



Size		Dimensions			Approx. Weight Each	Flow Coefficient@ (Fully Open)
Nominal Size Inches mm	Actual Outside Diameter Inches mm	A End to End Inches mm	B Inches mm	C Inches mm	Lbs. kg	C _v Values K _v Values
14 350	14.000 355.6	10.75 273	16.93 430	14.38 366	140.0 64.0	6000 5190.0
16 400	16.000 406.4	12.00 305	19.88 505	16.38 416	160.0 73.0	8300 7179.5
18 450	18.000 457.0	14.25 362	21.54 547	18.38 467	180.0 82.0	10500 9082.5
20 500	20.000 508.0	14.50 368	24.75 628	20.38 518	200.0 91.0	13800 11937.0
24 600	24.000 610.0	15.50 394	28.81 732	24.38 620	240.0 109.0	20500 17732.5

@ C_v/K_v values for flow of water at +60°F/+16°C with valve fully open.

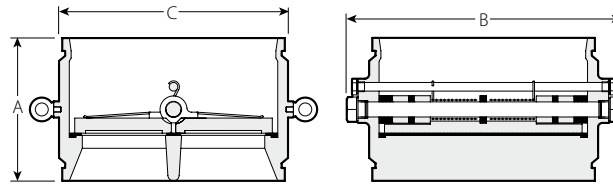

TYPICAL FOR ALL SIZES

- Can be installed in both horizontal or vertical “flow up” positions
- Constructed of rugged ductile iron, the valve features an EPDM seat bonded to the body and a 304 stainless steel disc and shaft
- Utilizes a spring-assisted, dual disc design that achieves drop tight sealing over the full 230 psi/16 Bar pressure rating
- Sizes from 14–24”/350–600mm

AGS Vic-300® MasterSeal™ Butterfly Valve

For Complete Information
Request Publication **20.06**

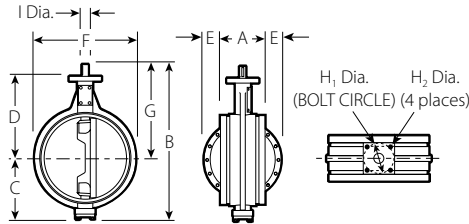

TYPICAL FOR ALL SIZES

- Available with handwheel gear operator, electric, pneumatic or hydraulic actuators and two and three way configurations
- Easier to install than cumbersome multi-bolt wafer, lug type or flanged valves
- Features AGS grooved ends for 14–24"/350–600mm systems for 300 psi/2065 kPa bi-directional services

AGS VIC-300 MASTERSEAL BUTTERFLY VALVE WITHOUT GEAR OPERATOR

Size		Dimensions											Approx. Wgt. Each
Nominal Size Inches mm	Actual Outside Diameter Inches mm	A End to End Inches mm	B Overall Height Inches mm	C Inches mm	D Inches mm	E Inches mm	F Inches mm	G Inches mm	Mounting †			w/o Oper. Lbs. kg	
									H ₁ Dia. Inches mm	H ₂ Dia. Inches mm	I Dia. Inches mm		
14 350	14.000 355.6	10.00 254	24.45 621	9.68 246	12.89 327	1.16 29	16.00 406	14.77 375	4.96 126	0.578 15	1.38 35	125.0 56.7	
16 400	16.000 406.4	10.50 267	27.14 689	10.94 278	14.10 358	1.90 48	18.00 457	16.20 412	4.96 126	0.578 15	1.50 38	153.0 69.4	
18 450	18.000 457.0	11.00 279	29.56 751	12.31 313	15.00 381	2.64 59	20.00 508	17.25 438	4.96 126	0.578 15	1.75 45	199.0 90.3	
20 500	20.000 508.0	11.50 292	32.64 829	14.06 357	16.10 409	3.42 87	23.00 584	18.58 472	5.51 140	0.672 17	2.00 51	285.0 129.3	
24 600	24.000 610.0	12.00 305	38.89 988	16.06 408	20.10 511	5.17 131	26.70 678	22.83 580	6.50 165	0.844 21	2.25 57	451.0 204.6	

† MOUNTING KEY:

- 14"/350 mm – 3/8 Sq. × 1 7/8
- 16"/400 mm – 3/8 Sq. × 2 1/2
- 18"/450 mm – (2) 3/8 Sq. × 2
- 20"/500 mm – (2) 1/2 Sq. × 2 1/4
- 24"/600 mm – (2) 5/8 Sq. × 3

IMPORTANT NOTES:

Dimensions provided without operator are for sizing data only. AGS Vic-300 MasterSeal butterfly valves should never be installed without operators.

AGS Vic-300 MasterSeal butterfly valves have longer end to end dimensions and AGS groove dimensions and cannot be used to replace existing Series 706 butterfly valves.

AGS Vic-300® MasterSeal™ Butterfly Valve

For Complete Information
Request Publication **20.06**

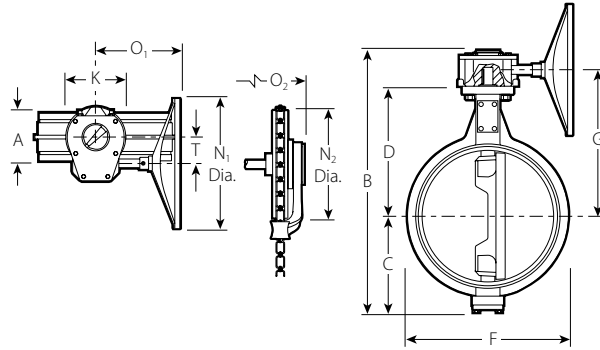

TYPICAL FOR ALL SIZES

AGS VIC-300 MASTERSEAL BUTTERFLY VALVE WITH GEAR OPERATOR

Size		Dimensions													No. Turns to Close	Approx. Wgt. Each	Flow Coefficient@ (Fully Open) C _v Values K _v Values
Nominal Size Inches mm	Actual Outside Diameter Inches mm	A End to End Inches mm	B Overall Height Inches mm	C Inches mm	D Inches mm	F Inches mm	G Inches mm	K Inches mm	Handwheel		Chain Wheel		T Inches mm				
									N ₁ Dia. Inches mm	O ₁ Inches mm	N ₂ Dia. Inches mm	O ₂ Inches mm					
14 350	14.000 355.6	10.00 254	26.17 665	9.68 246	12.89 327	16.00 406	14.54 367	7.87 200	19.70 500	12.86 327	21.50 546	16.00 406	3.02 77	9.5	156.0 70.8	9360 8096.4	
16 400	16.000 406.4	10.50 267	29.00 737	10.94 278	14.10 358	18.00 457	15.99 406	8.66 220	19.70 500	14.34 364	21.50 546	17.47 444	3.38 86	13.75	201.0 91.2	12400 10726.0	
18 450	18.000 457.0	11.00 279	32.17 817	12.31 313	15.00 381	20.00 508	17.17 436	11.22 285	27.60 700	15.55 395	30.00 762	18.68 474	4.38 111	21	269.5 122.2	15900 13753.5	
20 500	20.000 508.0	11.50 292	36.23 920	14.06 357	16.10 409	23.00 584	18.27 464	11.22 285	27.60 700	18.43 468	30.00 762	21.60 549	5.38 137	52	384.2 174.3	19800 17127.0	
24 600	24.000 610.0	12.00 305	42.41 1017	16.06 408	20.10 511	26.70 678	22.42 569	14.57 370	27.60 700	20.51 521	30.00 762	23.60 599	5.38 137	79.25	605.0 274.4	28900 24998.5	

@ C_v/K_v values for flow of water at +60°F/+16°C with valve fully open.

Triple Service Valve Assembly

For Complete Information
Request Publication **20.18**



AGS TRI-SERVICE BUTTERFLY/CHECK VALVE COMBINATION

Valve Size		Dimensions – Inches/millimeters				Approx. Assembly Wgt. Lbs/kg
Nominal Diameter Inches/mm	Actual Outside Diameter Inches/mm	A Inches/mm	B Inches/mm	C Inches/mm	D Inches/mm	
14 350	14 355.6	29.25 743.0	14.50 368.3	19.75 501.7	24.50 622.3	430 195.0
16 400	16 406.4	31.00 787.4	16.00 406.4	19.75 501.7	25.88 657.4	525 238.1
18 450	18 457.2	33.75 857.3	17.13 435.1	27.63 701.8	31.00 787.4	639 289.9
20 500	20 508.0	34.50 876.3	18.25 463.6	27.63 701.8	32.13 816.1	799 362.4
24 600	24 609.6	36.00 914.4	22.50 571.5	27.63 701.8	36.25 920.8	1140 517.1

- Assembly of the Series W761 AGS Vic-300 butterfly valve and Series W715 AGS Vic-Check valve
- Provides shut-off, throttling with positive mechanical memory and non-slam check service in one unit.
- Available in sizes 14-24"/350-600mm
- Pressure rated up to 232psi/1600kPa.

DIMENSIONS

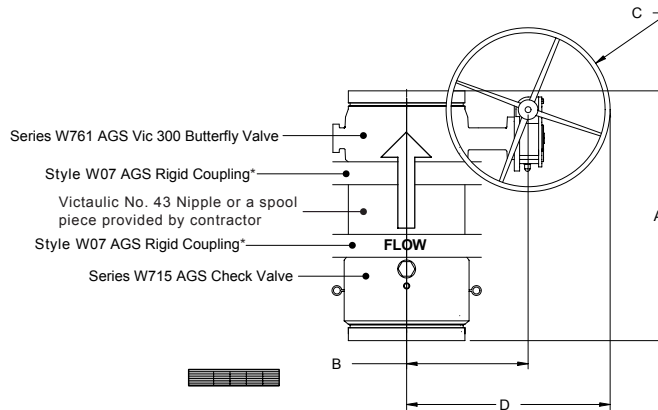

14 – 24"/350 – 600MM TYPICAL WITH SERIES W761 AGS VIC-300 BUTTERFLY VALVES AND SERIES W715 AGS VIC-CHECK VALVES

Suction Diffuser

SERIES W731-I

For Complete Information
Request Publication **20.13**



- Series W731-I provides optimum flow conditions at the inlet side of the pump
- Bosses are provided on either side for pressure measurement
- Coupling secures closure cap greatly reducing down time for maintenance
- Pressure rated up to 300psi/2065kPa

Size		Dimensions Inches/mm								Approx. Wgt. Each	
System Side Inlet	Pump Side Outlet	C-E1	C-E2	CLR	C-O	D	L	OAL	OAW	Lbs. kg	
Nominal Size Inches mm											
14 350	10 250	-	23.13 588	28.00 711	17.13 435	5.32 135	8.93 227	29.00 737	17.25 438	410.0 186.0	
	12 300	11.00 279	-	35.00 889	24.13 613	5.88 149	9.95 253	37.50 953	20.25 514	434.0 196.9	
	14 350	-	26.13 664	39.00 991	26.13 664	6.88 175	11.03 280	40.56 1030	24.50 622	711.0 322.5	
16 400	12 300	-	26.13 664	35.00 889	24.13 613	5.88 149	9.95 253	37.50 953	17.25 438	583.0 264.5	
	14 350	12.00 305	-	39.00 991	26.13 664	6.88 175	11.03 280	40.56 1030	24.50 622	551.0 249.9	
18 450	16 400	13.50 343	-	43.00 1092	28.63 727	7.88 200	12.14 308	44.50 1130	27.13 689	678.0 307.5	
24 600	24 600	17.00 432	-	55.00 1397	37.13 943	10.88 276	15.63 397	54.25 1378	13.50 800	1102.0 499.9	

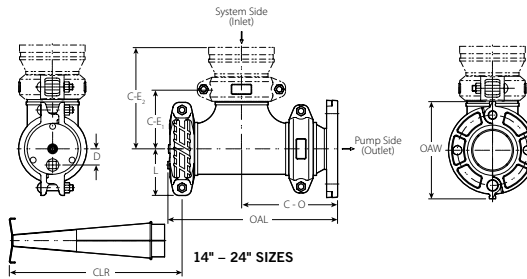

† Pump side flange ANSI Class 150.

IMPORTANT NOTE: Maximum differential pressure from inlet to outlet must not exceed 10 psi/69 kPa.

Vic-Strainer – Tee Type

SERIES W730

For Complete Information Request Publication 20.11



Size		Max. Work Pressure psi kPa	Dimensions					Approx. Wgt. Each Lbs. kg	Flow Coefficient@ (Fully Open) C _v Values K _v Values
Nominal Size Inches mm	Actual Outside Diameter Inches mm		A Inches mm	B Inches mm	X* Inches mm	Y* Inches mm	H N.P.T. Inches mm		
14 350	14.000 355.6	300 2065	22.00 559	17.75 451	12.25 311	17.70 450	2.00 51	300.0 136.1	5050 4368.3
16 400	16.000 406.4	300 2065	24.00 610	18.75 476	13.75 349	20.50 521	2.00 51	350.0 158.8	8000 6920.0
18 450	18.000 457.0	300 2065	31.00 787	23.25 591	15.25 387	23.30 592	2.00 51	400.0 181.4	10540 9117.1
20 500	20.000 508.0	300 2065	34.50 876	25.88 657	16.94 430	25.50 648	2.00 51	565.0 256.3	11960 10345.4
24 600	24.000 610.0	300 2065	40.00 1016	30.13 765	19.94 506	28.30 719	2.00 51	830.0 376.5	17222 14897.0

@ C_v/K_v values for flow of water at +60°F/+16°C.

* See minimum clearance requirement table below.

IMPORTANT NOTE:

Maximum differential pressure from inlet to outlet must not exceed 10 psi/69 kPa.

- Series W730 provides straight-through flow for low pressure drop
- Access cap permits easy cleaning
- Pressure rated up to 300 psi/2065 kPa

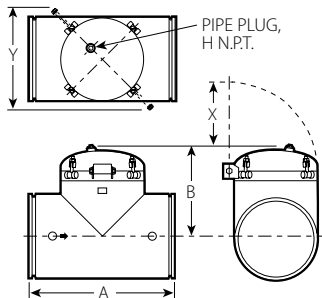

TYPICAL FOR ALL SIZES

Recommended Minimum Clearance Required to Remove Diffuser Basket

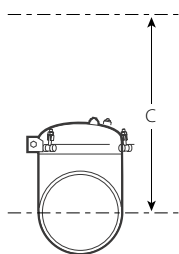

Recommended Minimum Clearance Required to Remove Strainer Basket		
Nominal Size Inches mm	Actual Outside Diameter Inches mm	C Strainer Basket Clearance† Dimensions Inches mm
14 350	14.000 355.6	30.00 762
16 400	16.000 406.4	32.00 813
18 450	18.000 457.0	35.00 889
20 500	20.000 508.0	38.00 965
24 600	24.000 610.0	44.00 1118

† Measurement is from the center line to the top of the basket during removal.

Wye Type Vic-Strainer®

STYLE W732

For Complete Information
Request Publication 20.19.



Size		Max. Work Pressure	Dimensions – Inches/mm													Approx. Wgt. Each
Nominal Size Inches/ mm	Actual Outside Diameter Inches/ mm	psi kPa	End to End		Dimensions – Inches/mm								K "TAP"	L	M	Lbs. kg
			A	B	C	D	E	F	G	H	J					
14	14.00	300	34.00	25.93	8.07	25.27	29.13	18.15	20.59	2 NPT	7.09	¼"	3.35	7.87	425	
350	355.60	2065	863.6	658.6	205	641.8	739.8	461	523.0	2 NPT	180	NPT	85	200.0	192.8	
16	16.00	300	37.00	27.35	9.65	27.15	30.70	20.47	23.51	2 NPT	7.87	¼"	3.74	8.88	600	
400	406.40	2065	939.8	694.8	245	689.5	779.8	520	597.2	2 NPT	200	NPT	95	225.5	272.2	
18	18.00	300	40.51	30.27	10.24	29.94	33.61	23.39	25.53	2 NPT	7.87	¼"	3.74	9.88	800	
450	457.20	2065	1028.9	768.9	260	760.5	853.8	594	648.5	2 NPT	200	NPT	95	251.0	362.9	

#Working pressure is maximum and will be governed by couplings used for installation and related system components. Maximum differential pressure from inlet to outlet must not exceed 10 psi/69 kPa.

*Dimensions will vary depending upon coupling orientation.

- Provides straight through flow for lower pressure drop
- Access cap provides easy cleaning
- Pressure rated up to 300 psi/2065 kPa
- Available in sizes 14-18"/350-450mm

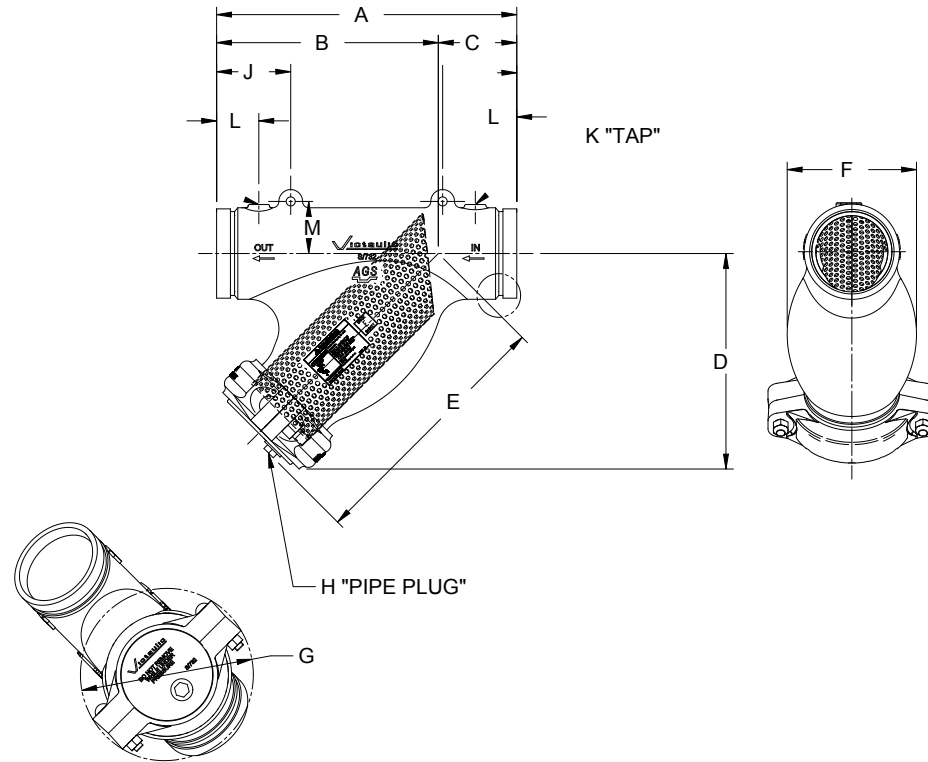

ADVANCED GROOVE SYSTEM

MINIMUM CLEARANCE REQUIREMENTS FOR REMOVAL OF SUCTION DIFFUSER BASKETS

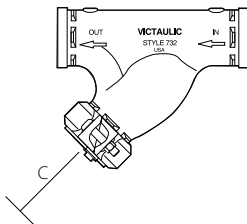

Pipe Size		"C" Strainer Basket Minimum Clearance inches/mm
Nominal Diameter inches/mm	Actual Outside Diameter inches/mm	Series W732
14	14.000	30.00
350	355.6	762
16	16.000	32.00
400	406.4	813
18	18.000	35.00
450	457.0	889

Hole Cut Piping System

- Victaulic developed the concept of a fast, easy mid-pipe outlet that would not require welding
- Gaskets are molded to conform to the O.D. of the pipe and are of a pressure responsive design
- Request publication 11.01
- Victaulic hole cut products are mounted to the pipe using either a locating collar (Style 920 and 920N) or a toe and heel (Style 923/924), and provide a smooth flow area

Hole Cutting Tools



The Vic-Tap is perfect for applications where systems cannot be shut down to add branch connections. Capable of tapping into steel pipe systems under pressures up to 500 psi/3450 kPa Vic-Tap automatically reduces the piping coupon avoiding possible damage to equipment in the pipe line, see pg. 17-11.

Mechanical-T® Bolted Branch Outlet

STYLE 920 AND STYLE 920N GROOVED OUTLET, PG. 6-2



Mechanical-T Bolted Branch Outlet

STYLE 920 AND STYLE 920N FEMALE THREADED OUTLET, PG. 6-2



Mechanical-T Bolted Branch Outlet

STYLE 920 CROSS, PG. 6-4



PRODUCTS

- 1-1 Couplings
- 2-1 Fittings
- 3-1 Valves
- 4-1 Accessories
- 5-1 Advanced Groove System
- 6-1 Hole Cut Piping System**
- 7-1 Plain End Piping System
- 8-1 Grooved System for Stainless Steel Pipe
- 9-1 Pressfit System for Stainless Steel Pipe
- 10-1 Plain End Piping System for HDPE Pipe
- 11-1 Grooved Copper
- 12-1 PermaLynx System for Copper Tube
- 13-1 Grooved AWWA Ductile Iron Pipe
- 14-1 Victaulic Depend-O-Lok® System
- 15-1 Aquamine Reusable PVC Products
- 16-1 Gaskets
- 17-1 Pipe Preparation Tools
- 18-1 Product Index
- 19-1 Piping Software

Vic-Let™ Strapless Outlet

STYLE 923, PG. 6-5



Vic-O-Well™ Strapless Thermometer Outlet

STYLE 924, PG. 6-6



Mechanical-T Bolted Branch Outlet

STYLE 622, PG. 11-5



Mechanical-T Bolted Branch Crosses

STYLE 622, PG. 11-5



Hole Cut Piping System

Mechanical-T Bolted Branch Outlet

STYLE 920/920N

Grooved/Female Threaded Outlet

For Complete Information
Request Publication **11.02**

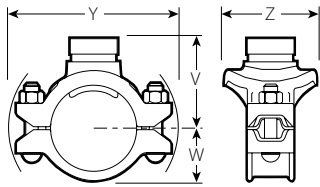
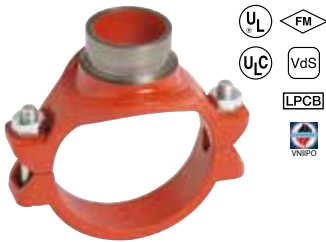

GROOVED OUTLET

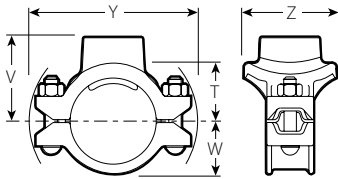
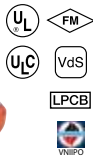
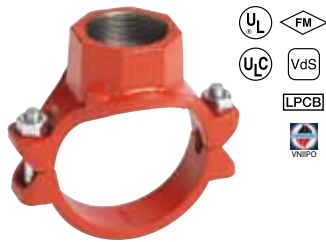

FEMALE THREADED OUTLET

- Provide a direct branch connection at any location where a hole can be cut in the pipe
- A pressure responsive gasket provides the seal
- Pressure rated up to 400 psi/2750 kPa
- Sizes from 2 x 1/2"/50 x 15 mm through 8 x 4"/200 x 100 mm

Size	Style No.	Max. Work Pressure@	Dimensions							Approx. Weight Each			
			Run x Branch Nominal Size Inches mm	920 or 920N	psi kPa	Hole Diameter +0.13 -0.00	T ** Inches mm	V †# Threaded Inches mm	V † Grooved Inches mm	W Inches mm	Y Inches mm	Z Inches mm	Female Threaded Lbs. kg
2 50	x	1/2 (a) □ 15	920N	400 2750	1.50 38.1	2.00 51	2.53 64	—	1.61 41	5.35 136	2.75 70	3.1 1.5	—
			920N	400 2750	1.50 38.1	1.97 50	2.53 64	—	1.61 41	5.35 136	2.75 70	3.1 1.5	—
	x	1 (a) □ 25	920N	400 2750	1.50 38.1	1.85 47	2.53 64	—	1.61 41	5.35 136	2.75 70	3.0 1.4	—
		1 1/4 (a) † □ 32	920N	400 2750	1.75 44.5	2.05 52	2.75 70	3.00 76	1.61 41	5.35 136	3.00 76	3.5 1.7	3.2 1.5
		1 1/2 (a) † □ 40	920N	400 2750	1.75 44.5	2.03 52	2.75 70	3.12 79	1.61 41	5.35 136	3.25 83	3.6 1.7	3.2 1.5
2 1/2 65	x	1/2 (a) § □ 15	920N	400 2750	1.50 38.1	2.21 56	2.74 70	—	91.82 46	5.64 143	2.75 70	3.0 1.4	—
			920N	400 2750	1.50 38.1	2.18 55	2.74 70	—	1.82 46	5.64 143	2.75 70	3.0 1.4	—
	x	1 (a) § □ 25	920N	400 2750	1.50 38.1	2.06 52	2.74 70	—	1.82 46	5.64 143	2.75 70	2.9 1.4	—
		1 1/4 † (a) □ 32	920N	400 2750	1.75 44.5	2.30 58	3.00 76	3.25 83	1.82 46	6.29 160	3.00 76	3.5 1.7	3.2 1.5
		1 1/2 † (a) □ 40	920N	400 2750	2.00 50.8	2.28 58	3.00 76	3.25 83	1.82 46	6.26 159	3.25 83	3.6 1.7	3.3 1.6
76.1	x	1/2 (a) □ 15	920N	300 2065	1.50 38.1	2.22 56	2.75 70	—	2.25 57	6.46 164	3.18 81	3.9 1.8	—
			920N	300 2065	1.50 38.1	2.19 56	2.75 70	—	2.25 57	6.46 164	3.18 81	3.9 1.8	—
	x	1 (a) □ 25	920N	300 2065	1.50 38.1	2.07 53	2.75 70	—	2.25 57	6.46 164	3.18 81	3.8 1.7	—
		1 1/4 (a) □ 32	920N	400 2750	1.75 44.5	2.30 58	3.00 76	3.31 84	1.92 49	6.29 160	3.00 76	3.5 1.6	3.2 1.5
		1 1/2 (a) □ 40	920N	400 2750	2.00 50.8	2.28 58	3.00 76	3.31 84	1.92 49	6.29 160	3.25 83	3.5 1.6	3.3 1.5
3 80	x	1/2 (a) □ 15	920N	400 2750	1.50 38.1	2.52 64	3.05 78	—	2.28 58	6.15 156	2.75 70	3.4 1.6	—
			920N	400 2750	1.50 38.1	2.49 63	3.05 78	—	2.28 58	6.15 156	2.75 70	3.4 1.6	—
	x	1 (a) □ 25	920N	400 2750	1.50 38.1	2.38 61	3.06 78	—	2.28 58	6.15 156	2.75 70	3.3 1.6	—
		1 1/4 (a) † □ 32 (b)	920N	400 2750	1.75 44.5	2.55 65	3.25 83	3.56 90	2.28 58	6.15 156	3.00 76	3.8 1.8	3.7 1.8
		1 1/2 (a) † □ 40 (b)	920N	400 2750	2.00 50.8	2.78 71	3.50 89	3.56 90	2.28 58	6.15 156	3.25 83	4.1 1.9	3.8 1.8
2 (a) □ 50	920N	400 2750	2.50 63.5	2.75 70	3.50 89	3.56 90	2.28 58	6.75 172	3.88 99	4.9 2.3	4.6 2.1		
3 1/2 90	x	2 50	920N	400 2750	2.50 63.5	—	—	3.75 95	2.44 62	6.72 171	3.88 99	—	3.8 1.8
4 100	x	1/2 (a) □ 15	920N	400 2750	1.50 38.1	3.03 77	3.56 90	—	2.69 68	7.01 178	2.75 70	3.7 1.8	—
			920N	400 2750	1.50 38.1	3.00 76	3.56 90	—	2.69 68	7.01 178	2.75 70	3.7 1.8	—
	x	1 (a) □ 25	920N	400 2750	1.50 38.1	2.88 73	3.56 90	—	2.69 68	7.01 178	2.75 70	3.6 1.8	—
		1 1/4 (a) † □ 32 (b)	920N	400 2750	1.75 44.5	3.08 78	3.78 96	4.00 102	2.69 68	7.01 178	3.00 76	4.0 1.9	3.6 1.8
		1 1/2 (a) † □ 40 (b)	920N	400 2750	2.00 50.8	3.28 83	4.00 102	4.00 102	2.69 68	7.01 178	3.25 83	4.2 2.0	3.9 1.9
2 (a) † □ 50	920N	400 2750	2.50 63.5	3.25 83	4.00 102	4.00 102	2.69 68	7.01 178	3.88 99	5.0 2.3	4.6 2.1		
2 1/2 (a) † 65	920	400 2750	2.75 69.9	2.88 73	4.00 □ 102	4.00 102	2.69 68	7.34 186	4.63 118	5.8 2.6	5.0 2.3		
76.1 mm	920	400 2750	2.75 69.9	—	—	4.00 102	2.69 68	7.34 186	4.63 118	—	6.4 2.9		
3 (a) † 80	920	400 2750	3.50 88.9	3.31 84	4.50 □ 114	4.12 105	2.69 68	7.73 196	5.12 130	8.4 3.8	6.4 2.9		

TABLE CONTINUED ON PG. 6-3, SEE FOOTNOTES ON PG. 6-5

IMPORTANT NOTES:

Style 920 and Style 920N housings cannot be mated to one another to achieve cross connections.

Hole Cut Piping System

Mechanical-T Bolted Branch Outlet (cont'd)

STYLE 920/920N

Grooved/Female Threaded Outlet

For Complete Information
Request Publication **11.02**

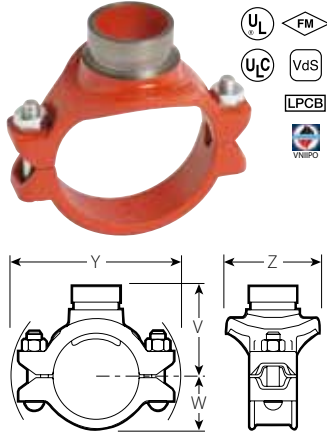

GROOVED OUTLET

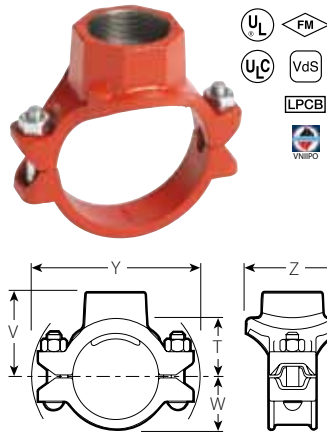

FEMALE THREADED OUTLET

- Provide a direct branch connection at any location where a hole can be cut in the pipe
- A pressure responsive gasket provides the seal
- Pressure rated up to 400 psi/2750 kPa
- Sizes from 2 x 1/2"/50 x 15 mm through 8 x 4"/200 x 100 mm

IMPORTANT NOTES:

Style 920 and Style 920N housings cannot be mated to one another to achieve cross connections.

Size	Style No.	Max. Work Pressure@	Dimensions							Approx. Weight Each			
			Run x Branch Nominal Size Inches mm	920 or 920N	psi kPa	Hole Diameter +0.13 -0.00	T ** Inches mm	V †# Threaded Inches mm	V † Grooved Inches mm	W Inches mm	Y Inches mm	Z Inches mm	Female Threaded Lbs. kg
TABLE CONTINUED FROM PG. 5-2													
108.0 ×	1 1/4 (a) 32	920N	400 2750	1.75 44.5	3.08 78	3.78 96	—	2.63 67	7.64 194	3.05 78	5.0 2.3	—	
	1 1/2 (a) 40	920N	400 2750	2.00 50.8	3.28 83	4.00 102	—	2.63 67	7.64 194	3.25 83	5.0 2.3	—	
	2 (a) 50	920N	400 2750	2.50 63.5	3.25 83	4.00 102	—	2.63 67	7.64 194	4.00 102	4.0 1.9	—	
	76.1 mm	920	400 2750	2.75 69.9	2.88 73	4.00 102	4.00 102	2.63 67	7.64 194	4.29 109	8.0 3.6	—	
	3 (a) 80	920	400 2750	3.50 88.9	3.31 84	4.50 114	—	2.63 67	7.63 194	4.88 124	6.8 3.1	6.5 3.0	
	5 125 ×	1 1/2 (a) 40	920	400 2750	2.00 50.8	4.03 102	4.75 121	4.75 121	3.16 80	9.70 246	3.69 94	7.4 3.4	7.6 3.4
133.0 ×	2 (a) 50	920	400 2750	2.50 63.5	4.00 102	4.75 121	4.75 121	3.16 80	9.70 246	4.38 111	8.2 3.7	8.0 3.6	
	2 1/2 (a) 65	920	400 2750	2.75 69.9	3.63 92	4.75 121	4.75 121	3.16 80	9.70 246	4.63 118	8.3 3.8	7.9 3.6	
	76.1 mm 3/8	920	400 2750	2.75 69.9	—	—	4.75 121	3.16 80	9.70 246	4.63 118	—	8.0 3.6	
	3 (a) 80	920	400 2750	3.50 88.9	3.81 97	5.00 127	4.63 118	3.16 80	9.70 246	5.31 135	8.4 3.8	8.8 4.0	
	139.7 ×	2 50	920N	400 2750	2.50 63.5	3.75 95	4.50 114	—	3.17 81	8.00 203	3.88 99	8.0 3.6	—
		3 80	920	400 2750	3.50 88.9	3.81 97	5.00 127	—	3.00 76	9.46 240	5.31 135	8.0 3.6	—
1 1/2 40		920N	400 2750	2.00 50.8	3.78 96	4.50 114	—	3.30 84	8.23 209	3.25 83	7.0 3.2	—	
2 50		920N	400 2750	2.50 63.5	3.75 95	4.50 114	—	3.30 84	8.23 209	3.88 99	9.0 4.1	—	
76.1 mm		920	400 2750	2.75 69.9	3.63 92	4.75 121	—	3.13 80	9.85 250	4.63 118	8.8 4.0	—	
76.1 mm		920	400 2750	3.50 88.9	—	—	4.63 118	3.16 80	9.70 246	5.31 135	—	11.0 5.0	
6 150 ×	3 88.9	920	400 2750	3.50 88.9	3.81 96.80	5.00 127	4.63 118	3.16 80	9.85 250	5.38 137	14.0 6.4	14.2 6.4	
	1 1/4 (a) 32 (b)	920N	400 2750	1.75 44.5	4.43 112	—	—	3.79 96	9.15 232	3.25 83	—	4.8 2.2	
	1 1/2 (a) 40 (b)	920N	400 2750	2.00 50.8	4.40 112	5.13 130	5.13 130	3.79 96	9.15 232	3.25 83	5.4 2.4	5.1 2.3	
	2 (a) 50	920N	400 2750	2.50 63.5	4.38 111	5.13 130	5.13 130	3.79 96	9.15 232	3.88 99	6.0 2.7	5.6 2.5	
	2 1/2 (a) 65	920	400 2750	2.75 69.9	4.01 110	5.13 130	5.12 130	3.69 94	10.51 267	4.63 118	8.3 3.8	7.6 3.4	
	76.1 mm 3/8	920	400 2750	2.75 69.9	—	—	5.21 132	3.69 94	10.51 267	4.63 118	—	8.4 3.8	
	3 (a) 80	920	300 2065	3.50 88.9	4.31 110	5.50 140	5.13 130	3.69 94	10.51 267	5.31 135	9.9 4.5	8.4 3.8	
	4 (a) 100	920	300 2065	4.50 114.3	3.81 97	5.75 146	5.38 137	3.69 94	10.51 267	6.25 159	10.1 4.6	10.1 4.6	
	159.0 ×	1 1/4 32	920N	400 2750	1.75 44.5	4.43 113	5.13 130	—	3.63 92	9.40 239	3.25 83	9.0 4.1	8.7 4.0
		1 1/2 (a) 40	920N	400 2750	2.00 50.8	4.41 112	5.13 130	—	3.63 92	9.40 239	3.25 83	7.8 3.5	—
2 (a) 50		920N	400 2750	2.50 63.5	4.38 111	5.13 130	—	3.63 92	9.40 239	3.88 99	8.0 3.6	—	
76.1 mm		920	400 2750	2.75 69.9	4.38 111	5.50 140	5.13 130	3.63 92	9.40 239	4.63 118	9.5 4.3	9.5 4.3	
3 80		920	400 2750	3.50 88.9	4.31 110	5.50 140	5.13 130	3.63 92	9.40 239	5.31 135	8.1 3.7	14.0 6.4	
108.1 mm		920	400 2750	4.50 114.3	—	—	5.38 137	3.63 92	9.40 239	6.12 155	—	10.0 4.5	
4 100		920	400 2750	4.50 114.3	3.81 96.80	5.75 146	—	3.63 92	9.40 239	6.25 159	18.0 8.2	—	
165.1 ×		1 25	920N	400 2750	1.50 38.1	3.88 99	4.56 116	—	3.79 96	9.34 237	2.75 70	8.0 3.6	—
		1 1/4 32	920N	400 2750	1.75 44.5	4.43 113	5.13 130	—	3.79 96	9.34 237	3.25 83	8.4 3.8	—
		1 1/2 (a) 40	920N	400 2750	2.00 50.8	4.41 112	5.13 130	—	3.79 96	9.34 237	3.25 83	8.4 3.8	—

TABLE CONTINUED ON PG. 6-4, SEE FOOTNOTES ON PG. 6-5

Hole Cut Piping System

Mechanical-T Bolted Branch Outlet (cont'd)

STYLE 920/920N

Grooved/Female Threaded Outlet

For Complete Information
Request Publication 11.02

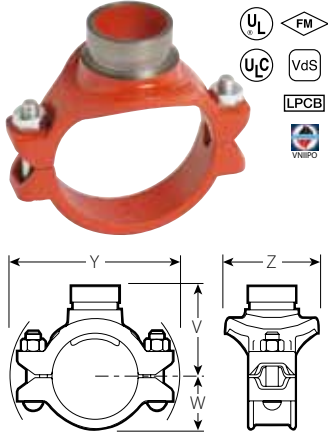

GROOVED OUTLET

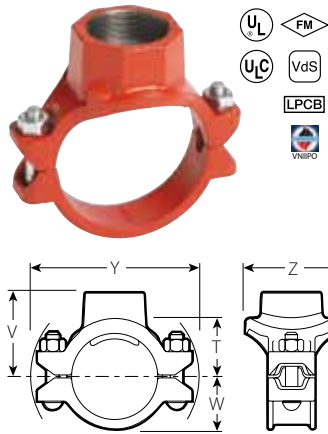

FEMALE THREADED OUTLET

- Provide a direct branch connection at any location where a hole can be cut in the pipe
- A pressure responsive gasket provides the seal
- Pressure rated up to 400 psi/2750 kPa
- Sizes from 2 x ½"/50 x 15 mm through 8 x 4"/200 x 100 mm

IMPORTANT NOTES:

Style 920 and Style 920N housings cannot be mated to one another to achieve cross connections.

Size		Style No.	Max. Work Pressure [@]	Dimensions							Approx. Weight Each	
Run x Branch Nominal Size	Inches	920 or 920N	psi	Hole Diameter +0.13 -0.00	T ** Inches	V †# Threaded Inches	V ‡ Grooved Inches	W Inches	Y Inches	Z Inches	Female Threaded Lbs. kg	Grooved Lbs. kg
TABLE CONTINUED FROM PG. 5-3												
165.1	2 (a) †	920N	400	2.50	4.38	5.13 ^α	—	3.79	9.34	3.88	8.5	—
	50		2750	63.5	111	130		96	237	99	3.9	
	2½ † ^α	920	400	2.75	4.01	5.13	—	3.63	10.51	4.63	8.6	7.6
	65		2750	69.9	110	130		92	267	118	3.9	3.4
	76.1 mm	920	400	2.75	4.01	5.13	5.21 ^α	3.63	10.51	4.63	8.6	7.6
			2750	69.9	110	130	132	92	267	118	3.9	3.4
8	3 (a) †*	920	400	3.50	4.31	5.50	5.13 ^α	3.63	10.51	5.31	10.2	8.4
	80		2750	88.9	110	140	130	92	267	135	4.6	3.8
	4 (a) † ^α	920	400	4.50	3.81	5.75	5.38	3.63	10.51	6.25	10.5	8.4
	100		2750	114.3	97	146	137	92	267	159	4.8	3.8
	76.1 mm	920	400	2.75	5.44	6.19	6.25 ^α	4.81	12.42	4.50	11.6	11.6
			2750	69.9	138	157	159	122	316	114	5.3	5.3
200	2½ (a) †	920	400	2.75	5.07	6.19	6.19	4.81	12.42	4.50	11.6	11.6
	65		2750	69.9	129	157	157	122	316	114	5.3	5.3
	76.1 mm	920	400	2.75	—	—	6.25	4.81	12.42	4.56	—	11.6
			2750	69.9	—	—	159	122	316	116	—	5.3
	3 (a) † ^α	920	300	3.50	5.31	6.50	6.50	4.81	12.42	5.31	12.6	11.6
		2065	88.9	135	165	165	122	316	135	5.7	5.3	
4 (a) † ^α	100	920	300	4.50	4.81	6.75	6.38	4.81	12.42	6.25	15.3	12.5
			2065	114.3	122	171	162	122	316	159	6.9	5.7

** Center of run to engaged pipe end, female threaded outlet only (dimensions approximate).

† Available with grooved or female threaded outlet. Specify choice on order.

‡ Center of run to end of fitting.

Female threaded outlets are available to NPT and BSPT specifications.

@ These pressure ratings are general guidelines. Please consult Publication 10.01 for specific pressure ratings by type of pipe.

(a) British Standard female pipe threaded outlet is available as listed. Specify "BSPT" clearly on order.

(b) For 76.1 mm threaded outlet, specify 2½" BSPT clearly on order.

§ VdS approved for fire protection services.

α LPCB approved for fire protection services.

* Approved for use in China by Tianjin Approvals Company.

Mechanical-T Bolted Branch Outlet

STYLE 920 CROSS

For Complete Information
Request Publication 11.03

Mechanical-T Cross assemblies can be achieved with the use of two Style 920 or 920N of the same run size and the same or differing outlet size. Most sizes of Mechanical-T are available with either grooved or female threaded outlets. Your choice must be specified on each order.

NOTE: Style 920 and Style 920N housings cannot be mated to achieve cross connections.



Hole Cut Piping System

Vic-Let Strapless Outlet

STYLE 923

For Complete Information
Request Publication **11.05**



TYPICAL 4-8"/100-200 mm
IPS SIZES



TYPICAL 10"/250 mm
AND LARGER SIZES



- Fast, easy pipe outlet eliminates the need for welded outlets
- Pressure rated up to 300 psi/2065 kPa
- Standard wall pipe steel pipe for sizes 4-8"/100-200 mm and Schedules 10 - 40
steel pipe for sizes 10"/250 mm and larger

Size Run × Branch Nominal Size Inches mm	Max. Work Pressure psi * kPa	Dimensions						Approx. Weight Each Lbs. kg
		Hole Dimensions		Vic-Let Dimensions				
		Hole Saw Size Inches mm	Max. Perm. Dia. Inches mm	T ** Inches mm	X Inches mm	Y *** Inches mm		
4 - 8 100 - 200 ×	1/2	300	1.50	1.56	2.47	3.00	3.09	1.9
	15	2065	38.1	39.6	63	76	78	0.9
	3/4	300	1.50	1.56	2.44	3.00	3.09	1.6
10 - larger 250 - larger ×	15	2065	38.1	39.6	62	76	78	0.7
	3/4	300	1.50	1.56	2.44	3.00	3.00	1.6
	20	2065	38.1	39.6	62	76	76	0.7

* On schedule 40 pipe 4-8"/100-200 mm and Schedule 10 - 40 for sizes 10"/250 mm and larger. Minimum 0.165"/4.2 mm, maximum 0.375"/9.5 mm wall thickness on large pipe or flat plate. Pressure rating is for Vic-Let outlet only, pipe used must also be rated at this pressure or higher. Pressure rating is 200 psi/1375 kPa for standard wall aluminum pipe.

** Inside wall of run to engaged pipe end.

*** Width of collar is as supplied, width assembled changes due to collar deformation at assembly.

IMPORTANT NOTES:

Flow Data: Flow area equivalent to 3/4"/20 mm pipe. Accepts 7/16"/11 mm diameter probe.

Warning: Always depressurize system and drain before disassembly.

Due to deformation of the collar, Vic-Let outlet should not be re-used after initial installation.

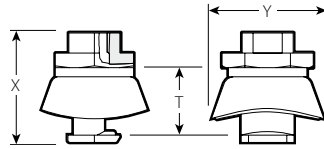

TYPICAL 4-8"/100-200 mm IPS SIZES

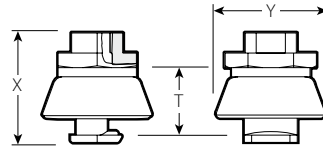

TYPICAL 10"/250 mm AND LARGER SIZES

Hole Cut Piping System

Vic-O-Well Strapless Thermometer Outlet

STYLE 924

For Complete Information
Request Publication 11.06



TYPICAL 4-8"
100-200 mm IPS SIZES



TYPICAL 10"/250 mm
AND LARGER SIZES

Size	Max. Work Pressure	Dimensions					Approx. Weight Each
		Hole Dimensions		Vic-O-Well Dimensions			
		Hole Saw Size	Max. Perm. Dia.	T**	X	Y***	
Run x Branch Nominal Size Inches mm	psi* kPa	Inches mm	Inches mm	Inches mm	Inches mm	Inches mm	Lbs. kg
4 - 8 for 6" Stem † 100 - 200 for 150 mm Stem	300 2065	1.50 38.1	1.56 39.6	3.00 76	7.09 180	3.09 78	2.4 1.1
10 - larger for 6" Stem † 250 - larger for 150 mm Stem	300 2065	1.50 38.1	1.56 39.6	3.00 76	7.09 180	3.09 78	2.3 1.0

* On schedule 40 pipe 4-8"/100-200mm and Schedule 10 - 40 for sizes 10"/250mm and larger. Minimum 0.165"/4.2 mm, maximum 0.375"/9.5 mm wall thickness on large pipe or flat plate. Pressure rating is for Vic-O-Well outlet only, pipe used must also be rated at this pressure or higher. Pressure rating is 200psi/1375kPa for standard wall aluminum pipe.

** Inside wall of run to end of probe.

*** Width of collar is as supplied, width assembled changes due to collar deformation at assembly.

† 1 1/4" outlet - 1 1/4" - NEF18-2B

IMPORTANT NOTES:

Flow Data: Flow characteristics for Vic-O-Well Style 924 are superior to standard welded or threaded outlets of equivalent branch sizes.

Warning: Always depressurize system and drain before disassembly.

Due to deformation of the collar, Vic-O-Well thermometer should not be re-used after initial installation.

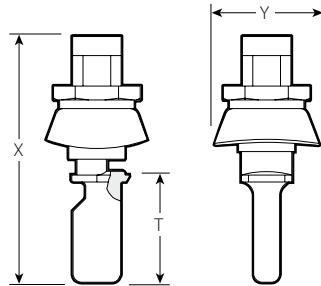

TYPICAL 4-8"/100-200 mm IPS SIZES

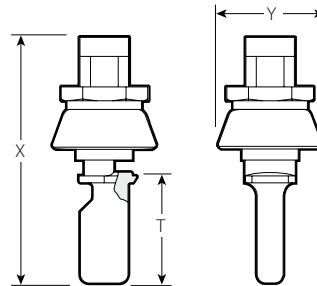

TYPICAL 10"/250 mm AND LARGER SIZES

- Fast, easy connection combining features of thermowell and strapless mechanical outlet
- Main body is machined internally to standard thread well dimension 1 1/4"/32mm outlet - 1 1/4" - NEF18 - 2B
- Eliminates the need for welded outlets
- Ideal for a variety of industrial glass thermometers with a 6"/150mm nominal bulb length
- Provides 2 1/2"/65 mm for insulation and lagging
- Pressure rated up to 300 psi/2065 kPa on steel pipe
- Sizes from 4-8"/100-200 mm through 10"/250 mm and larger

Plain End Piping System

The Victaulic plain end piping method is ideal for maintenance and repairs as well as new systems such as roof drains, slurries, tailings and oil field services. Roust-A-Bout couplings and plain end fittings are UL and ULC Listed for fire protection services.

Victaulic plain end couplings are primarily designed for use on standard weight steel pipe (Schedule 40), but may be used on lightwall steel or other metallic pipe such as aluminum or stainless steel. They are not intended for use on plastic pipe, plastic-coated pipe or brittle pipe, such as asbestos cement or cast iron. Nor are they intended for use on pipe with a surface hardness greater than 150 Brinell.



Roust-A-Bout® Coupling

STYLE 99, PG. 7-3

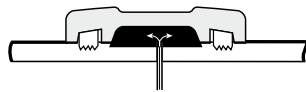

All illustrations shown are exaggerated for clarity

RELIABLE AND LEAK-FREE

- Pressure responsive gasket design seals under pressure or vacuum
- Standard gaskets cover most services
- Special gaskets available for many chemical services

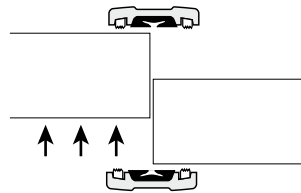

UNION AT EVERY JOINT

- Permits easy access to existing lines
- Removal of only two couplings permits removal of pipe, valves or equipment
- Permits rotation of pipe

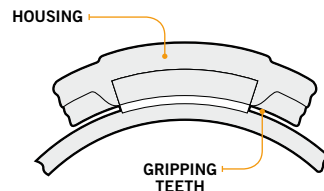

JAWS CONFORM TO PIPE

- Roust-A-Bout jaws are circumferentially curved to match pipe contour
- Provide greater pipe contact for positive grip
- Pinned into housing to prevent loss before installation

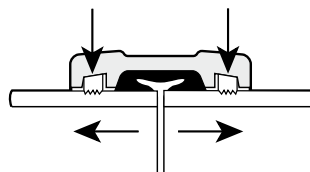

ROUST-A-BOUT JAWS RIGID TO GRIP PIPE

- Set at right angle to the pipe for gripping efficiency

Plain End Piping System

Plain End Fittings Required Tangent Length

- Use chart to the right to figure out tangent length
- For use with Style 99 Roust-A-Bout couplings
- With plain end or beveled end pipe
- Cast of ductile iron and finished with a dip coat of enamel
- Request Publication 14.04

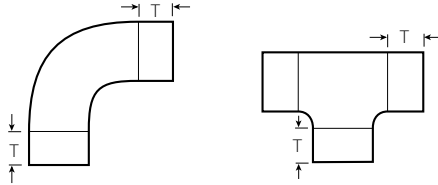

Size		Tangent Length
Nominal Size Inches mm	Actual Outside Dia. Inches mm	T Minimum Inches mm
1½ 40	1.900 48.3	1.50 38
2 50	2.375 60.3	1.75 45
2½ 65	2.875 73.0	1.75 45
3 80	3.500 88.9	1.75 45
3½ 90	4.000 101.6	1.75 45
4 100	4.500 114.3	2.00 51
5 125	5.563 141.3	2.13 54

Size		Tangent Length
Nominal Size Inches mm	Actual Outside Dia. Inches mm	T Minimum Inches mm
165.1 mm	6.500 165.1	2.13 54
6 150	6.625 168.3	2.13 54
8 200	8.625 219.1	2.25 57
10 250	1.750 273.0	2.25 57
12 300	12.750 323.9	2.25 57
14 350	14.000 355.6	2.25 57
16 400	16.000 406.4	2.25 57

Fittings

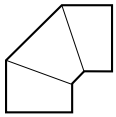

90° Elbow
Seg. Welded Steel
NO. 10P, PG. 7-4

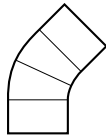

45° Elbow
Seg. Welded Steel
NO. 11P, PG. 7-4

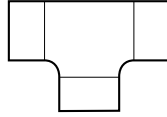

Tee
NO. 20P, PG. 7-5

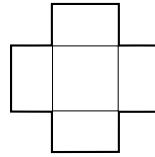

Cross
NO. 35P, PG. 7-5

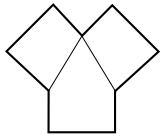

True Wye
NO. 33P, PG. 7-5



Steel Bull Plug
NO. 61P, PG. 7-5

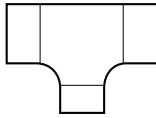

Reducing Tee
NO. 25P, PG. 7-6

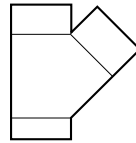

45° Lateral
NO. 30P, PG. 7-6

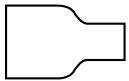

Swaged Nipple
NO. 53P, PG. 7-7



Adapter Nipple
Plain End × Thd.
NO. 40P, PG. 7-8



Adapter Nipple
Plain End × Bev.
NO. 42P, PG. 7-8



Adapter Nipple
Plain End × Grv.
NO. 43P, PG. 7-8

PRODUCTS

- 1-1 Couplings
- 2-1 Fittings
- 3-1 Valves
- 4-1 Accessories
- 5-1 Advanced Groove System
- 6-1 Hole Cut Piping System
- 7-1 Plain End Piping System**
- 8-1 Grooved System for Stainless Steel Pipe
- 9-1 Pressfit System for Stainless Steel Pipe
- 10-1 Plain End Piping System for HDPE Pipe
- 11-1 Grooved Copper
- 12-1 PermaLynx System for Copper Tube
- 13-1 Grooved AWWA Ductile Iron Pipe
- 14-1 Victaulic Depend-O-Lok® System
- 15-1 Aquamine Reusable PVC Products
- 16-1 Gaskets
- 17-1 Pipe Preparation Tools
- 18-1 Product Index
- 19-1 Piping Software

Plain End Piping System – Couplings

Roust-A-Bout Coupling

STYLE 99

For Complete Information Request Publication **14.02**



- Specifically designed for plain end steel and stainless steel pipe
- Gripping teeth provide a strong component for joining plain and beveled end (including Schedule 80 steel pipe)
- Not to be used on plastic pipe, pipe with brittle linings, cast or ductile iron pipe nor any pipe with a surface hardness greater than 150 Brinell
- Pressure rated up to 750 psi/5175 kPa
- Sizes from 1 – 18”/25 – 450 mm

Size		Max. Work Pressure*	Max. End Load*	Dimensions			Approx. Weight Each
Nominal Size Inches mm	Actual Outside Dia. Inches mm	psi kPa	Lbs. kg	X Inches mm	Y Inches mm	Z Inches mm	Lbs. kg
1 25	1.315 33.7	600 4130	800 3560	2.56 65	4.25 108	2.25 57	1.7 0.8
1½ 40	1.900 48.3	750 5175	2100 9345	3.25 83	5.50 140	2.88 73	3.6 1.6
2 50	2.375 60.3	750 5175	3300 14685	3.75 95	6.75 171	3.38 86	5.3 2.4
2½ 65	2.875 73.0	600 4130	3890 17310	4.25 108	7.13 181	3.38 86	5.7 2.5
76.1 mm	3.000 76.1	400 2700	2825 12500	4.69 119	6.25 159	2.75 70	4.4 2.0
3 80	3.500 88.9	600 4130	5770 25676	5.00 127	8.50 216	3.38 86	8.7 3.9
3½ 90	4.000 101.6	500 3450	6280 27946	5.50 140	9.25 235	3.63 92	10.6 4.8
4 100	4.500 114.3	450 3100	7155 31840	6.13 156	10.00 254	4.00 102	12.8 5.8
5 125	5.563 141.3	350 2400	8500 37825	7.25 184	11.38 289	4.38 111	17.3 7.8
139.7 mm	5.500 139.7	250 1700	5940 26440	7.80 200	10.75 260	3.19 81	9.0 4.1
6 150	6.625 168.3	300 2065	10340 46013	8.50 216	13.38 340	4.38 111	23.2 10.5
165.1 mm	6.500 165.1	300 2065	9955 44300	8.38 213	13.25 337	4.38 111	22.2 10.1
8 200	8.625 219.1	250 1700	14600 64970	10.88 276	14.38 365	5.00 127	37.2 16.9
10 250	10.750 273.0	250 1700	22700 101015	13.38 340	16.38 416	5.00 127	48.2 21.9
12 300	12.750 323.9	250 1700	31900 141955	15.50 394	19.63 499	5.13 130	60.0 27.2
14 350	14.000 355.6	200 1400	30800 137060	16.75 425	20.75 527	5.38 137	89.0 40.4
16 400	16.000 406.4	150 1000	30200 134390	19.00 483	22.63 575	5.38 137	105.0 47.6
18 450	18.000 457.0	150 1000	38200 169990	21.00 533	23.50 597	5.38 137	125.0 56.7

* Working Pressure and End Load are total, from all internal and external loads, based on coupling properly assembled, with bolts fully torqued to listed specifications, on plain end or beveled end standard weight (ANSI) steel pipe and Victaulic plain end fittings. Couplings are designed to be used with plain end pipe and Victaulic plain end fittings only.

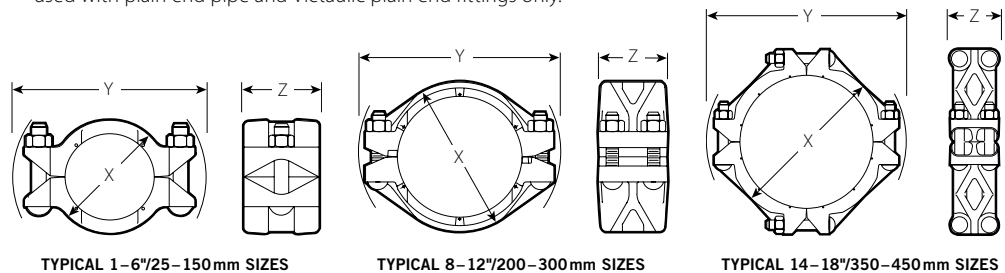

Plain End Piping System – Fittings

Elbow

NO. 10P 90° Elbow
NO. 11P 45° Elbow
 (Segmentally welded steel #)

For Complete
 Information Request
 Publication **14.04**

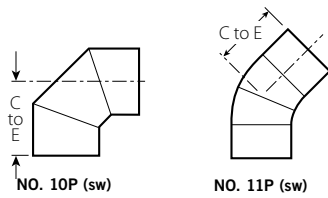

Size		No. 10P 90° Elbow		No. 11P 45° Elbow	
Nominal Size Inches mm	Actual Outside Dia. Inches mm	C to E Inches mm	Approx. Wgt. Each Lbs. kg	C to E Inches mm	Approx. Wgt. Each Lbs. kg
1 25	1.315 33.7	2.25 (d) 57	0.6 0.3	1.75 (d) 44	0.6 0.3
1½ 40	1.900 48.3	4.00 102	1.4 0.6	2.88 73	1.0 0.5
2 50	2.375 60.3	4.75 121	2.9 1.3	3.13 80	1.4 0.6
2½ 65	2.875 73.0	5.50 140	3.9 1.8	3.50 89	2.3 1.0
3 80	3.500 88.9	6.25 159	6.15 2.8	3.75 95	4.3 2.0
3½ 90	4.000 101.6	7.00 178	7.0 3.2	4.00 102	5.5 2.5
4 100	4.500 114.3	7.75 197	9.9 4.5	4.25 108	7.0 3.2
5 125	5.563 141.3	9.50 (d) 241	20.4 9.3	5.13 130	18.0 8.2
6 150	6.625 168.3	6.50 (d) 165	20.4 9.3	3.50 (d) 89	11.9 5.4
8 200	8.625 219.1	10.00 254	42.0 19.1	6.00 152	28.5 12.9
10 250	10.750 273.0	11.50 292	50.0 22.7	6.50 165	41.0 18.6
12 300	12.750 323.9	13.50 343	156.0 70.8	7.00 178	57.8 26.2

Segmentally welded steel except those marked (d) which are ductile iron.

Plain End Piping System – Fittings

Tee, Cross, True Wye, and Bull Plug

NO. 20P Tee

NO. 35P Cross

NO. 33P True Wye

NO. 61P Bull Plug

(Segmentally welded steel #)

For Complete Information
Request Publication 14.04

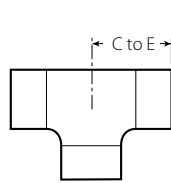

NO. 20P

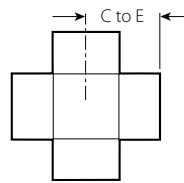

NO. 35P

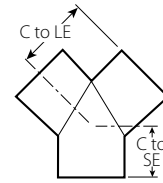

NO. 33P

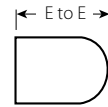

NO. 61P

Size		No. 20P Tee		No. 35P Cross		No. 33P True Wye			No. 61P Steel Bull Plug	
Nominal Size Inches mm	Actual Outside Dia. Inches mm	C to E Inches mm	Approx. Wgt. Each Lbs. kg	C to E Inches mm	Approx. Wgt. Each Lbs. kg	C to LE Inches mm	C to SE Inches mm	Approx. Wgt. Each Lbs. kg	E to E Inches mm	Approx. Wgt. Each Lbs. kg
1 25	1.315 33.7	2.25 (d) 57	1.0 0.5	3.25 83	1.7 0.8	3.25 83	2.25 57	1.1 0.5	3.00 76	0.7 0.3
1½ 40	1.900 48.3	2.75 70	1.7 0.8	4.00 102	3.5 1.6	4.00 102	2.75 70	1.8 0.8	3.50 89	1.2 0.5
2 50	2.375 60.3	3.25 83	3.0 1.4	4.25 108	5.2 2.4	4.25 108	2.75 70	2.9 1.3	4.00 102	2.0 0.9
2½ 65	2.875 73.0	3.75 95	6.8 3.1	4.75 121	5.4 2.4	4.75 121	3.00 76	9.0 4.1	5.00 127	3.0 1.4
3 80	3.500 88.9	4.25 108	9.0 4.1	5.13 130	8.5 3.9	5.13 130	3.25 83	8.5 3.9	6.00 152	4.5 2.0
3½ 90	4.000 101.6	5.50 140	12.5 5.7	5.50 140	9.0 4.1	5.50 140	3.50 89	10.0 4.5	6.50 165	6.0 2.7
4 100	4.500 114.3	5.00 (d) 127	11.9 5.4	5.88 149	10.8 4.9	5.88 149	3.75 95	14.0 6.4	7.00 178	7.5 3.4
5 125	5.563 141.3	6.88 175	17.1 7.8	6.88 175	20.0 9.1	6.88 175	4.00 102	21.6 9.8	8.50 216	11.5 5.2
6 150	6.625 168.3	6.50 (d) 165	29.5 13.3	7.63 194	30.0 13.6	7.63 194	4.50 114	31.2 14.2	10.00 254	17.0 7.7
8 200	8.625 219.1	10.00 254	71.5 32.4	10.00 254	66.4 30.1	10.00 254	6.00 152	36.0 16.3	11.00 279	29.0 13.2
10 250	10.750 273.0	11.50 292	116.0 52.6	11.50 292	103.0 46.7	11.50 292	6.50 165	52.0 23.6	13.00 330	48.0 21.8
12 300	12.750 323.9	13.50 343	120.0 54.4	13.50 343	158.0 71.7	13.50 343	7.00 178	81.2 36.8	14.00 356	60.0 27.2

Segmentally welded steel except those marked (d) which are ductile iron.

Plain End Piping System – Fittings

Reducing Tee

NO. 25P
(Ductile Iron)

For Complete Information
Request Publication **14.04**

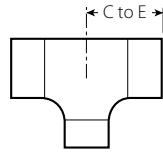

NO. 25P

Size			No. 25P Reducing Tee			
Nominal Size Inches mm			C to E Inches mm	Approx. Weight Each Lbs. kg		
1 1/2 40	×	1 1/2 40	×	1 25	4.00 102	2.2 1.0
2 50	×	2 50	×	1 25	4.25 108	2.9 1.3
				1 1/2 40	4.25 108	3.1 1.4
3 80	×	3 80	×	1 25	5.13 130	6.7 3.0
				1 1/2 40	5.13 130	6.9 3.1
				2 50	5.13 130	7.1 3.2
4 100	×	4 100	×	1 25	5.88 149	10.9 4.9
				1 1/2 40	5.88 149	11.1 5.0
				2 50	5.88 149	11.3 5.1
				2 1/2 65	5.88 149	11.6 5.3
				3 80	5.88 149	11.9 5.4
6 150	×	6 150	×	2 50	7.63 194	24.7 11.2
				3 80	7.63 194	25.4 11.5
				4 100	7.63 194	26.2 11.9
				8 200	10.00 254	42.0 15.2
				3 80	10.00 254	44.0 20.0
				4 100	10.00 254	46.0 20.9
10 250	×	10 250	×	4 100	11.50 292	74.0 33.6
				6 150	11.50 292	78.0 35.4
				8 200	11.50 292	86.0 39.0
				12 300	13.50 343	112.0 50.8
12 300	×	12 300	×	8 200	13.50 343	118.0 53.5
				10 250	13.50 343	130.0 59.0
				12 300	13.50 343	130.0 59.0

45° Lateral

NO. 30P
(Segmentally Welded Steel)

For Complete Information
Request Publication **14.04**

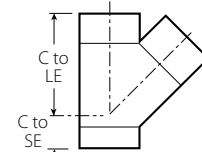

NO. 30P

Size		No. 30P 45° Lateral		
Nominal Size Inches mm	Actual Outside Diameter Inches mm	C to LE Inches mm	C to SE Inches mm	Approx. Weight Each Lbs. kg
1 25	1.315 33.7	5.00 127	2.25 57	3.5 1.6
1 1/2 40	1.900 48.3	6.25 159	2.75 70	3.5 1.6
2 50	2.375 60.3	7.25 184	2.75 70	5.1 2.3
2 1/2 65	2.875 73.0	7.75 197	3.00 76	9.3 4.2
3 80	3.500 88.9	8.75 222	3.25 83	12.8 5.8
3 1/2 90	4.000 101.6	10.00 254	3.50 89	20.0 9.1
4 100	4.500 114.3	10.75 263	3.75 95	19.0 8.6
5 125	5.563 141.3	12.75 324	4.00 102	30.0 13.6
6 150	6.625 168.3	14.00 356	4.50 114	43.3 19.6
8 200	8.625 219.1	18.00 457	6.00 152	92.0 41.7
10 250	10.750 273.0	20.75 527	6.50 165	106.0 48.1
12 300	12.750 323.9	24.50 622	7.00 178	167.0 75.8

Plain End Piping System – Fittings

Swaged Nipple

NO. 53P
(Steel)

For Complete Information
Request Publication **14.04**

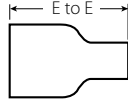

NO. 53P

Size		No. 53P Swaged Nipple	
Nominal Size Inches		E to E Inches	Approx. Weight Each Lbs.
mm		mm	kg
1½	× 1	4.50	1.2
40	25	114	0.6
2	× 1	6.50	2.0
50	25	165	0.9
	1½	6.50	2.0
	40	165	0.9
2½	× 1	7.00	3.0
65	25	178	1.4
	1½	7.00	3.0
	40	178	1.4
	2	7.00	3.0
	50	178	1.4
3	× 1	8.0	4.5
80	25	203	2.0
	1½	8.0	4.5
	40	203	2.0
	2	8.00	4.5
	50	203	2.0
	2½	8.00	4.5
	65	203	2.0
3½	× 3	8.00	6.8
90	80	203	3.1
4	× 1	9.00	7.5
100	25	229	3.4
	1½	9.00	7.5
	40	229	3.4
	2	9.00	7.5
	50	229	3.4
	2½	9.00	7.5
	65	229	3.4
	3	9.00	7.5
	80	229	3.4
	3½	9.00	7.5
	90	229	3.4
5	× 2	11.00	11.5
125	50	279	5.2
	3	11.00	11.5
	80	279	5.2
	4	11.00	11.5
	100	279	5.2

Size		No. 53P Swaged Nipple	
Nominal Size Inches		E to E Inches	Approx. Weight Each Lbs.
mm		mm	kg
6	× 1	12.00	16.0
150	25	305	7.3
	1½	12.00	16.0
	40	305	7.3
	2	12.00	17.0
	50	305	7.7
	2½	12.00	17.0
	65	305	7.7
	3	12.00	17.0
	80	305	7.7
	3½	12.00	17.0
	90	305	7.7
	4	12.00	17.0
	100	305	7.7
	5	12.00	17.0
	125	305	7.7
8	× 3	13.00	29.0
200	80	330	13.2
	4	13.00	29.0
	100	330	13.2
	5	13.00	29.0
	125	330	13.2
	6	13.00	48.0
	150	330	21.8
10	× 3	15.00	48.0
250	80	381	21.8
	4	15.00	48.0
	100	381	21.8
	6	15.00	48.0
	150	381	21.8
	8	15.00	48.0
	200	381	21.8
12	× 6	16.00	59.0
300	150	406	26.8
	8	16.00	59.0
	200	406	26.8
	10	16.00	59.0
	250	406	26.8

Plain End Piping System – Fittings

Adapter Nipple

NO. 40P Plain End × Thd.

NO. 42P Plain End × Bev.

NO. 43P Plain End × Grv.

(Steel)

For Complete Information
Request Publication **14.04**

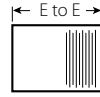

NO. 40P

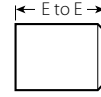

NO. 42P

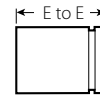

NO. 43P

Size		Dimensions		Approx. Weight Each
Nominal Size Inches mm	Actual Outside Diameter Inches mm	E to E Inches mm		Lbs. kg
1	1.315	3.00		0.9
25	33.7	76		0.4
1 ½	1.900	4.00		0.9
40	48.3	102		0.4
2	2.375	4.00		1.2
50	60.3	102		0.5
2 ½	2.875	4.00		1.9
65	73.0	102		0.9
3	3.500	4.00		2.5
80	88.9	102		1.1
4	4.500	6.00		5.4
100	114.3	152		2.5
6	6.625	6.00		9.4
150	168.3	152		4.3

Grooved System for Stainless Steel Pipe

- Fast, easy and reliable method for joining Sch. 5S, 10S or 40S stainless pipe
- Fittings are supplied with grooves, ready to install
- Couplings available for rigid or flexible joints



Couplings

Rigid Coupling
STYLE 489, PG. 8-3



Rigid Coupling
STYLE 89, PG. 8-4
AGS STYLE W89, PG. 5-4



Flexible Coupling
STYLE 77S, PG. 8-5



Flexible Coupling
STYLE 475, PG. 8-6



Vic-Flange Adapter
ANSI Class 150
STYLE 441, PG. 8-7



Grooved System for Stainless Steel Pipe

Stainless Steel Sch. 10S Fittings



90° Elbow
NO. 410SS,
PG. 8-11



45° Elbow
NO. 411SS,
PG. 8-11

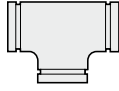

Tee
NO. 420SS,
PG. 8-11

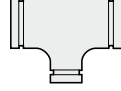

Reducing Tee
NO. 425SS,
PG. 8-12



Concentric Reducer
NO. 450SS,
PG. 8-12

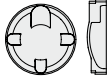

Cap
NO. 460SS,
PG. 8-11

PRODUCTS

- 1-1 Couplings
- 2-1 Fittings
- 3-1 Valves
- 4-1 Accessories
- 5-1 Advanced Groove System
- 6-1 Hole Cut Piping System
- 7-1 Plain End Piping System
- 8-1 Grooved System for Stainless Steel Pipe**
- 9-1 Pressfit System for Stainless Steel Pipe
- 10-1 Plain End Piping System for HDPE Pipe
- 11-1 Grooved Copper
- 12-1 PermaLynx System for Copper Tube
- 13-1 Grooved AWWA Ductile Iron Pipe
- 14-1 Victaulic Depend-O-Lok® System
- 15-1 Aquamine Reusable PVC Products
- 16-1 Gaskets
- 17-1 Pipe Preparation Tools
- 18-1 Product Index
- 19-1 Piping Software

GROOVED SYSTEM FOR STAINLESS STEEL PIPE

Valves

Butterfly Valve
SERIES 763, PG. 8-13



Swinger Check Valve
SERIES 712S, PG. 8-15



Vic-Ball Valve
SERIES 726S, PG. 8-16



Grooved System for Stainless Steel Pipe – Couplings

Rigid Coupling

STYLE 489

For Complete Information
Request Publication 17.25



GROOVED SYSTEM FOR STAINLESS STEEL PIPE

- CF8M stainless steel for corrosion resistance and strength
- Provides an essentially rigid joint
- Pressure rated up to 1200psi/4136kPa for Schedule 40S duplex or super duplex, 600 psi/ 4136 kPa for Schedule 40S, 300 psi/2065 kPa for Schedule 10S, and 200 psi/ 1375 kPa for Schedule 5S; For specific pressure ratings by size and schedule, please refer to Publication 17.25
- Sizes from 1½–12¼/40–300 mm

Size		Max. End Load *				Allow. Pipe End Sep. *	Dimensions			Approx. Wgt. Each
Nominal Size Inches mm	Actual Outside Dia. Inches mm	Lbs. N					Inches mm	X Inches mm	Y Inches mm	Z Inches mm
		Schedule 40S	Schedule 40††	Schedule 10S	Schedule 5S					
1½ 40	1.900	1700	–	850	570	0.05	2.86	4.42	1.84	1.6
	48.3	7565	–	3783	2537	1.3	73	118	47	0.7
2 50	2.375	2660	–	1330	890	0.05	3.34	5.19	1.86	1.6
	60.3	11837	–	5919	3961	1.3	85	132	47	0.7
2½ 65	2.875	3900	–	1950	1300	0.05	3.92	5.62	1.86	1.9
	73.0	17355	–	8678	5785	1.3	100	143	47	0.9
76.1 mm	3.000	4240	–	2120	1415	0.05	4.02	5.72	1.86	2.0
	76.1	18868	–	9434	6297	1.3	102	145	47	0.9
3 80	3.500	5775	–	2890	1925	0.05	4.54	6.78	1.86	2.8
	88.9	25699	–	12861	8566	1.3	115	172	47	1.3
4 100	4.500	9540	–	4775	3180	0.19	5.77	7.90	2.07	4.0
	114.3	42453	–	21249	14151	4.8	147	201	53	1.8
139.7 mm	5.500	14250	1200††	7130	4750	0.25	7.07	11.13	2.38	12.0
	139.7	63413	8273	31729	21138	6.4	180	283	60	5.5
6 150	6.625	20680	41370††	10340	6895	0.25	8.16	12.68	2.50	15.5
	168.3	92026	184030	46015	30685	6.4	207	321	64	7.0
165.1 mm	6.500	19910	1200††	9955	6640	0.25	8.16	12.68	2.50	15.5
	165.1	88600	8273	44300	29548	6.4	207	321	64	7.0
8 200	8.625	35055	70110††	17530	11685	0.25	10.63	15.00	2.75	24.0
	219.1	155995	311870	78010	52000	6.4	270	381	70	10.9
216.3 mm	8.515	34175	–	17090	11390	0.25	10.63	15.00	2.75	24.0
	216.3	152079	–	76051	50686	6.4	270	381	70	10.9
10 250	10.750	54460	108920††	27230	18150	0.25	13.09	17.25	3.00	33.0
	273.0	242345	484500	121175	80770	6.4	332	438	76	15.0
267.4 mm	10.528	52230	–	26115	17410	0.25	13.09	17.25	3.00	33.0
	267.4	232424	–	116212	77475	6.4	332	438	76	15.0
12 300	12.750	76605	153210††	38300	25535	0.25	15.13	19.13	3.13	40.0
	323.9	340890	681520	170435	113630	6.4	384	486	80	18.1
318.5 mm	12.539	74100	–	37050	24700	0.25	15.13	19.13	3.13	40.0
	318.5	329745	–	164873	109915	6.4	384	486	80	18.1

* Refer to General Notes on pg. 1-4.

†† Cut grooved, sch. 40S duplex pipe

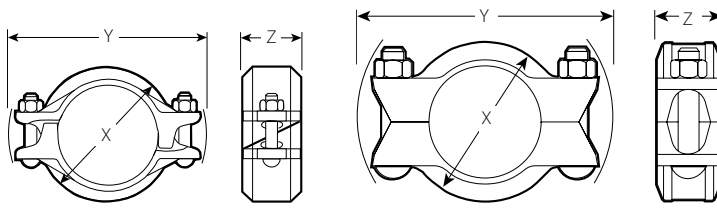

TYPICAL 1½–4"/40–100 mm SIZES

TYPICAL 6–12"/139.7–300 mm SIZES

Grooved System for Stainless Steel Pipe – Couplings

Rigid Coupling

STYLE 89

For Complete Information
Request Publication 17.24



- Heavy-duty, galvanized ductile iron housing designed for use specifically with stainless steel systems
- Wider housing key than standard coupling
- Provides an essentially rigid joint
- Pressure rated up to 1200 psi/8273 kPa for Schedule 40S duplex or Standard Wall, 750 psi/5175 kPa for Schedule 40S, 300 psi/2065 kPa for Schedule 10S, and 200 psi/1375 kPa for Schedule 5S; For specific pressure ratings by size and schedule, please refer to Publication 17.24
- Sizes from 2–12"/50–300 mm

Size		Max. End Load *				Allow. Pipe End Sep. *	Dimensions			Approx. Wgt.
Nominal Size Inches mm	Actual Outside Dia. Inches mm	Lbs. N					Inches mm	X Inches mm	Y Inches mm	
		Schedule 40S	Schedule 40S Duplex †	Schedule 10S	Schedule 5S	Lbs. kg				
2 50	2.375 60.3	3320 14774	5320 23676	1330 5919	890 3961	0.14 3.6	3.50 89	6.68 168	2.00 51	3.1 1.4
2½ 65	2.875 73.0	4875 21694	7800 34712	1950 8678	1300 5785	0.14 3.6	4.13 105	7.13 181	2.00 51	4.0 1.8
76.1 mm	3.000 76.1	5300 23585	8480 37736	2120 9434	1415 6297	0.14 3.6	4.13 105	7.25 184	2.00 51	4.1 1.9
3 80	3.500 88.9	7215 32107	11560 51444	2890 12861	1925 8566	0.14 3.6	4.75 121	7.75 197	2.00 51	4.3 2.0
4 100	4.500 114.3	11930 53089	19100 84996	4775 21249	3180 14151	0.25 6.4	6.00 152	9.63 245	2.13 54	7.5 3.4
139.7 mm	5.500 139.7	17820 79299	28520 126916	7130 31729	4750 21138	0.25 6.4	7.13 181	10.63 270	2.38 60	12.5 5.7
6 150	6.625 168.3	25850 115035	39820 177200	10340 46015	6895 30685	0.25 6.4	8.63 219	12.68 321	2.50 64	16.0 7.3
165.1 mm	6.500 165.1	24890 110761	41360 184060	9955 44300	6640 29548	0.25 6.4	8.63 219	12.68 321	2.38 60	15.8 7.2
8 200	8.625 219.1	35055 155995	68360 304204	17530 78010	11685 52000	0.25 6.4	11.00 279	15.00 381	2.75 70	26.1 11.8
216.3 mm	8.515 216.3	34175 152079	70100 311940	17090 76051	11390 50686	0.25 6.4	11.00 279	15.00 381	2.63 67	25.2 11.4
10 250	10.750 273.0	54460 242345	104460 464848	27230 121175	18150 80770	0.25 6.4	13.50 343	17.25 438	3.00 76	32.8 14.9
267.4 mm	10.528 267.4	52230 232424	108900 484600	26115 116212	17410 77475	0.25 6.4	13.38 340	17.00 432	2.75 70	32.5 14.7
12 300	12.750 323.9	76605 340890	148200 659492	38300 170435	25535 113630	0.25 6.4	15.63 397	19.63 499	2.88 73	46.0 20.9
318.5 mm	12.539 318.5	74100 329745	153200 681740	37050 164873	24700 109915	0.25 6.4	15.63 397	19.63 499	2.88 73	42.0 19.1
14 – 24 350 – 600		AGS™ See Style W89, pg. 5-4, Request Publication 20.15								

* Refer to General Notes on pg. 1-4.

† Cut grooved, Standard Wall or Schedule 40S stainless steel duplex pipe

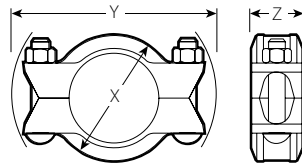

TYPICAL FOR ALL SIZES

Grooved System for Stainless Steel Pipe – Couplings

Flexible Coupling

STYLE 77S

For Complete Information
Request Publication 17.03



GROOVED SYSTEM FOR STAINLESS STEEL PIPE

- CE8MN duplex stainless steel or CF8M Type 316 stainless steel for corrosion resistance and strength
- Provides rugged, flexible mechanical joint for grooved stainless steel piping systems
- Pressure dependent on pipe size and wall thickness
- Pressure rated up to 1200psi/8273kPa on cut grooved Schedule 40S Duplex, 750psi/5175kPa for Schedule 40S, 500psi/3445kPa for Schedule 10S, and 325psi/2240kPa for Schedule 5S; For specific pressure ratings by size and schedule, please refer to Publication 17.03
- Sizes from 3/4–18"/20–450mm

Size		Max Perm. End Load				Allow. Pipe End Sep. *	Dimensions			Approx. Wgt. Each
Nominal Size Inches mm	Actual Outside Dia. Inches mm	Lbs. / N					Inches mm	X Inches mm	Y Inches mm	Z Inches mm
		Schedule 40S	Schedule 40††	Schedule 10S	Schedule 5S					
3/4	1.050	650	–	430	280	0 – 0.06	2.08	3.89	1.70	1.2
20	26.9	2893	–	1915	1245	0 – 1.6	53	99	43	0.6
1 ‡	1.315	1000	1600	680	440	0 – 0.06	2.54	4.50	1.66	1.8
25	33.7	4450	7120	3025	1960	0 – 1.6	65	114	42	0.8
1 1/4 ‡	1.660	1600	2500	1080	700	0 – 0.06	2.87	4.79	1.76	2.0
32	42.4	7120	11120	4805	3115	0 – 1.6	73	122	45	0.9
1 1/2 ‡	1.900	2100	3400	1415	920	0 – 0.06	3.24	4.80	1.76	2.2
40	48.3	9345	15120	6295	4095	0 – 1.6	82	122	45	1.0
2 ‡	2.375	3300	5300	2215	1440	0 – 0.06	3.70	5.33	1.84	2.6
50	60.3	14685	23757	9855	6408	0 – 1.6	94	135	47	1.2
2 1/2 ‡	2.875	4900	7700	3245	2110	0 – 0.06	4.20	5.79	1.84	3.0
65	73.0	21805	34250	14440	9390	0 – 1.6	107	147	47	1.4
3 ‡	3.500	7200	11500	3850	2405	0 – 0.06	4.83	6.99	1.84	4.1
80	88.9	32040	51150	17133	10702	0 – 1.6	123	178	47	1.9
4 ‡	4.500	6360	19000	5565	3580	0 – 0.13	5.93	9.00	2.06	6.8
100	114.3	28302	84500	24764	15931	0 – 3.2	151	229	52	3.1
6	6.625	10340	–	6900	4300	0 – 0.13	8.30	11.06	2.06	8.5
150	168.3	46013	–	30705	19135	0 – 3.2	211	281	52	3.9
8	8.625	17525	–	7300	4380	0 – 0.13	11.38	14.74	2.44	23.5
200	219.1	77896	–	32485	19491	0 – 3.2	229	374	62	10.7
10	10.750	27225	–	6810	4540	0 – 0.13	13.50	17.33	2.63	33.0
250	273.0	121151	–	30305	20203	0 – 3.2	343	440	67	15.0
12	12.750	38300	–	15960	9575	0 – 0.13	15.50	19.15	2.56	35.0
300	323.9	170435	–	71022	42609	0 – 3.2	394	486	65	15.9
14 †	14.000	30800	–	15400	10000	0 – 0.13	16.56	20.44	2.81	37.0
350	355.6	137060	–	68530	44500	0 – 3.2	421	519	71	16.8
16 †	16.000	25130	–	9050	7040	0 – 0.13	18.94	22.52	2.94	53.0
400	406.4	111829	–	40273	31328	0 – 3.2	481	572	75	24.0
18 †	18.000	25450	–	10180	7635	0 – 0.13	21.25	24.62	3.06	62.0
450	457.0	113253	–	45301	33976	0 – 3.2	540	625	78	25.0

* Refer to General Notes on pg. 1-4.

‡ Sizes 1-4"/25-100mm come standard in CE8MN duplex stainless steel. 3/4"/20mm, 6-18"/150-450mm come standard in CF8M Type 316 Stainless Steel.

† Not for use with AGS (Advance Groove System) products.

†† Cut grooved, sch. 40S duplex.

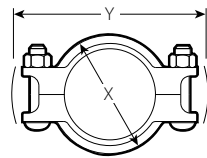

TYPICAL 3/4 – 14"/20 – 350mm SIZES

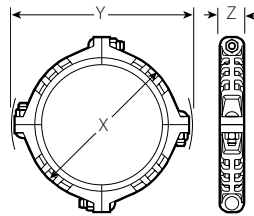
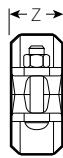

TYPICAL 16 – 18"/400 – 450mm SIZES

Grooved System for Stainless Steel Pipe – Couplings

Flexible Coupling

STYLE 475

For Complete Information
Request Publication 17.14



Size		Max. End Load *			Allow. Pipe End Sep. *	Dimensions			Approx. Wgt. Each
Nominal Size Inches mm	Actual Outside Dia. Inches mm	Lbs. N				Inches mm	X Inches mm	Y Inches mm	
		Schedule 40S	Schedule 10S	Schedule 5S					
1	1.315	1020	680	440	0 – 0.06	2.45	4.36	1.63	1.6
25	33.7	4539	3026	1958	0 – 1.6	62	111	41	0.7
1 1/4	1.660	1625	1080	700	0 – 0.06	2.84	4.67	1.72	2.4
32	42.4	7231	4806	3115	0 – 1.6	72	119	44	1.1
1 1/2	1.900	2125	1415	920	0 – 0.06	3.22	4.74	1.72	2.6
40	48.3	9456	6295	4094	0 – 1.6	82	120	44	1.2
2	2.375	2215	1550	1000	0 – 0.06	3.30	5.03	1.80	1.7
50	60.3	9857	6898	4450	0 – 1.6	84	128	46	0.8
2 1/2	2.875	3250	2275	1460	0 – 0.06	3.88	5.59	1.80	1.9
65	73.0	14463	10124	6497	0 – 1.6	99	142	46	0.9
76.1 mm	3.000	3535	2475	1590	0 – 0.06	4.00	5.73	1.80	2.0
	76.1	15731	11014	7076	0 – 1.6	102	146	46	0.9
3	3.500	4810	3370	2170	0 – 0.06	4.50	6.67	1.80	2.9
80	88.9	21405	14997	9657	0 – 1.6	114	169	46	1.3
4	4.500	5170	4775	3180	0 – 0.13	5.75	7.96	2.00	4.2
100	114.3	23007	21250	14150	0 – 3.2	146	202	51	1.9
139.7 mm	5.500	4750	4750	2970	0 – 0.13	6.81	8.97	2.00	4.9
	139.7	21138	21138	13217	0 – 3.2	173	228	51	2.2
165.1 mm †	6.500	6640	6640	4150	0 – 0.13	7.87	10.53	2.00	6.8
	165.1	29550	29550	18470	0 – 3.2	200	268	51	3.1

- CF8M stainless steel for corrosion resistance and strength
- Flexible system accommodates expansion/contraction/deflection
- Pressure rated up to 750 psi/5175 kPa for Schedule 40S, 500 psi/3447 kPa for Schedule 10S, and 325 psi/2240 kPa for Schedule 5S; For specific pressure ratings by size and schedule, please refer to Publication 17.14
- Sizes from 1–4"/25–165.1 mm

* Refer to General Notes on pg. 1-4.

† Denotes JIS pipe size.

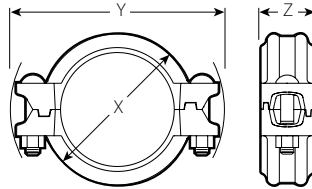

TYPICAL FOR ALL SIZES

Grooved System for Stainless Steel Pipe – Couplings

Vic-Flange Adapter ANSI Class 150

STYLE 441

For Complete Information
Request Publication 17.27



Size		Max. End Load *	Sealing Surface		Dimensions				Approx. Wgt. Each
Nominal Size Inches mm	Actual Outside Dia. Inches mm		A Min. Inches mm	B Max. Inches mm	W Inches mm	X Inches mm	Y Inches mm	Z Inches mm	Lbs. kg
2	2.375	1220	2.40	3.40	6.84	6.00	4.75	0.82	3.0
50	60.3	5429	61	86	174	152	121	21	1.4
2½	2.875	1785	2.90	3.90	7.72	7.00	5.50	0.88	4.3
65	73.0	7943	74	99	196	178	140	22	2.0
3	3.500	2645	3.50	4.50	8.22	7.50	6.00	0.94	4.8
80	88.9	11770	89	114	209	191	152	24	2.2
4	4.500	4375	4.50	5.50	9.72	9.00	7.50	0.94	6.9
100	114.3	19469	114	140	247	229	191	24	3.1
6	6.625	6895	6.60	7.80	11.78	11.00	9.50	1.00	9.5
150	168.3	30683	168	198	299	279	241	25	4.3

* Refer to Publication 17.27 for more details.

IMPORTANT NOTES:

For restrictions on where and how Vic-Flange adapters and flange washers can be used, refer to Publication 17.27.

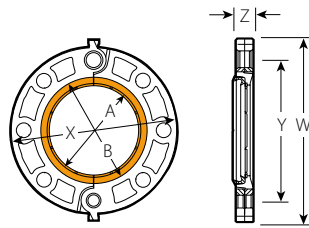

TYPICAL FOR ALL SIZES

Orange area of mating face must be free from gouges, undulations or deformities of any type for effective sealing.

- Designed to directly incorporate stainless flanged components with ANSI Class 150 bolt hole patterns into grooved stainless steel pipe system
- Pressure rated up to 275psi/1900kPa for Schedules 10S and 40S, and 200psi/1300kPa for Schedule 5S; For specific pressure ratings by size and schedule, please refer to Publication 17.27
- Sizes from 2–6½/50–150mm

Grooved System for Stainless Steel Pipe – Fittings

- NO. 410 SS** 90° Elbow
- NO. 411 SS** 45° Elbow
- NO. 420 SS** Tee
- NO. 460 SS** Cap

For Complete Information
Request Publication **17.16**

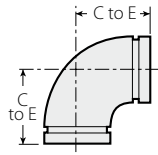

NO. 410 SS

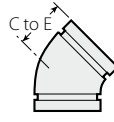

NO. 411 SS

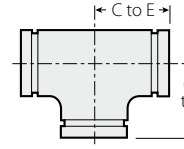

NO. 420 SS

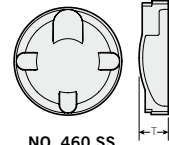

NO. 460 SS

Size	No. 410 SS 90° Elbow		No. 411 SS 45° Elbow		No. 420 SS Tee		No. 460 SS Cap	
	Nominal Size Inches mm	C to E Inches mm	Approx. Weight Each Lbs. kg	C to E Inches mm	Approx. Weight Each Lbs. kg	C to E Inches mm	Approx. Weight Each Lbs. kg	T Thickness Actual mm
3/4 26.9	—	—	—	—	—	—	0.79 20.0	0.12 0.05
1 33.7	2.88* 73.2	0.7 0.3	2.00* 50.8	0.6 0.3	—	—	0.79 20.0	0.18 0.08
1 1/4 42.4	3.13 79.5	1.0 0.5	2.00* 50.8	0.8 0.4	—	—	0.79 20.0	0.26 0.10
1 1/2 48.3	3.50* 88.9	1.3 0.6	2.19* 55.6	1.0 0.4	3.38* 113.6	2.2 1.0	0.79 20.0	0.38 0.20
2 60.3	4.50* 114.3	2.2 1.0	2.75* 69.9	1.6 0.7	2.75* 69.6	2.4 1.1	0.98 25.0	0.57 0.30
2 1/2 73.0	5.00* 127	3.3 1.5	2.81* 71.4	2.2 1.0	3.07* 78.0	3.7 1.7	1.08 27.0	0.90 0.40
3 88.9	4.50 114.3	2.6 1.2	2.00 50.8	1.3 0.6	3.77 95.7	3.1 0.4	1.03 26.0	1.10 0.50
4 114.3	6.00 152.4	4.7 2.1	2.50 63.5	2.3 2.5	4.47 113.6	4.9 2.2	1.22 31.1	1.80 0.80
6 168.3	9.00 228.6	11.0 5.0	3.75 95.3	5.5 2.5	5.91 150.00	11.7 5.3	1.75 44.0	4.00 1.80
8 219.1	12.00 304.8	21.2 9.6	5.00 127	11.0 5.0	7.79 197.8	20.4 9.3	2.23 57.0	7.00 3.20
10 273.0	15.00 381	36.6 16.6	6.25 158.8	18.5 8.4	8.89 225.9	34.4 15.6	2.72 69	17.8 8.10
12 323.9	18.00 457.2	59.6 25.8	7.50 190.5	28.4 12.9	10.39 264.0	52.4 23.8	3.17 83	26.7 12.10

IMPORTANT NOTES:

Schedule 10S, Type 304 or 316 stainless steel, roll grooved from material conforming to ASTM A-403.

*Schedule 10S, Grade CF8M (Type 316 stainless steel) conforming to ASTM A-351, A743 and A-744.

- Offered in a variety of standard fitting configurations
- Sizes to 12"/300mm

GROOVED SYSTEM FOR STAINLESS STEEL PIPE

Grooved System for Stainless Steel Pipe – Fittings

NO. 450 SS

For Complete Information
Request Publication **17.16**

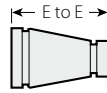

NO. 450 SS

Size		No. 450 SS Concentric Reducer	
Nominal Size Inches mm		E to E Inches mm	Approx. Weight Each Lbs. kg
2 50	× 1½ 40	5.00 127	2.5 1.1
2½ 65	× 2 50	5.00 127	1.1 0.49
3 80	× 2½ 65	5.00 127	1.5 0.7
4 100	× 3 80	5.00 127	2.0 0.9
6 150	× 3 80	5.50 139.7	6.9 3.1
	× 4 100	5.50 139.7	7.0 3.2
8 200	× 4 (sw) 100	6.00 152.4	4.2 1.9
	× 6 150	6.00 152.4	7.0 3.2
10 250	× 6 (sw) 150	7.00 177.8	18.0 8.2
	× 8 (sw) 200	7.00 177.8	19.6 8.9
12 300	× 8 (sw) 200	8.00 203.2	26.4 12.0
	× 10 (sw) 250	8.00 203.2	28.4 12.9

IMPORTANT NOTE:

Schedule 10S, Type 304 or 316 stainless steel, roll grooved from material conforming to ASTM A-403.

*Schedule 10S, Grade CF8M (Type 316 stainless steel) conforming to ASTM A-351, A743 and A-744.

(sw) Segmentally welded, not CR class fitting. Exception is 8"x4" concentric reducers which are CR class.

NO. 425 SS

For Complete Information
Request Publication **17.16**

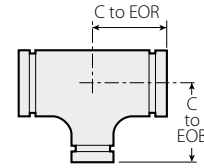

NO. 425 SS

Size			No. 425 SS Reducing Tee		
Nominal Size Inches mm			C to E Run Inches mm	C to E Branch Inches mm	Approx. Weight Each Lbs. kg
2 50	× 2 50	× 1½ 40	2.75 70.0	2.75 70.0	2.0 0.9
2½ 65	× 2½ 65	× 2 50	3.07 77.9	3.07 77.9	2.4 1.1
3 80	× 3 80	× 2½ 65	3.77 95.7	3.23 82.0	3.1 1.4
4 100	× 4 100	× 3 80	4.47 113.5	3.88 98.5	4.9 2.2
		× 4 100	5.91 150.0	5.12 130.0	9.5 4.3
8 200	× 8 200	× 4 100	7.79 197.8	6.31 160.2	18.1 8.2
		× 6 150	7.79 197.8	6.62 168.1	18.5 8.4
10 250	× 10 250	× 6 150	8.89 225.8	7.70 195.5	28.2 12.8
		× 8 200	8.89 225.8	8.59 218.1	31.3 14.2
12 300	× 12 300	× 8 200	10.39 263.9	9.51 241.5	40.1 18.2
		× 10 250	10.39 263.9	9.89 251.2	47.6 21.6

IMPORTANT NOTE:

No. 425 SS is manufactured from material conforming to ASTM A-403 Schedule 10S 304L or 316L.

Grooved System for Stainless Steel Pipe – Valves

Butterfly Valve

SERIES 763

For Complete Information
Request Publication **17.23**



**SERIES 763
WITH LEVER HANDLE**

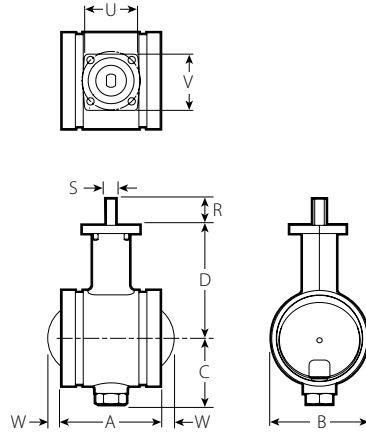

**SERIES 763 BUTTERFLY VALVE BARE
TYPICAL FOR ALL SIZES**

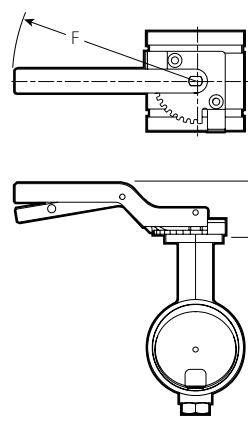

**SERIES 763 BUTTERFLY VALVE
WITH LEVER LOCK HANDLE
TYPICAL FOR ALL SIZES**

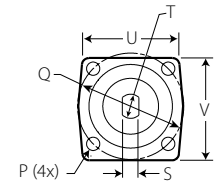

**ENLARGED MOUNTING FLANGE
TYPICAL 2 – 8"/50 – 200 mm SIZES
(VALVE SHOWN CLOSED)**

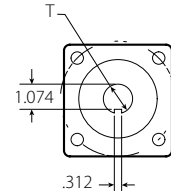

**ENLARGED MOUNTING FLANGE
TYPICAL 10"/250 mm SIZES
(VALVE SHOWN CLOSED)**

BARE VALVE AND WITH LEVER LOCK HANDLE

Size		Dimensions														Approx. Wgt. Each		Flow Coefficient@ (Fully Open) C _v Values K _v Values
Nominal Size Inches mm	Actual Out. Dia. Inches mm	A Inches mm	B Inches mm	C Inches mm	D Inches mm	E Inches mm	F Inches mm	P Inches mm	Q Inches mm	R Inches mm	S Inches mm	T Inches mm	U Inches mm	V Inches mm	W Inches mm	Bare Valve Lbs. kg	Lever Handle Lbs. kg	
2 50	2.375 60.3	3.20 81	2.37 60	2.09 53	4.17 106	2.38 60	8.51 216	0.34 9	2.76 70	1.25 32	0.31 8	0.43 11	2.48 63	2.65 67	—	3.5 1.6	4.7 2.1	110 95.2
2½ 65	2.875 73.0	3.77 96	3.00 76	2.47 63	4.38 111	2.38 60	8.51 216	0.34 9	2.76 70	1.25 31	0.31 8	0.43 11	2.48 63	2.65 67	—	4.5 2.0	5.7 2.6	200 173.0
76.1 mm	3.000 76.1	3.77 96	3.00 76	2.47 63	4.38 111	2.38 60	8.51 216	0.34 9	2.76 70	1.25 31	0.31 8	0.43 11	2.48 63	2.65 67	—	4.5 2.0	5.7 2.6	200 173.0
3 80	3.500 88.9	3.77 96	3.50 89	2.60 66	4.97 126	2.38 60	8.51 216	0.34 9	2.76 70	1.23 31	0.31 8	0.43 11	2.48 63	2.65 67	—	5.0 2.3	6.2 2.8	250 216.3
4 100	4.500 114.3	4.64 118	4.52 115	3.14 80	5.33 135	2.38 60	8.51 216	0.34 9	2.76 70	1.23 31	0.43 11	0.63 16	2.47 63	2.65 67	—	9.0 4.1	10.2 4.6	600 519.0
6 150	6.625 168.3	5.88 149	6.64 169	4.76 121	7.25 184	1.37 35	12.01 305	0.43 11	4.02 102	1.37 35	0.50 13	0.75 19	3.51 89	3.85 98	—	26.0 11.8	28.4 12.9	1400 1211.0
165.1 mm	6.500 165.1	5.88 149	6.64 169	4.76 121	7.25 184	1.37 35	12.01 305	0.43 11	4.02 102	1.37 35	0.50 13	0.75 19	3.51 89	3.85 98	—	26.0 11.8	28.4 12.9	1400 1211.0
8 200	8.625 219.1	5.32 135	9.75 248	5.73 145	8.57 218	1.37 35	12.01 305	0.43 11	4.02 102	1.37 35	0.75 19	1.00 25	3.40 86	3.85 98	1.24 32	41.0 18.6	43.4 19.7	3400 2941.0
10 250	10.750 273.0	6.40 163	12.10 307	7.05 179	10.09 256	—	—	0.53 13	4.92 125	2.13 54	—	1.25 32	4.62 117	4.77 121	1.72 44	65.0 29.5	—	5500 4757.5

- Stainless steel body with cast neck to accommodate insulation requirements
- ISO top flange will accept mounting of all major manual and power operators
- Seat options include EPDM, nitrile, fluoroelastomer, and lubricated nitrile (air and gas services only)
- Disc is stainless steel and provides bubble-tight shut-off at full rated pressure and temperature
- Pressure rates 300psi/2065kPa bi-directional and dead-end service
- Sizes from 2 – 10"/50–250 mm

@ C_v/K_v values for flow of water at +60°F/+16°C with valve fully open.



**SERIES 763
WITH POWER ACTUATOR**



**SERIES 763
WITH GEAR OPERATOR**

Grooved System for Stainless Steel Pipe – Valves

Butterfly Valve

SERIES 763

For Complete Information
Request Publication 17.23

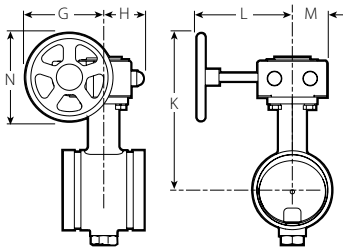

TYPICAL FOR ALL SIZES

ALUMINUM GEAR OPERATOR

Size		Dimensions						Approx. Wgt. Each
Nominal Size Inches mm	Actual Outside Dia. Inches mm	G Inches mm	H Inches mm	K Inches mm	L Inches mm	M Inches mm	N Inches mm	Lbs. kg
2 50	2.375 60.3	2.64 92	1.75 44	7.00 178	4.29 109	1.58 40	3.94 100	7.4 3.4
2½ 65	2.875 73.0	2.64 92	1.75 44	7.18 182	4.29 109	1.58 40	3.94 100	8.4 3.8
76.1 mm	3.000 76.1	2.64 92	1.75 44	7.18 182	4.29 109	1.58 40	3.94 100	8.4 3.8
3 80	3.500 88.9	2.64 92	1.75 44	7.77 197	4.29 109	1.58 40	3.94 100	8.9 4.0
4 100	4.500 114.3	4.43 112	2.28 58	8.93 227	4.65 118	1.97 50	4.92 125	12.9 5.9
6 150	6.625 168.3	6.30 160	3.25 82	12.62 320	7.75 197	2.87 73	7.87 200	33.2 15.1
165.1 mm	6.500 165.1	6.30 160	3.25 82	12.62 320	7.75 197	2.87 73	7.87 200	33.2 15.1
8 200	8.625 219.1	6.30 160	3.25 82	13.95 354	7.75 197	2.87 73	7.87 200	48.2 21.9
10 250	10.750 273.0	6.30 160	3.25 82	15.47 393	7.75 197	2.87 73	7.87 200	74.0 33.6

STAINLESS STEEL GEAR OPERATOR

Size		Dimensions						Approx. Wgt. Each
Nominal Size Inches mm	Actual Outside Dia. Inches mm	G Inches mm	H Inches mm	K Inches mm	L Inches mm	M Inches mm	N Inches mm	Lbs. kg
2 50	2.375 60.3	3.93 100	2.80 71	7.28 185	5.13 130	2.22 56	3.94 100	6.4 2.0
2½ 65	2.875 73.0	3.93 100	2.80 71	7.49 190	5.13 130	2.22 56	3.94 100	7.4 3.4
76.1 mm	3.000 76.1	3.93 100	2.80 71	7.49 190	5.13 130	2.22 56	3.94 100	7.4 3.4
3 80	3.500 88.9	3.93 100	2.80 71	8.08 205	5.13 130	2.22 56	3.94 100	7.9 3.6
4 100	4.500 114.3	4.92 125	2.80 71	9.42 239	5.32 135	2.22 56	5.90 150	11.9 5.4
6 150	6.625 168.3	6.59 167	3.54 90	12.92 328	9.00 229	2.97 75	8.46 215	32.2 14.6
165.1 mm	6.500 165.1	6.59 167	3.54 90	12.92 328	9.00 229	2.97 75	8.46 215	32.2 14.6
8 200	8.625 219.1	6.59 167	3.54 90	14.24 362	9.00 229	2.97 75	8.46 215	47.2 21.4
10 250	10.750 273.0	9.33 237	4.02 102	17.76 451	8.03 204	3.70 94	12.40 315	80.4 36.6

Grooved System for Stainless Steel Pipe – Valves

Swinger Check Valve

SERIES 712S

For Complete Information
Request Publication **17.08**



- Series 712S Swinger Check valves must not be installed in vertical pipe lines
- Supplied with bonnet cap drilled and tapped with ½"/15mm NPT pipe plug for chemical injection or other auxiliary connections
- Type 316 stainless steel body and trim in 2"/50mm size

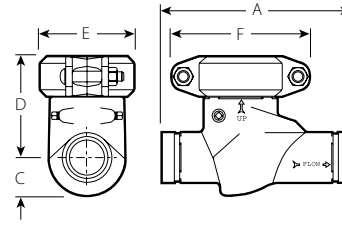

TYPICAL FOR 2"/50mm SIZE

Size		Dimensions					Approx. Weight Each without Operator	
Nominal Size Inches mm	Actual Outside Diameter Inches mm	A End to End Inches mm	C Inches mm	D Inches mm	E Inches mm	F Inches mm	Lbs. kg	
2 50	2.375 60.3	9.00 229	1.75 45	4.88 124	3.38 86	6.38 162	12.0 5.4	

Grooved System for Stainless Steel Pipe – Valves

Vic-Ball Valve

SERIES 726S

For Complete Information
Request Publication 17.22



Size		Dimensions											Approx. Wgt. Each	Flow Coefficient@ (Fully Open)
Nominal Size Inches mm	Actual Out. Dia. Inches mm	A Inches mm	B Inches mm	C Inches mm	D Inches mm	DA Inches mm	E Inches mm	F Inches mm	H Inches mm	J Inches mm	K Inches mm	L Inches mm	Lbs. kg	C _v Values K _v Values
1½ 40	1.900 48.3	5.12 130	2.00 51	2.36 60	1.25 32	1.50 38	1.78 45	1.90 48	3.00 76	0.28 7	0.56 14	6.97 177	4.7 2.1	130 112.5
2 50	2.375 60.3	5.50 140	2.64 67	2.48 63	1.50 38	2.00 51	2.25 57	2.38 60	3.31 84	0.34 9	0.56 14	6.97 177	7.5 3.4	180 155.7
2½ 65	2.875 73.0	6.25 159	3.03 77	2.80 71	1.97 50	2.50 64	2.72 69	2.88 73	4.00 102	0.34 9	0.56 14	9.84 250	11.5 5.2	340 294.1
3 80	3.500 88.9	6.56 167	3.50 89	3.15 80	2.50 64	3.00 76	3.34 85	3.50 89	4.53 115	0.34 9	0.56 14	9.84 250	17.3 7.8	600 519.0
4 100	4.500 114.3	8.25 210	—	3.35 85	2.99 76	4.00 102	4.33 111	4.52 115	5.48 139	0.34 9	0.61 15	15.67 398	44.0 20.5	650 562.3
6 150	6.625 168.3	10.10 257	—	4.53 115	4.00 102	6.00 152	6.46 164	6.64 169	6.48 165	0.34 9	0.61 15	18.07 459	82.0 37.3	800 692.0

@ C_v/K_v values for flow of water at +60°F/+16°C with valve fully open.

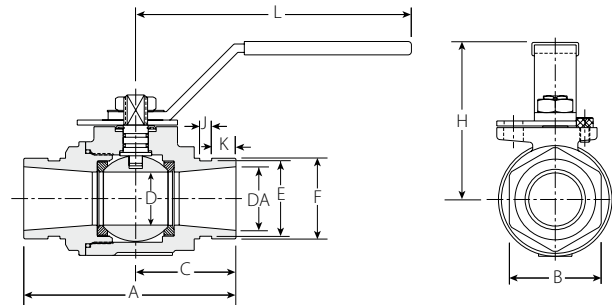

TYPICAL 1½–3"/40–80 mm SIZES

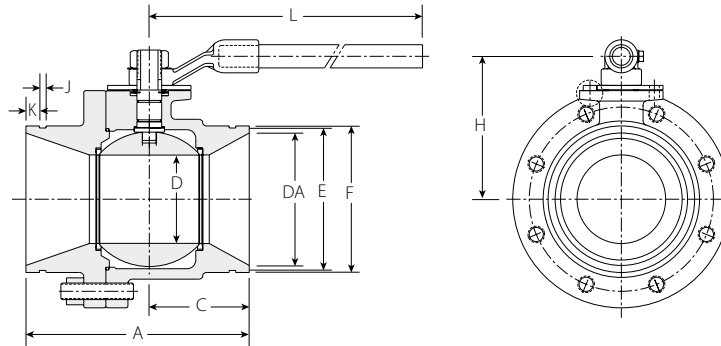

TYPICAL 4"/100 mm AND 6"/150 mm SIZES

GROOVED SYSTEM FOR STAINLESS STEEL PIPE

- High-pressure standard port ball valve with grooved ends
- Two-piece, end-entry features floating ball for lower torque requirements
- NACE compliant
- Streamline internal design provides excellent flow characteristics
- Valve features stainless steel ball and stem
- Pressure rated up to 1000psi/6900kPa for sizes 1½–3"/40–80mm
- Pressure rated up to 800psi/5515kPa for sizes 4–6"/100–150mm
- Sizes from 1½–6"/40–150mm

Pressfit System for Stainless Steel Pipe

The Pressfit system is a small diameter, quick-connect piping system solution that delivers speed, economy and reliability to building owners, contractors, and specifying engineers.

Pressfit delivers real on-the-job pipe joining advantages to fitters and installers – benefits that you won't find in standard threaded, welded or flanged systems.

The Pressfit system is ideal for a wide variety of process and utility applications requiring the corrosion-resistant properties of stainless steel. Pressfit integrates well with larger stainless steel piping systems, especially those designed with our grooved end products.



Product Line



Standard Coupling, pg. 9-4



Slip Coupling, pg. 9-4

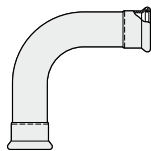

90° Elbow, pg. 9-5

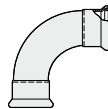

Short Tangent 90° Elbow, pg. 9-5

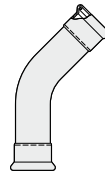

45° Elbow, pg. 9-5

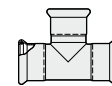

Tee, pg. 9-6

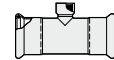

Tee with Thd. Branch, pg. 9-6

PRESSFIT	304	STYLE 597		STYLE 590	STYLE 586	STYLE 591	STYLE 592	STYLE 588
	316	STYLE 507	STYLE 508	STYLE 570	STYLE 568	STYLE 571	STYLE 572	STYLE 578

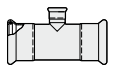

Tee with Reducing Branch, pg. 9-7



Male Adapter, pg. 9-7



Female Thd. Adapter, pg. 9-8



Weld Adapter, pg. 9-8

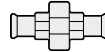

Threaded Union, pg. 9-8

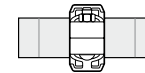

Grooved End Union, pg. 9-9



Flange Adapter, pg. 9-9

PRESSFIT	304	STYLE 593	STYLE 596	STYLE 599	STYLE 561	STYLE 584	STYLE 547	STYLE 595
	316	STYLE 573	STYLE 576	STYLE 579		STYLE 585	STYLE 548	STYLE 575



Van Stone Flange Adapter, pg. 9-9



Transition Nipple, pg. 9-10



Reducer Insert, pg. 9-10



Concentric Reducer, pg. 9-10

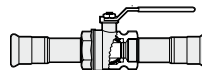

Ball Valve, pgs. 9-11, 12

PRESSFIT	304	STYLE 565	STYLE 587	STYLE 582	STYLE 594	STYLE 589
	316	STYLE 566	STYLE 577	STYLE 583	STYLE 574	STYLE 569

Pressfit System for Stainless Steel Pipe

How It Works

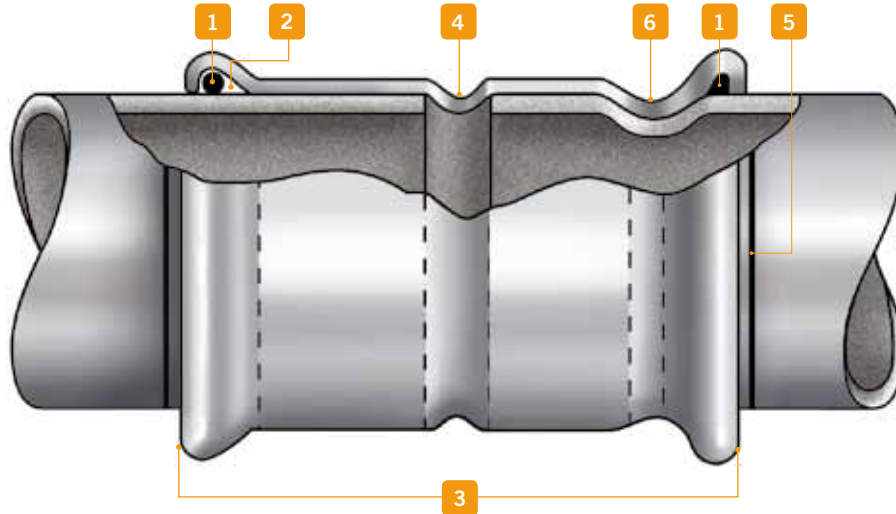

1 O-RING

Precisely molded gasket made of synthetic rubber in several application grades for a variety of wet and dry services.

2 O-RING POCKET

Sized to contain the ring before assembly, the pocket is deformed around the o-ring during compression to fully surround the pipe for a leak-free seal.

3 HOUSING

Precision formed stainless steel construction incorporating the pipe stop and o-ring. Adapters are available for easy field make-up of fitting combinations to threaded components.

4 PIPE STOP

An internal pipe stop locates pipe position to ensure positive joining.

5 INSERTION MARK

A witness mark on the pipe ensures visual verification that the pipe has been fully inserted for proper installation.

6 TOOL INDENT

The Pressfit hand tool engages the entire circumference of the bead on the fitting housing to ensure a secure attachment of pipe to fitting.



Pressfit Tools



PFT 509



PFT 505

The Pressfit System requires a Pressfit tool designed for securing Pressfit products onto pipe. The Pressfit tool packages include the actual pressing tool and any customer-specified press jaws. Jaws are available separately for rental or purchase. The PFT505 and PFT509 Pressfit tools are designed for industrial and trade use only. See pg. 17-11 for more details.

Pressfit System for Stainless Steel Pipe

Stainless Steel Pipe System – Performance

- Available for Type 304 or Type 316 stainless steel systems
- Full range of couplings, fittings and valves
- Handheld tools used to join pipe in seconds
- Up to four times faster than stainless steel socket weld systems
- UL classified in accordance with ANSI/NSF 61 for cold +86°F/+30°C and hot +180°F/+82°C potable water service
- Meets hanging requirements of ASME B31.1, B31.3 and B31.9
- Request Publication 18.01 for Type 316 or 18.02 for Type 304
- Pressure rated up to 300 psi/2065 kPa in all sizes
- Sizes from ½–2"/15–50 mm Schedule 5 stainless steel piping is fast, easy, clean and reliable method for joining

PRODUCTS

- 1-1 Couplings
- 2-1 Fittings
- 3-1 Valves
- 4-1 Accessories
- 5-1 Advanced Groove System
- 6-1 Hole Cut Piping System
- 7-1 Plain End Piping System
- 8-1 Grooved System for Stainless Steel Pipe

9-1 Pressfit System for Stainless Steel Pipe

- 10-1 Plain End Piping System for HDPE Pipe
- 11-1 Grooved Copper
- 12-1 PermaLynx System for Copper Tube
- 13-1 Grooved AWWA Ductile Iron Pipe
- 14-1 Victaulic Depend-O-Lok® System
- 15-1 Aquamine Reusable PVC Products
- 16-1 Gaskets
- 17-1 Pipe Preparation Tools
- 18-1 Product Index
- 19-1 Piping Software

Vic-Press 304

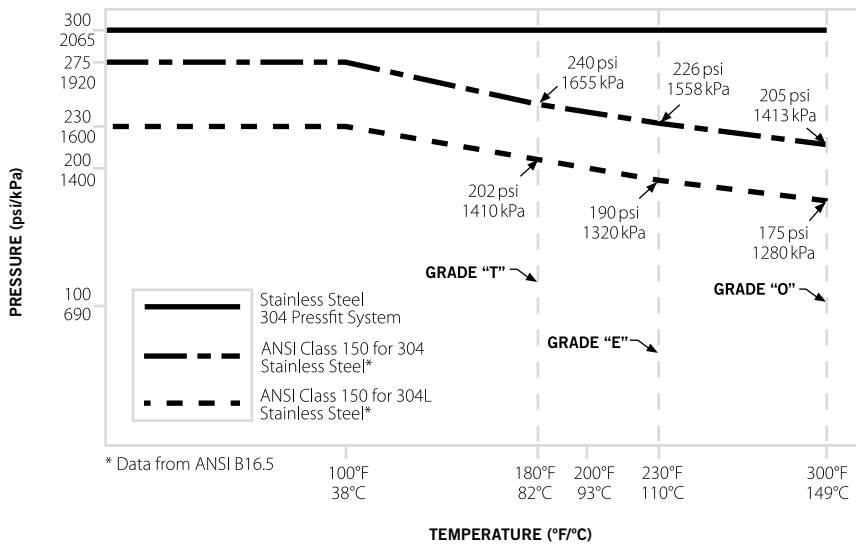

Vic-Press 316

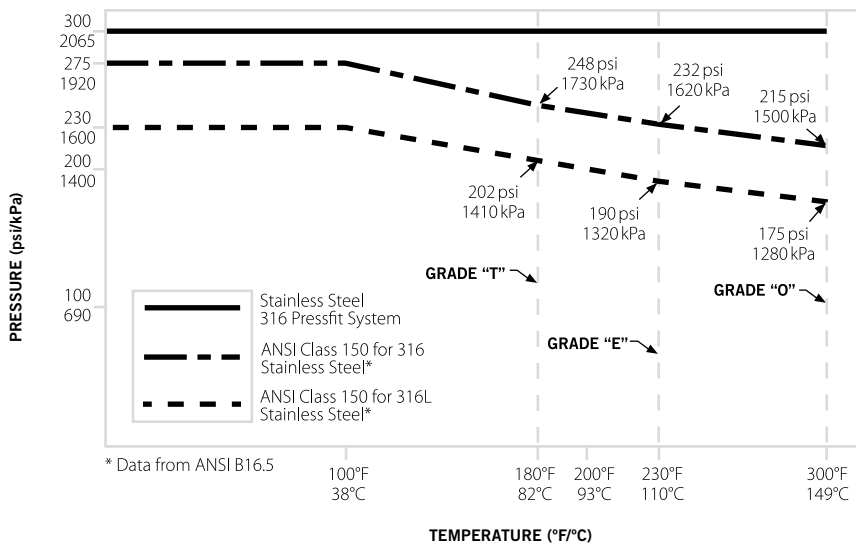

Pressfit System for Stainless Steel Pipe

Dimensional Information

Products in the Vic-Press 304/316 System have unique center-to-end or end-to-end dimensions which incorporate specific, uniform “takeout” dimensions for easy fabrication calculations.

Use of threaded products employing special features such as probes, escutcheon cups, etc., should be checked to be certain the thread standard and length of insertion are compatible with fitting dimensions. Failure to verify dimensional suitability in advance may result in difficulties in assembly.

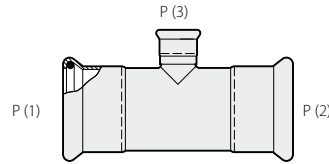

END TYPE CODE

- P = Pressfit
- F = Female Pipe Thread
- M = Male Pipe Thread
- T = Plain End
- L = Flanged
- G = Grooved

Standard Coupling

STYLE 597 (P × P)
STYLE 507 (P × P)

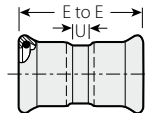

STYLE 597 & 507

Size		Dimensions		Approx. Weight Each
Nominal Size Inches mm	Actual Outside Diameter Inches mm	E to E Inches mm	U Takeout Inches mm	Lbs. kg
1/2 15	0.840 21.3	2.00 51	0.35 9	0.1 0.1
3/4 20	1.050 26.7	2.17 55	0.28 7	0.2 0.1
1 25	1.315 33.7	2.44 62	0.39 10	0.2 0.1
1 1/2 40	1.900 48.3	3.15 80	0.32 8	0.5 0.2
2 50	2.375 60.3	3.94 100	0.33 8	0.7 0.3

STANDARD COUPLING

PRESSFIT	304	STYLE 597	Request Publication 18.02
	316	STYLE 507	Request Publication 18.01

Slip Coupling

STYLE 508 (P × P)

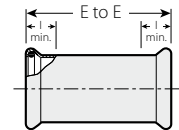

STYLE 508

Size		Dimensions		Approx. Weight Each
Nominal Size Inches mm	Actual Outside Diameter Inches mm	E to E Inches mm	I Min. Tube Insert Inches mm	Lbs. kg
1/2 15	0.840 21.3	3.31 84	1.00 25	0.1 0.1
3/4 20	1.050 26.7	3.54 90	1.00 25	0.2 0.1
1 25	1.315 33.7	3.94 100	1.00 25	0.3 0.1
1 1/2 40	1.900 48.3	4.72 120	1.00 25	0.6 0.3
2 50	2.375 60.3	5.51 140	1.25 32	0.9 0.4

SLIP COUPLING

PRESSFIT	316	STYLE 508	Request Publication 18.01
----------	------------	------------------	---------------------------

Pressfit System for Stainless Steel Pipe

Elbows

- STYLE 590** 90° Elbow (P × P)
- STYLE 570** 90° Elbow (P × P)
- STYLE 586** Short Tangent 90° Elbow (P × P)
- STYLE 568** Short Tangent 90° Elbow (P × P)
- STYLE 591** 45° Elbow (P × P)
- STYLE 571** 45° Elbow (P × P)

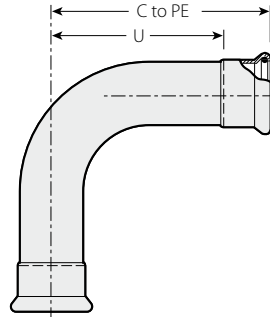

STYLE 590 & 570

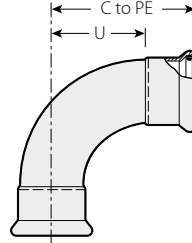

STYLE 586 & 568

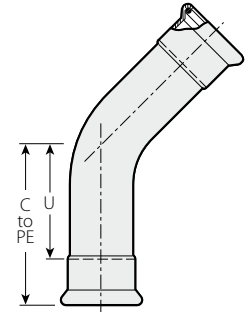

STYLE 591 & 571

Size		Style 590 & 570 90° Elbow			Style 586 & 568 Short Tangent 90° Elbow			Style 591 & 571 45° Elbow		
Nominal Size Inches mm	Actual Outside Diameter Inches mm	C to PE Inches mm	U Takeout Inches mm	Approx. Weight Each Lbs. kg	C to PE Inches mm	U Takeout Inches mm	Approx. Weight Each Lbs. kg	C to PE Inches mm	U Takeout Inches mm	Approx. Weight Each Lbs. kg
1/2	0.840	2.67	1.88	0.3	—	—	—	1.65	0.82	0.2
15	21.3	68	48	0.1	—	—	—	42	21	0.1
3/4	1.050	3.43	2.48	0.4	2.83	1.88	0.3	2.44	1.50	0.3
20	26.7	87	63	0.2	72	48	0.2	62	38	0.1
1	1.315	4.33	3.31	0.6	3.36	2.34	0.5	3.11	2.09	0.5
25	33.7	110	84	0.3	85	59	0.2	79	53	0.2
1 1/2	1.900	6.73	5.32	1.4	4.60	3.19	1.0	5.00	3.59	1.3
40	48.3	171	135	0.6	117	81	0.5	127	91	0.6
2	2.375	8.19	6.38	2.3	5.71	3.90	1.5	6.02	4.22	2.0
50	60.3	208	162	1.0	145	99	0.7	153	107	0.9

90° ELBOW

PRESSFIT	304	STYLE 590	Request Publication 18.02
	316	STYLE 570	Request Publication 18.01

SHORT TANGENT 90° ELBOW

PRESSFIT	304	STYLE 586	Request Publication 18.02
	316	STYLE 568	Request Publication 18.01

45° ELBOW

PRESSFIT	304	STYLE 591	Request Publication 18.02
	316	STYLE 571	Request Publication 18.01

Pressfit System for Stainless Steel Pipe

Tee

STYLE 592 (P × P × P)
STYLE 572 (P × P × P)

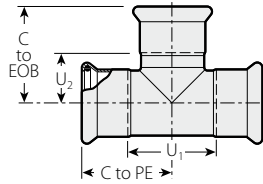

STYLE 592 & 572

Tee with Threaded Branch

STYLE 588 (P × P × F)
STYLE 578 (P × P × F)

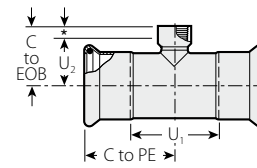

STYLE 588 & 578

* Length of effective thread.

Size		Dimensions				Approx. Wgt. Each
Nominal Size Inches mm	Actual Outside Dia. Inches mm	C to PE Inches mm	U ₁ Inches mm	C to EOB Inches mm	U ₂ Inches mm	Lbs. kg
1/2 15	0.840 21.3	1.40 36	1.04 26	1.60 41	0.72 18	0.2 0.1
3/4 20	1.050 26.7	1.89 48	1.89 48	1.89 48	0.95 24	0.3 0.1
1 25	1.315 33.7	2.11 54	2.17 55	2.15 55	1.13 29	0.4 0.2
1 1/2 40	1.900 48.3	2.76 70	2.69 68	2.80 71	1.39 35	0.9 0.4
2 50	2.375 60.3	3.39 86	3.17 81	3.62 92	1.81 46	1.4 0.6

TEE

PRESSFIT	304	STYLE 592	Request Publication 18.02
	316	STYLE 572	Request Publication 18.01

Size		Dimensions				Approx. Wgt. Each
Nominal Size Inches mm		C to PE Inches mm	U ₁ Inches mm	C to EOB Inches mm	U ₂ Inches mm	Lbs. kg
1/2 15	1/2 15	1.50 38	1.35 34	1.50 38	0.97 25	0.2 0.1
3/4 20	3/4 20	1.89 48	1/2 15	1.64 42	1.11 28	0.3 0.2
			3/4 20	1.71 43	1.16 29	0.4 0.2
1 25	1 25	2.11 54	1/2 15	1.78 45	1.25 32	0.4 0.2
			3/4 20	1.85 47	1.30 33	0.5 0.2
			1 25	2.02 51	1.34 34	0.6 0.3
1 1/2 40	1 1/2 40	2.76 70	1/2 15	2.07 53	1.54 39	0.8 0.4
			3/4 20	2.14 54	1.59 40	0.9 0.4
			1 25	2.31 59	1.63 40	0.9 0.4
2 50	2 50	3.39 86	1/2 15	2.31 59	1.78 45	1.2 0.5
			3/4 20	2.38 60	1.83 46	1.3 0.6
			1 25	2.55 65	1.87 48	1.3 0.6

TEE WITH THREADED BRANCH

PRESSFIT	304	STYLE 588	Request Publication 18.02
	316	STYLE 578	Request Publication 18.01

Pressfit System for Stainless Steel Pipe

Tee with Reducing Branch

STYLE 593 (P × P × P)
STYLE 573 (P × P × P)

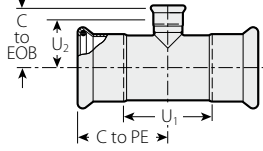

STYLE 593 & 573

Male Threaded Adapter

STYLE 596 (P × M)
STYLE 576 (P × M)

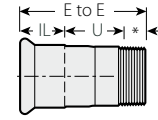

STYLE 596 & 576

* Length of effective thread.

Size			Dimensions				Approx. Weight Each				
Nominal Size Inches mm			C to PE Inches mm	U ₁ Inches mm	C to EOB Inches mm	U ₂ Inches mm	Lbs. kg				
3/4 20	×	3/4 20	1.90 48	1.91 48	2.10 53	1.27 32	0.3 0.1				
		1/2 15					0.3 0.1				
1 25	×	1 25	2.10 53	2.15 55	2.30 58	1.47 37	0.3 0.1				
							3/4 20	0.4 0.2			
		1 1/2 40					2.76 70	2.69 68	2.60 66	1.77 45	0.6 0.3
							3/4 20	2.76 70	2.69 68	2.32 59	1.68 43
2 50	×	2 50	3.39 86	3.17 81	2.80 71	1.97 50	1.2 0.5				
							3/4 20	1.3 0.6			
		1 25					3.39 86	3.17 81	2.68 68	1.66 42	1.1 0.5
							1 1/2 40	3.39 86	3.17 81	3.03 77	1.62 41

TEE WITH REDUCING BRANCH †

PRESSFIT	304	STYLE 593	Request Publication 18.02
	316	STYLE 573	Request Publication 18.01

Size		Dimensions			Approx. Weight Each		
Nominal Size Inches mm		E to E Inches mm	U Takeout Inches mm	IL Insert. Length Inches mm	Lbs. kg		
1/2 15	×	1/2 15	3.68 93	2.32 59	0.83 21	0.2 0.1	
			3/4 20	1.75 44	0.95 24	0.3 0.1	
3/4 20	3.72 94	2.22 56		0.95 24	0.3 0.1		
1 25	3.22 82	1.60 41		0.95 24	0.4 0.2		
1 25	×	3/4 20		3.34 85	1.77 45	1.02 26	0.4 0.1
			1 25	4.02 102	2.32 59	1.02 26	0.4 0.2
1 1/2 40	×	3/4 20	3.69 94	1.73 44	1.42 36	0.6 0.3	
			1 1/2 40	4.40 112	2.27 58	1.42 36	0.7 0.3
				2 50	5.03 128	2.46 62	1.81 46

MALE THREADED ADAPTER

PRESSFIT	304	STYLE 596	Request Publication 18.02
	316	STYLE 576	Request Publication 18.01

† Available with female threaded outlet. Contact Victaulic.

Pressfit System for Stainless Steel Pipe

Female Threaded Adapter

STYLE 599 (P x F)
STYLE 579 (P x F)

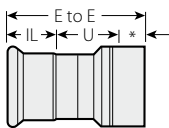

STYLE 599 & 579

* Length of effective thread.

Size	Dimensions			Approx. Weight Each	
	Nominal Size Inches mm	E to E Inches mm	U Takeout Inches mm		IL Insert Length Inches mm
1/2 x 1/2 15 x 15	2.15 55	0.79 20	0.83 21	0.2 0.1	
	3/4 x 1/2 20 x 15	2.20 56	0.71 18	0.95 24	0.2 0.1
3/4 x 3/4 20 x 20		2.20 56	0.79 20	0.95 24	0.2 0.1
	1 x 1/2 25 x 15	2.30 58	0.75 19	1.02 26	0.4 0.2
3/4 x 3/4 20 x 20		2.30 58	0.73 19	1.02 26	0.3 0.1
		1 x 1 25 x 25	2.40 61	0.75 19	1.02 26
1 1/2 x 1 40 x 25	2.96 75	0.92 23	1.42 36	0.8 0.4	
	1 1/4 x 1/2 32 x 15	2.96 75	0.87 22	1.42 36	0.6 0.3
		1 1/2 x 1/2 40 x 15	2.96 75	0.87 22	1.42 36
2 x 1 1/4 50 x 32	3.75 95	1.27 32	1.81 46	0.9 0.4	
	1 1/2 x 1/2 40 x 15	3.75 95	1.27 32	1.81 46	1.1 0.5
		2 x 1/2 50 x 15	3.75 95	1.27 32	1.81 46

FEMALE THREADED ADAPTER

PRESSFIT	304	STYLE 599	Request Publication 18.02
	316	STYLE 579	Request Publication 18.01

Weld Adapter

STYLE 561 (P x T)

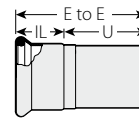

STYLE 561

Size	Dimensions			Approx. Weight Each
	Nominal Size Inches mm	E to E Inches mm	U Takeout Inches mm	
1/2 x 1/2 15 x 15	3.68 93	2.85 72	0.83 21	0.2 0.1
	3/4 x 3/4 20 x 20	3.72 94	2.77 70	0.95 24
1 x 1 25 x 25	4.02 102	3.00 76	1.02 26	0.4 0.2
	1 1/2 x 1 1/2 40 x 40	4.40 112	2.98 76	1.42 36
2 x 2 50 x 50	5.03 128	3.22 82	1.81 46	1.0 0.5

WELD ADAPTER

PRESSFIT	304	STYLE 561	Request Publication 18.02
----------	------------	------------------	---------------------------

Threaded Union

STYLE 584 (P x P)
STYLE 585 (P x P)

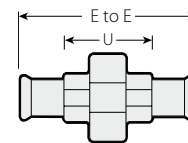

STYLE 584 & 585

Size	Dimensions		Approx. Weight Each	
	Nominal Size Inches mm	Actual Outside Diameter Inches mm		E to E Inches mm
1/2 15	0.840 21.3	7.02 178	5.27 134	2.80 1.3
	3/4 20	1.050 26.7	7.14 181	5.14 131
1 25		1.315 33.7	7.26 184	5.26 134
	1 1/2 40	1.900 48.3	8.44 214	5.44 138
2 50		2.375 60.3	8.38 213	4.67 119

THREADED UNION

PRESSFIT	304	STYLE 584	Request Publication 18.02
	316	STYLE 585	Request Publication 18.01

Pressfit System for Stainless Steel Pipe

Grooved End Union

STYLE 547
STYLE 548

Request Publication 06.02 for Style 77 Flexible Joint
Request Publication 06.04 for Style 07 Rigid Joint
Request Publication 17.03/17.14 for Style 77S/475 Flexible Joints
Request Publication 17.25 for Style 489 Rigid Joints

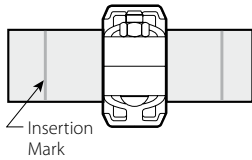

PRESSFIT	304	STYLE 547	Request Publication 18.02
	316	STYLE 548	Request Publication 18.01

- Style 547/548 grooved end union can be formed with two Style 577 transition nipples and a variety of grooved end couplings with varied gaskets to meet service requirements
- Standard ductile iron couplings request Style 77 for flexible joints or Style 07 for rigid joints
- Where external corrosion is a concern request Style 77S/475 for flexible joints or Style 489 for rigid joints

Flange Adapter

STYLE 595 (P × L)
STYLE 575 (P × L)

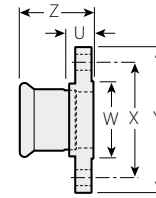

STYLE 595 & 575

Size		Dimensions					Approx. Weight Each
Nominal Size Inches mm	Actual Out. Dia. Inches mm	U Takeout Inches mm	W Inches mm	X Inches mm	Y Inches mm	Z Inches mm	Lbs. kg
1/2 15	0.840 21.3	2.34 59	1.38 35	2.38 60	3.50 89	3.22 82	2.3 1.1
3/4 20	1.050 26.7	2.27 58	1.69 43	2.75 70	3.88 99	3.22 82	1.7 0.8
1 25	1.315 33.7	2.27 58	2.00 51	3.12 79	4.25 108	3.29 84	2.2 1.0
1 1/2 40	1.900 48.3	2.07 53	2.88 73	3.88 99	5.00 127	3.48 88	3.6 1.6
2 50	2.375 60.3	1.80 46	3.62 92	4.75 121	6.00 152	3.60 92	5.4 2.4

FLANGE ADAPTER

PRESSFIT	304	STYLE 595	Request Publication 18.02
	316	STYLE 575	Request Publication 18.01

Van Stone Flange Adapter

STYLE 565 (P × L)
STYLE 566 (P × L)

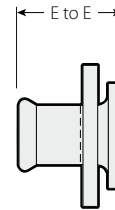

STYLE 565 & 566

Size		Dimensions	Approx. Weight Each
Nominal Size Inches mm	Actual Outside Diameter Inches mm	E to E Inches mm	Lbs. kg
1/2 15	0.840 21.3	3.12 79	3.00 1.4
3/4 20	1.050 26.7	3.17 81	3.30 1.5
1 25	1.315 33.7	3.28 83	3.60 1.6
1 1/2 40	1.900 48.3	3.64 93	5.00 2.3
2 50	2.375 60.3	4.73 120	5.90 2.7

VAN STONE FLANGE ADAPTER †

PRESSFIT	304	STYLE 565	Request Publication 18.02
	316	STYLE 566	Request Publication 18.01

† Available with carbon steel (standard) or 316 stainless steel (optional) back-up flange. Specify choice on order.

Pressfit System for Stainless Steel Pipe

Transition Nipple

STYLE 587 (G × T)
STYLE 577 (G × T)

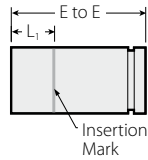

STYLE 587 & 577

Size		Dimensions		Approx. Weight Each
Nominal Size Inches mm	Actual Outside Diameter Inches mm	E to E Inches mm	L ₁ Minimum Inches mm	Lbs. kg
3/4 20	1.050	4.00	1.00	0.2
	26.7	102	25	0.1
1 25	1.315	4.00	1.00	0.3
	33.7	102	25	0.1
1 1/2 40	1.900	4.00	1.50	0.4
	48.3	102	38	0.2
2 50	2.375	4.00	1.88	0.5
	60.3	102	48	0.2

TRANSITION NIPPLE

PRESSFIT	304	STYLE 587	Request Publication 18.02
	316	STYLE 577	Request Publication 18.01

Concentric Reducer

STYLE 594 (T × T)
STYLE 574 (T × T)

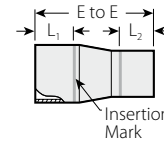

STYLE 594 & 574

Size		Dimensions			Approx. Weight Each
Nominal Size Inches mm		E to E Inches mm	L ₁ Minimum Inches mm	L ₂ Minimum Inches mm	Lbs. kg
3/4 20	× 1/2 15	3.50	1.00	0.88	0.2
		89	25	22	0.1
1 25	× 1/2 15	3.56	1.03	0.88	0.2
		90	26	22	0.1
	3/4 20	3.56	1.03	1.00	0.2
1 1/2 40	× 1/2 15	4.25	1.44	0.88	0.3
		108	37	22	0.1
	3/4 20	4.25	1.44	1.00	0.4
1 25	× 1/2 15	4.25	1.44	1.03	0.4
		108	37	26	0.2
	3/4 20	5.00	1.81	1.03	0.6
2 50	× 1/2 15	5.00	1.81	0.88	0.6
		127	46	22	0.3
	3/4 20	5.00	1.81	1.00	0.6
1 25	× 1/2 15	5.00	1.81	1.03	0.6
		127	46	26	0.3
	3/4 20	5.00	1.81	1.44	0.7
1 1/2 40	× 1/2 15	5.00	1.81	1.44	0.7
		127	46	37	0.3

CONCENTRIC REDUCER

PRESSFIT	304	STYLE 594	Request Publication 18.02
	316	STYLE 574	Request Publication 18.01

Reducer Insert

STYLE 582 (T × P)
STYLE 583 (T × P)

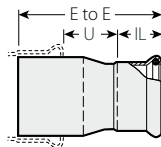

STYLE 582 & 583

Size		Dimensions			Approx. Weight Each
Nominal Size Inches mm		E to E Inches mm	U Takeout Inches mm	IL Insertion Length Inches mm	Lbs. kg
1 25	× 3/4 20	2.95	0.98	0.95	0.2
		75	25	24	0.1
2 50	× 1 1/2 40	4.33	1.11	1.42	0.6
		110	28	36	0.3

REDUCER INSERT

PRESSFIT	304	STYLE 582	Request Publication 18.02
	316	STYLE 583	Request Publication 18.01

Pressfit System for Stainless Steel Pipe

Vic-Press 304™ Brass Body Ball Valve with Stainless Steel Pressfit Ends

SERIES 589 (P × P)

Request Publication 18.02



Size		Dimensions				Approx. Weight Each	Flow Coefficient@ (Fully Open)
Nominal Size Inches mm	Actual Outside Diameter Inches mm	A End to End Inches mm	C Inches mm	F Inches mm	U Takeout Inches mm	Lbs. kg	C _v Values K _v Values
1/2	0.840	8.49	1.33	3.07	6.84	0.9	10
15	21.3	216	34	78	174	0.4	8.7
3/4	1.050	8.88	1.79	3.78	6.99	1.3	25
20	26.7	226	46	96	178	0.6	21.6
1	1.315	9.74	1.95	3.78	7.69	1.8	37
25	33.7	247	50	96	195	0.8	32.0
1 1/2	1.900	11.09	2.68	5.43	8.26	3.4	87
40	48.3	282	68	138	210	1.5	75.3
2	2.375	12.90	2.89	5.43	9.29	4.4	110
50	60.3	328	73	138	236	2.0	95.2

@ C_v/K_v values for flow of water at +60°F/+16°C with valve fully open.

- Valve body constructed of forged brass
- Chrome plated brass ball and seals on TFE seats
- Standard port valve with Pressfit ends
- Pressure rated up to 300 psi/2065 kPa
- Sizes from 1/2–2”/15–50 mm

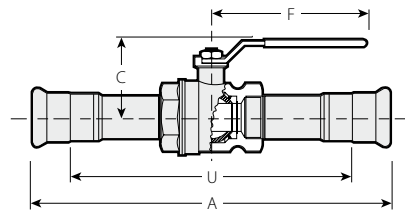

TYPICAL FOR ALL SIZES

Pressfit System for Stainless Steel Pipe

Vic-Press 316™ Type 316 Stainless Steel Ball Valve

SERIES 569

Request Publication 18.01



- Body and trim constructed of rugged Type 316 (CF8M) stainless steel with PTFE seats
- Blow-out proof stem self-adjusting floating ball
- Full-port design minimizes pressure drop for flow efficiency
- Three-piece swing-out design permits easy in-line maintenance
- Pressure rated up to 300 psi/2065 kPa with plain ends
- Pressure rated up to 400 psi/2750 kPa with grooved ends
- Sizes from ½–2"/15–50mm
- Repair Kits and replacement parts are available for the Series 569 valve
- The Repair Kit consists of two seats, two gaskets, one stem seal, and one thrust washer, all made of PTFE. A replacement ball of CF8M stainless steel is also available
- For replacement stem information, contact Victaulic

Size		Dimensions				Approx. Weight Each
Nominal Size Inches mm	Actual Outside Diameter Inches mm	A End to End Inches mm	B Inches mm	C Inches mm	E Inches mm	Lbs. kg
½*	0.840	7.98	2.36	0.88	5.12	1.5
15	21.3	200.0	59.9	22.4	130.0	0.7
¾	1.050	8.57	2.52	1.00	5.12	2.4
20	26.7	217.2	64.0	25.4	130.0	1.1
1	1.315	8.89	2.80	1.00	6.50	3.6
25	33.7	225.8	71.1	25.4	165.1	1.6
1½	1.900	11.20	3.39	1.50	7.48	6.9
40	48.3	284.5	86.1	38.1	190.0	3.1
2	2.375	12.52	3.74	1.88	7.48	9.5
50	60.3	318.0	95.0	47.8	190.0	4.3

* ½"/15 mm only available in plain end x plain end.

IMPORTANT NOTE:

For dimensions and weights with gear operator contact Victaulic.

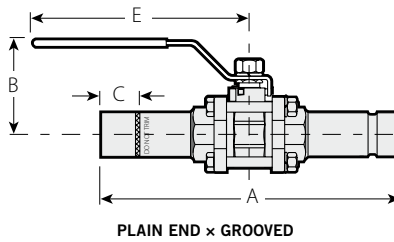
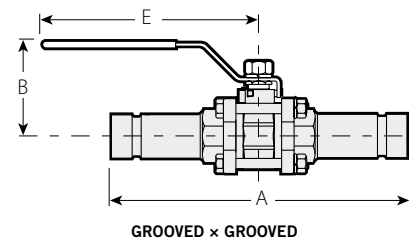
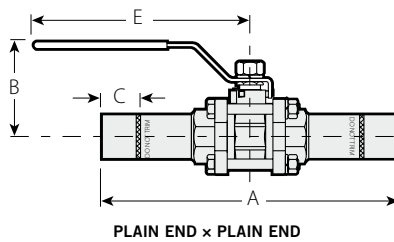

REPAIR KITS AND REPLACEMENT PARTS FOR SERIES 569 BALL VALVE

Size		Repair Kit	Replacement Ball
Nominal Size Inches mm	Actual Outside Diameter Inches mm	Part No.	Part No.
½	0.840	K-004-569-001	K-004-569-000
15	21.3		
¾	1.050	K-006-569-001	K-006-569-000
20	26.7		
1	1.315	K-010-569-001	K-010-569-000
25	33.7		
1½	1.900	K-014-569-001	K-014-569-000
40	48.3		
2	2.375	K-020-569-001	K-020-569-000
50	60.3		

Plain End Piping System for HDPE Pipe

- Victaulic HDPE products have integral rows of gripping teeth that bite into the entire circumference of the HDPE pipe
- Eliminates the need for special heat fusion, solvent joining or special adapters
- Victaulic products are rated to the working pressure of the pipe
- Fast, easiest way to mechanically join HDPE pipe at wall thicknesses from SDR 32.5 to 7.3
- Sizes from 2–20"/50–500 mm
- Up to seven times faster than fusion welding

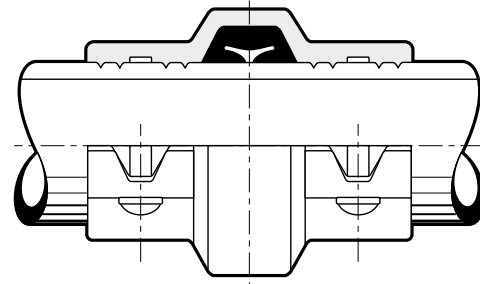

EXAGGERATED FOR CLARITY

IMPORTANT NOTES:

Victaulic HDPE products are not intended for use on PVC pipe or other materials
Victaulic lubricant should **NOT** be used with HDPE pipe

Coupling

STYLE 995, PG. 10-2



Transition Coupling – HDPE to Steel

STYLE 997, PG. 10-3



Vic-Flange Adapter ANSI Class 150

STYLE 994, PG. 10-4



PRODUCTS

- 1-1 Couplings
- 2-1 Fittings
- 3-1 Valves
- 4-1 Accessories
- 5-1 Advanced Groove System
- 6-1 Hole Cut Piping System
- 7-1 Plain End Piping System
- 8-1 Grooved System for Stainless Steel Pipe
- 9-1 Pressfit System for Stainless Steel Pipe

10-1 Plain End Piping System for HDPE Pipe

- 11-1 Grooved Copper
- 12-1 PermaLynx System for Copper Tube
- 13-1 Grooved AWWA Ductile Iron Pipe
- 14-1 Victaulic Depend-O-Lok® System
- 15-1 Aquamine Reusable PVC Products
- 16-1 Gaskets
- 17-1 Pipe Preparation Tools
- 18-1 Product Index
- 19-1 Piping Software

HDPE Pipe Dimensions

Size		Dimensions		
Nominal Size Inches mm	Actual Outside Diameter Inches mm	Outside Diameter		Maximum Out of Round Tol.* Inches mm
		Size Inches mm	Tol.* Inches mm	
2 50	2.375 60.3	2.375 60.3	± 0.016 0.406	± 0.040 1.016
3 80	3.500 88.9	3.500 88.9	± 0.016 0.406	± 0.040 1.016
4 100	4.500 114.3	4.500 114.3	± 0.020 0.508	± 0.040 1.016
5 125	5.563 141.3	5.563 141.3	± 0.025 0.635	± 0.050 1.270
6 150	6.625 168.3	6.625 168.3	± 0.030 0.762	± 0.050 1.270
8 200	8.625 219.1	8.625 219.1	± 0.039 0.990	± 0.075 1.905

Size		Dimensions		
Nominal Size Inches mm	Actual Outside Diameter Inches mm	Outside Diameter		Maximum Out of Round Tol.* Inches mm
		Size Inches mm	Tol.* Inches mm	
10 250	10.750 273.0	10.750 273.0	± 0.048 1.219	± 0.075 1.905
12 300	12.750 323.9	12.750 323.9	± 0.057 1.448	± 0.075 1.905
14 † 350	14.000 355.6	14.000 355.6	± 0.063 1.600	± 0.075 1.905
16 400	16.000 406.4	16.000 406.4	± 0.072 1.830	§
18 450	18.000 457.0	18.000 457.0	± 0.081 2.060	§
20 500	20.000 508.0	20.000 508.0	± 0.090 2.290	§

* At ambient temperatures.
§ See pipe manufacturer for maximum out of round tolerance.
† Contact Victaulic for special bolt/nut requirements.

Plain End Piping System for HDPE Pipe

Coupling

STYLE 995

For Complete Information
Request Publication 19.02



- Sharp gripping teeth on both housing sides grip into outside diameter of HDPE pipe
- Design permits direct joining without fusing equipment
- Up to seven times faster than fusion welding
- No special pipe preparation required
- Sizes from 2–20"/50–500mm

Size		Dimensions			Approx. Weight Each
Nominal Size Inches mm	Actual Outside Diameter Inches mm	X Inches mm	Y Inches mm	Z Inches mm	Lbs. kg
2	2.375	3.69	5.94	3.63	3.5
50	60.3	94	151	92	1.6
3	3.500	4.63	7.00	4.56	7.7
80	88.9	118	178	116	3.5
90†	90.9	116	178	116	3.4
110†	111.0	145	202	146	5.3
4	4.500	5.88	8.13	5.81	11.6
100	114.3	149	207	148	5.3
140†	141.3	176	250	149	6.8
5	5.563	6.94	9.88	5.88	15.0
125	141.3	176	251	149	6.8
160†	161.5	195	268	149	7.3
6	6.625	8.00	10.88	5.88	16.4
150	168.3	203	276	149	7.4
200†	201.8	259	336	152	9.7
8	8.625	10.19	13.25	6.00	24.9
200	219.1	259	377	152	11.3
225†	227.1	265	345	152	10.9
250†	252.3	314	402	165	17.0
10	10.750	12.38	15.88	6.50	37.4
250	273.0	314	403	165	17.0
280†	282.6	321	408	165	17.6
315†	317.9	356	448	178	20.7
12	12.750	14.38	18.00	7.00	49.0
300	323.9	365	457	178	22.2
14	14.000	16.25	19.88	8.58	81.0
350	355.6	413	505	218	36.7
355†	358.2	414	525	218	36.7
400†	403.6	465	605	229	45.5
16	16.000	18.30	23.88	9.00	100.0
400	406.4	465	607	229	45.5
450†	453.8	516	650	241	57.7
18	18.000	20.30	25.63	9.50	127.0
450	457.0	516	651	241	57.7
500†	504.0	566	699	254	64.5
20	20.000	22.30	27.44	10.00	142.0
500	508.0	566	697	254	64.5

† Available in metric sizes only.

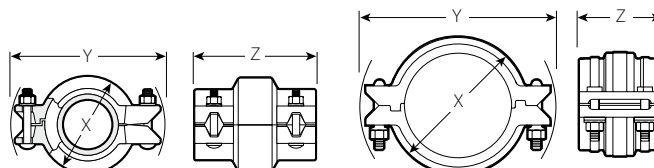

TYPICAL 3–12"/80–300mm SIZES
(2"/50mm HAS ONE BOLT PER SIDE)

TYPICAL 14–20"/350–500mm SIZES

Plain End Piping System for HDPE Pipe

Transition Coupling – HDPE to Steel

STYLE 997

For Complete Information
Request Publication 19.03



Size		Dimensions			Approx. Weight Each
Nominal Size Inches mm	Actual Outside Diameter Inches mm	X Inches mm	Y Inches mm	Z Inches mm	Lbs. kg
2	2.375	3.31	5.22	2.78	3.0
50	60.3	84	133	71	1.4
3	3.500	4.38	6.99	3.20	6.6
80	88.9	111	178	81	3.0
4	4.500	5.68	8.25	3.90	8.7
100	114.3	144	210	99	4.0
5	5.563	6.75	9.77	3.97	11.5
125	141.3	172	248	101	5.2
6	6.625	7.84	11.25	4.00	14.8
150	168.3	199	286	102	6.7
8	8.625	10.18	13.96	4.16	21.7
200	219.1	259	355	106	9.8
10	10.750	12.63	16.81	4.56	34.3
250	273.0	321	427	116	15.6
12	12.750	14.58	18.76	4.85	37.5
300	323.9	370	477	123	17.0



- Fastest and easiest way to join plain end HDPE pipe to grooved IPS pipe, valves, and fittings
- Designed for use with HDPE with pipe wall thickness from SDR 32.5 to 7.3
- Grooved side has conventional key section to engage standard roll or cut grooved IPS pipe of same size as mating HDPE pipe
- Up to seven times faster than fusion welding
- No special pipe preparation required
- Sizes from 2–12"/50–300mm

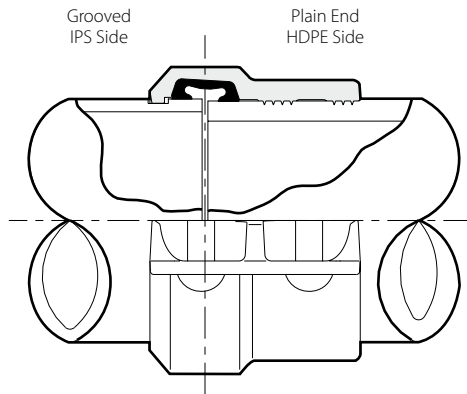

EXAGGERATED FOR CLARITY

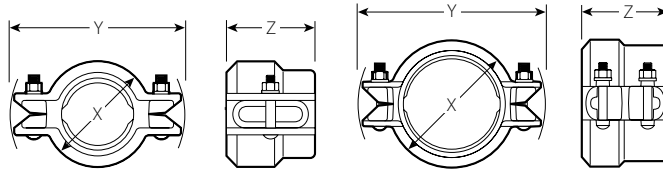

TYPICAL 2"/50 mm SIZE

TYPICAL 3–12"/80–300 mm SIZES

Plain End Piping System for HDPE Pipe

Vic-Flange Adapter ANSI Class 150

STYLE 994

For Complete Information
Request Publication **19.04**



- Permits direct connection of ANSI Class 125 and 150 flanged components into HDPE systems
- Up to seven times faster than fusion welding
- No special pipe preparation required
- Sizes from 4–8"/100–200 mm

Size		Sealing Surface*		Dimensions		Approx. Weight Each
Nominal Size Inches mm	Actual Outside Diameter Inches mm	A Minimum Inches mm	B Maximum Inches mm	X Inches mm	Z Inches mm	Lbs. kg
4 100	4.500 114.3	4.50 114	5.78 147	9.00 229	3.38 86	12.5 5.7
6 150	6.625 168.3	6.63 168	7.97 202	11.00 279	4.00 102	17.3 7.8
8 200	8.625 219.1	8.63 220	10.00 254	13.50 343	4.50 114	30.8 14.0

* Minimum/maximum sealing surface on mating flange must be available for proper gasket seating. Entire area must be flat. Heavy serrated (phonograph record) finishes are not acceptable. When used with rubber seated wafer butterfly valves, a flat metal adapter plate is needed.

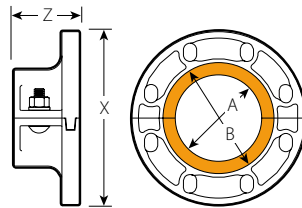

TYPICAL FOR ALL SIZES

Orange area of mating face must be free from gouges, undulations or deformities of any type for effective sealing.

Grooved Copper

- Cold formed system eliminates the need for soldering or brazing
- Full line of couplings, fittings and valves for systems rated to 300 psi/2065 kPa
- Line of roll grooving tools available for on-site grooving
- Copper connection system joins 2–8" / 50–200mm Type K, L, M, or DWV copper



Couplings

QuickVic® Rigid Coupling

STYLE 607, PG. 11-3



Rigid Coupling

STYLE 606, PG. 11-4



Vic-Flange Adapter

STYLE 641, PG. 11-4



PRODUCTS

- 1-1 Couplings
- 2-1 Fittings
- 3-1 Valves
- 4-1 Accessories
- 5-1 Advanced Groove System
- 6-1 Hole Cut Piping System
- 7-1 Plain End Piping System
- 8-1 Grooved System for Stainless Steel Pipe
- 9-1 Pressfit System for Stainless Steel Pipe
- 10-1 Plain End Piping System for HDPE Pipe

11-1 Grooved Copper

- 12-1 PermaLynx System for Copper Tube
- 13-1 Grooved AWWA Ductile Iron Pipe
- 14-1 Victaulic Depend-O-Lok® System
- 15-1 Aquamine Reusable PVC Products
- 16-1 Gaskets
- 17-1 Pipe Preparation Tools
- 18-1 Product Index
- 19-1 Piping Software

Mechanical-T Bolted Branch Outlet

STYLE 622, PG. 11-5



Mechanical-T Bolted Branch Crosses

STYLE 622, PG. 11-5



Valves

Butterfly Valve

SERIES 608, PG. 11-9



Grooved Copper

Fittings



90° Elbow
NO. 610, PG. 11-6

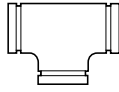

Tee
NO. 620, PG. 11-6

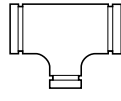

Reducing Tee
Grv. × Grv. × Grv.
NO. 625, PG. 11-8

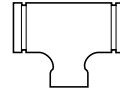

Reducing Tee
Grv. × Grv. × Cup
NO. 626, PG. 11-8



45° Elbow
NO. 611, PG. 11-6



Concentric Reducer
Grv. × Grv.
NO. 650, PG. 11-7

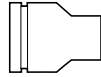

Concentric Reducer
Grv. × Cup
NO. 652, PG. 11-7



Cap
NO. 660, PG. 11-6

Grooved Copper – Couplings

Performance

The Victaulic copper connection system has been thoroughly tested on Types K, L, M, and DWV copper tubing. Victaulic products are routinely tested to failure in unrestrained hydrostatic and flexure tests. Using our normal minimum 3-to-1 safety factor, these tests provided regular verification of the product working pressures. The ratings in this table apply to all copper connection products for the indicated types of tubing.

Size	Type "K" ASTM B-88			Type "L" ASTM B-88			Type "M" ASTM B-88			DWV ASTM B-306		
	Nominal Inches Actual mm	Wall Thick. Inches mm	Max. Joint Working Press. psi kPa	Max. Permis. End Load Lbs. N	Wall Thick. Inches mm	Max. Joint Working Press. psi kPa	Max. Permis. End Load Lbs. N	Wall Thick. Inches mm	Max. Joint Working Press. psi kPa	Max. Permis. End Load Lbs. N	Wall Thick. Inches mm	Max. Joint Working Press. psi kPa
2 54.0	0.083 2.1	300 2065	1,065 4740	0.070 1.8	300 2065	1,065 4740	0.058 1.5	250 1725	890 3960	0.042 1.1	100 690	354 1576
2 1/2 66.7	0.095 2.4	300 2065	1,625 7230	0.080 2.0	300 2065	1,625 7230	0.065 1.7	250 1725	1,350 6010	—	—	—
3 79.4	0.109 2.8	300 2065	2,300 10235	0.090 2.3	300 2065	2,300 10235	0.072 1.8	250 1725	1,415 6300	0.045 1.1	100 690	765 3405
4 104.8	0.134 3.4	300 2065	4,005 17825	0.110 2.8	300 2065	4,005 17825	0.095 2.4	250 1725	3,340 14865	0.058 1.5	100 690	1,335 5940
5 130.2	0.160 4.1	300 2065	6,190 27550	0.125 3.2	300 2065	6,190 27550	0.109 2.8	20 1375	4,125 18360	0.072 1.8	100 690	2,060 9170
6 155.6	0.192 4.9	300 2065	8,840 39340	0.140 3.6	300 2065	8,840 39340	0.122 3.1	200 1375	5,890 26210	0.083 2.1	100 690	2,945 13105
8 206.4	0.271 6.9	300 2065	15,550 69200	0.200 5.1	300 2065	15,550 69200	0.170 4.3	200 1375	10,370 46,100	0.109 2.8	100 690	5,180 23000

Working Pressure and End Load are total, from all internal and external loads, based on the indicated type of copper tubing, standard roll grooved in accordance with Victaulic specifications.

IMPORTANT NOTE:

For one time field test only, the Maximum Joint Working Pressure may be increased to 1½ times the figures shown.

WARNING: Depressurize and drain the piping system before attempting to install, remove, or adjust any Victaulic piping products.

Grooved Copper – Couplings

QuickVic® Rigid Coupling

STYLE 607

For Complete Information Request Publication **22.13**



- Installation-ready design
- Eliminates brazing and soldering
- Angled-pad design creates a rigid joint
- Pressure rated up to 300 psi/2065kPa
- Sizes from 2-4"/50-100mm to fit copper tubing (CTS)

Size	Allow. Pipe End Sep. †	@ Bolt/Nut No. – Size	Dimensions – Inches/mm					Aprx. Wgt. Ea.
			Pre-assembled (Installation-ready condition)		Joint Assembled			
			X	Y	X	Y	Z	
2 54.0	0.16 4	2 – 3/8 x 2 1/2	3.63 92	5.50 138	3.38 86	5.50 138	2.00 51	1.9 0.9
2 1/2 66.7	0.16 4	2 – 3/8 x 2 1/2	4.19 106	6.00 152	3.94 100	6.00 152	2.00 51	2.2 1.0
3 79.4	0.16 4	2 – 1/2 x 3	4.75 121	7.00 178	4.50 114	7.00 178	2.00 51	3.0 1.4
4 104.8	0.16 4	2 – 1/2 x 3	5.63 143	8.00 203	5.38 137	8.00 203	2.00 51	3.6 1.6
5 130.2	0.16 4	2 – 5/8 x 3 1/4	6.63 168	9.63 245	6.38 163	9.63 245	2.00 51	5.2 2.4
6 155.6	0.16 4	2 – 5/8 x 3 1/4	7.75 197	10.63 270	7.50 191	10.63 270	2.00 51	5.8 2.6
8 206.4	0.16 4	2 – 5/8 x 4	9.88 251	12.75 324	9.63 245	12.75 324	2.00 51	7.7 3.5

† The allowable pipe separation dimension shown is for system layout purposes only. Style 607 QuickVic rigid couplings for copper are considered rigid connections and will not accommodate expansion or contraction of the piping system.

@ Number of bolts required equals number of housing segments.

WARNING: Depressurize and drain the piping system before attempting to install, remove or adjust any Victaulic piping products.

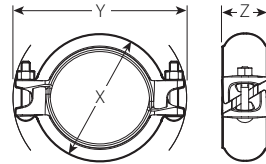

STYLE 607 PRE-ASSEMBLED (INSTALLATION-READY CONDITION)

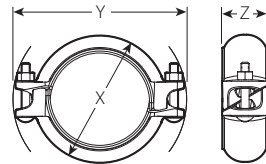

STYLE 607 JOINT ASSEMBLED

Grooved Copper – Couplings

Rigid Coupling

STYLE 606

For Complete Information
Request Publication 22.02



- Eliminates brazing or soldering
- Unique patented angled-pad creates a rigid joint
- Available for:
 - British Standard (BS) Request publication 22.08
 - DIN Standard (DIN) Request publication 22.09
 - Australian Standard (AS) Request publication 22.10
- Pressure rated up to 300 psi/2065 kPa
- Sizes from 2–8”/54–206.4 mm to fit copper tubing (CTS)

Size	Allow Pipe End Sep. #	Dimensions			Approx. Weight Each
		Nominal Inches Actual mm	X Inches mm	Y Inches mm	
2 54.0	0.06 1.5	3.17 81	4.86 123	1.75 45	1.5 0.7
2½ 66.7	0.06 1.5	3.67 93	5.34 136	1.75 45	2.0 0.9
3 79.4	0.06 1.5	4.17 106	6.50 165	1.75 45	2.2 1.0
4 104.8	0.06 1.5	5.17 131	7.34 186	1.75 45	3.2 1.5
5 130.2	0.06 1.5	6.23 158	9.21 234	1.75 45	4.9 2.2
6 155.6	0.06 1.5	7.20 183	10.13 257	1.75 45	5.7 2.6
8 206.4	0.06 1.5	9.40 239	12.42 315	1.88 48	7.2 3.3

For field installation only. Style 606 is essentially rigid and does not permit expansion/contraction.

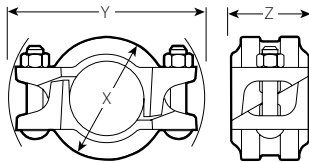

TYPICAL FOR ALL SIZES

Vic-Flange Adapter

STYLE 641

For Complete Information
Request Publication 22.03



- Direct connection from flanged components to grooved copper tubing
- Integral tabs ease handling
- For 2–6”/54.0–155.6 mm K, L, M, or DWV tubing

Size	Sealing Surface		Dimensions				Approx. Weight Each
	A Maximum Inches mm	B Minimum Inches mm	W Inches mm	X Inches mm	Y Inches mm	Z Inches mm	
2 54.0	2.13 54	3.20 81	6.88 175	6.00 152	4.75 121	0.78 20	3.8 1.7
2½ 66.7	2.63 67	3.91 99	7.88 200	7.00 178	5.50 140	0.88 22	4.7 2.1
3 79.4	3.13 80	4.53 115	8.44 214	7.50 191	6.00 152	0.94 24	5.4 2.5
4 104.8	4.13 105	5.53 140	9.94 253	9.00 229	7.50 191	0.94 24	7.7 3.5
5 130.2	5.13 130	6.71 170	11.00 279	10.00 254	8.50 216	1.00 25	9.3 4.2
6 155.6	6.13 156	7.78 198	12.00 305	11.00 279	9.50 241	1.00 25	10.3 4.7

IMPORTANT NOTE:

Style 641 Vic-Flange adapters for copper tubing provide rigid joints when used on copper tubing that is roll grooved to Victaulic dimensions and consequently allow no linear or angular movement at the joint.

For restrictions on where and how Vic-Flange adapters and flange washers can be used, refer to Publication 22.03.

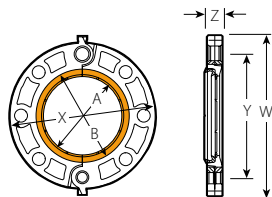

TYPICAL FOR ALL SIZES

Orange area of mating face must be free from gouges, undulations or deformities of any type for effective sealing.

Grooved Copper

Mechanical-T Bolted Branch Outlet

STYLE 622

For Complete Information
Request Publication **22.12**



Size		Dimensions						Approx. Weight Each
Run x Branch Nominal Size		Hole Diameter	T **	V ‡	W	Y	Z	Lbs. kg
Inches		+0.13	Inches	Thd.	Inches	Inches	Inches	
mm		-0.00	mm	mm	mm	mm	mm	
2½ 65	¾ 20	1.50	2.05	2.61	1.73	5.90	2.75	3.1
		38	52	66	44	150	70	1.4
	1 25	1.50	1.93	2.61	1.73	5.90	2.75	3.2
		38	49	66	44	150	70	1.5
	1½ 40	2.00	2.15	2.87	1.73	6.06	3.38	4.1
		51	55	73	44	154	86	1.9
3 80	¾ 20	1.50	2.30	2.86	2.09	6.30	2.75	3.4
		38	58	73	53	160	70	1.5
	1 25	1.50	2.19	2.87	2.09	6.30	2.75	3.6
		38	56	73	53	160	70	1.6
	1½ 40	2.00	2.59	3.31	2.09	6.30	3.38	4.5
		51	66	84	53	160	86	2.0
4 100	¾ 20	1.50	2.81	3.37	2.50	7.25	2.75	3.3
		38	71	86	64	184	70	1.7
	1 25	1.50	2.69	3.37	2.50	7.25	2.75	4.0
		38	68	86	64	184	70	1.8
	1½ 40	2.00	3.09	3.81	2.50	7.25	3.38	5.0
		51	79	97	64	184	86	2.3

** Center of run to engaged pipe end, female threaded outlet only (dimensions approximate).

‡ Center of run to end of fitting.

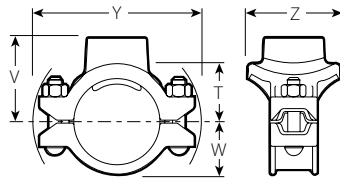

GROOVED COPPER

Mechanical-T Bolted Branch Crosses

STYLE 622

For Complete Information
Request Publication **22.12**

- Combination of upper housings from Style 622 Mechanical-T
- Available in sizes from 2½–4"/65–100mm
- Working pressure equivalent to Style 622 Mechanical-T



Grooved Copper – Fittings

Elbows, Tee and Cap

- NO. 610** 90° Elbow
- NO. 611** 45° Elbow
- NO. 620** Tee
- NO. 660** Cap

For Complete Information Request Publication **22.04**

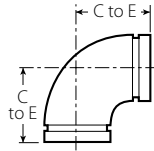

NO. 610

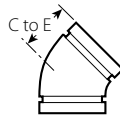

NO. 611

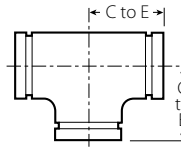

NO. 620



NO. 660

Size	No. 610 90° Elbow		No. 611 45° Elbow		No. 620 Tee		No. 660 Cap	
	Nominal Inches Actual mm	C to E Inches mm	Approx. Weight Each Lbs. kg	C to E Inches mm	Approx. Weight Each Lbs. kg	C to E Inches mm	Approx. Weight Each Lbs. kg	T Inches mm
2 54.0	2.91 74	0.9 0.4	2.19 56	0.8 0.4	2.69 62	1.1 c 0.5	0.96 24	1.2 c 0.5
2½ 66.7	3.31 84	1.3 0.6	2.31 59	1.1 0.5	3.20 81	1.8 c 0.8	0.96 24	1.4 c 0.6
3 79.4	3.81 97	4.1 c 1.9	2.59 66	1.6 0.7	3.52 89	3.2 c 1.5	0.96 24	1.4 c 0.6
4 104.8	4.75 121	6.7 c 3.0	3.19 81	3.4 1.5	4.25 108	6.1 c 2.8	0.96 24	2.4 c 1.1
5 130.2	5.94 151	15.0 c 6.8	3.25 83	10.0 c 4.5	5.94 151	18.5 c 8.4	0.96 24	3.5 c 1.6
6 155.6	6.94 176	20.0 c 9.1	3.63 92	13.0 c 5.9	6.94 176	25.5 c 11.6	0.96 24	4.2 c 1.9
8 206.4	7.75 197	26.0 c 11.8	4.25 108	15.6 c 7.1	7.75 197	45.0 c 20.4	—	—

c = Bronze casting; all others, drawn copper.

- Full flow standard radius copper fittings are supplied as either roll grooved wrought copper or bronze castings
- Designed for installation into copper systems using either a Style 606 coupling or Style 641 Vic-Flange adapter
- Pressures rates up to 300 psi/2065 kPa
- Sizes from 2–8"/54.0–206.4 mm

Grooved Copper – Fittings

Concentric Reducer

NO. 650 Grv. × Grv.

NO. 652 Grv. × Cup

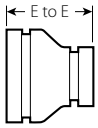

NO. 650

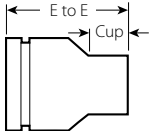

NO. 652

Size		No. 650 Grv. × Grv.		No. 652 Grv. × Cup			
Nominal Inches Actual mm		E to E Inches mm	Approx. Wgt. Each Lbs. kg	E to E Inches mm	Cup Inches mm	Approx. Wgt. Each Lbs. kg	
2 54.0	×	1 28.6	—	2.70 69	0.91 23	0.50 0.2	
		1¼ 34.9	—	3.00 76	0.97 25	0.45 0.2	
		1½ 41.3	—	2.94 75	1.09 28	0.45 0.2	
2½ 66.7	×	1 28.6	—	3.25 83	0.91 23	0.78 0.4	
		1¼ 34.9	—	3.52 89	0.97 25	0.60 0.3	
		1½ 41.3	—	3.45 88	1.09 28	0.65 0.3	
		2 54.0	3.29 83	1.00 0.5	3.30 84	1.34 34	0.65 0.3
3 79.4	×	1½ 41.3	—	3.68 93	1.09 28	1.06 0.5	
		2 54.0	2.50 64	0.95 c 0.4	4.10 104	1.34 34	0.99 0.5
		2½ 66.7	2.50 64	0.92 0.4	—	—	—
4 104.8	×	2 54.0	4.75 121	1.65 c 0.8	4.75 121	1.34 34	1.95 0.9
		2½ 66.7	3.00 76	1.95 c 0.9	—	—	—
		3 79.4	3.00 76	2.02 0.9	—	—	—
5 130.2	×	3 79.4	3.88 99	6.30 c 2.9	—	—	
		4 104.8	3.38 86	6.30 c 2.9	—	—	
6 155.6	×	3 79.4	4.38 111	6.40 c 2.9	—	—	
		4 104.8	3.88 99	6.50 c 2.9	—	—	
		5 130.2	3.38 86	6.70 c 3.0	—	—	
8 206.4	×	6 155.6	5.00 127	10.0 c 4.5	—	—	

c = Bronze casting; all others, drawn copper.

Grooved Copper – Fittings

Reducing Tee

NO. 625 Grv. x Grv. x Grv.

NO. 626 Grv. x Grv. x Cup

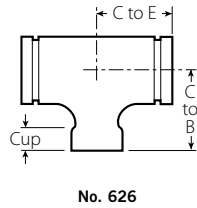
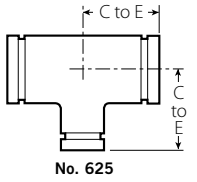

Size			No. 625 Grv. x Grv. x Grv.			No. 626 Grv. x Grv. x Cup				
Nominal Inches			C to E	C to B	Approx. Wgt.	C to E	C to B	Cup	Approx. Wgt.	
Actual mm	Inches	mm	Inches	Inches	Lbs. kg	Inches	Inches	Inches	Lbs. kg	
2 54.0	x	2 54.0	x	3/4 22.5	—	—	2.20 56	1.98 50	0.75 19	0.75 0.3
				1 28.6	—	—	2.33 59	2.20 56	0.91 23	0.81 0.4
				1 1/4 34.9	—	—	2.48 63	2.35 60	0.97 25	0.85 0.4
				1 1/2 41.3	—	—	2.55 65	2.28 58	1.09 28	0.87 0.4
				2 54.0	3.00 76	3.38 86	2.14 c 1.0	—	—	—
2 1/2 66.7	x	2 1/2 66.7	x	3/4 22.5	—	—	2.26 57	2.23 57	0.75 19	1.00 0.5
				1 28.6	—	—	2.40 61	2.40 61	0.91 23	1.17 0.5
				1 1/4 34.9	—	—	2.52 64	2.57 65	0.97 25	1.23 0.5
				1 1/2 41.3	—	—	2.70 69	2.68 68	1.09 28	1.32 0.6
				2 54.0	3.25 83	3.50 89	2.43 c 1.1	—	—	—
3 79.4	x	3 79.4	x	3/4 22.5	—	—	2.41 61	2.56 65	0.75 19	1.40 0.6
				1 28.6	—	—	2.54 65	2.79 71	0.91 23	1.45 0.7
				1 1/4 34.9	—	—	2.63 67	2.89 73	0.97 25	1.74 0.8
				1 1/2 41.3	—	—	2.85 73	3.00 76	1.09 28	1.74 0.8
				2 54.0	3.00 76	3.38 86	2.14 c 1.0	—	—	—
4 104.8	x	4 104.8	x	3/4 22.5	—	—	3.04 77	2.97 75	0.75 19	2.75 1.2
				1 22.5	—	—	3.10 79	3.22 82	0.91 23	2.86 1.3
				1 1/4 34.9	—	—	3.25 83	3.47 88	0.97 25	3.03 1.4
				1 1/2 41.3	—	—	3.35 85	3.65 93	1.09 28	3.16 1.4
				2 54.0	3.66 93	4.13 105	5.25 c 2.4	—	—	—
5 130.2	x	5 130.2	x	3 79.4	3.75 95	4.63 118	5.41 c 2.5	—	—	—
				4 104.8	4.25 108	4.56 116	8.75 c 4.0	—	—	—
				2 1/2 66.7	3.63 92	5.13 130	6.66 c 3.0	—	—	—
				3 79.4	3.69 94	5.19 132	8.12 c 3.7	—	—	—
				4 104.8	4.19 106	5.13 130	9.75 c 4.4	—	—	—
6 155.6	x	6 155.6	x	2 1/2 66.7	3.63 92	5.13 130	6.66 c 3.0	—	—	—
				3 79.4	3.69 94	5.19 132	8.12 c 3.7	—	—	—
				4 104.8	4.19 106	5.13 130	9.75 c 4.4	—	—	—
				5 130.2	4.69 119	5.19 132	11.25 c 5.1	—	—	—

c = Bronze casting; all others, drawn copper.

Grooved Copper – Valves

Butterfly Valve

SERIES 608

For Complete Information
Request Publication 22.05



Size	Dimensions									Approx. Wgt. Each	Flow Coefficient@ (Fully Open)
	Nominal Inches Actual mm	A End to End Inches mm	B Inches mm	C Inches mm	D Inches mm	E Inches mm	F Inches mm	G Inches mm	H Inches mm		
2½ 66.7	3.77 96	6.12 155	1.81 46	3.02 77	—	2.63 67	2.25 57	2.31 59	4.4 2.0	325 281.1	
3 79.4	3.77 96	6.58 167	2.06 52	3.33 85	0.08 2	3.13 79	2.54 65	2.31 59	5.1 2.3	480 415.2	
4 104.8	4.63 118	9.25 235	2.75 70	5.15 131	0.13 3	4.13 105	3.19 81	2.82 72	10.5 4.8	600 519.0	
5 130.2	5.88 149	10.13 257	3.12 79	5.67 144	0.50 13	5.13 130	3.75 95	4.00 102	14.0 6.4	1150 994.8	
6 155.6	5.88 149	11.15 283	3.62 92	6.25 159	1.00 25	6.13 156	4.16 106	4.00 102	19.0 8.6	1850 1600.3	

@ C_v/K_v values for flow of water at +60°F/+16°C with a fully open valve.

IMPORTANT NOTE:

All Series 608 butterfly valves are bronze castings.

- Dead end service provided to full working pressure in both directions
- Pressure rated up to 300 psi/2065 kPa bubble-tight shut-off
- Sizes from 2½–6"/66.7–155.6 mm CTS

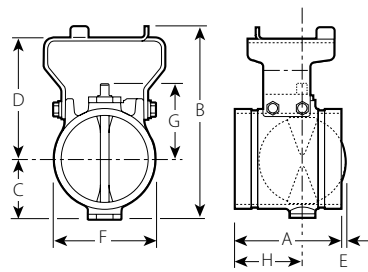

TYPICAL 2½–3"/66.7–79.4 mm SIZES

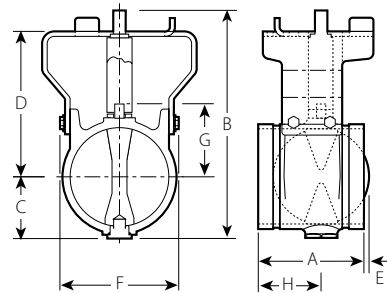

TYPICAL 4–5"/104.8–130.2 mm SIZES

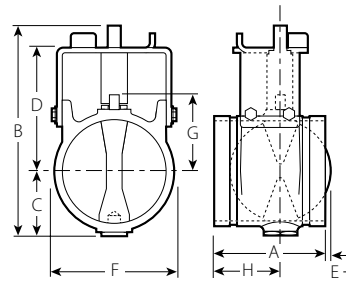

TYPICAL 6"/155.6 mm SIZES

Lined writing area with horizontal lines.

GROOVED COPPER

PermaLynx System for Copper Tube



Align



Insert



Push-to Connect

The Victaulic PermaLynx product line offers a complete system of push-to-connect couplings, fittings, valves and specialty adapters for ½- 1 ½"/15-40 mm for ASTM B88 hard-drawn (K, L & M) copper tube.

The PermaLynx system is rated to 200 psi/1380 kPa* and is recommended for use in potable hot and cold water distribution systems up to 180 F/82 C. In addition, PermaLynx products are recommended for use in ambient, oil-free compressed air systems.

For complete information, request publication 22.20.

*All PermaLynx products are rated to 200 psi/1380 kPa with the exception of the supply stop valve which is rated to 125 psi/860 kPa.

PermaLynx Products

- Push-to-connect technology offers a safer alternative to a solder system by providing a flame-free method of installation
- PermaLynx products install twice as fast as sweat and 20% faster than “press” products.
- Fast, easy installation reduces downtime
- Reduces rework on brazed or soldered systems by 10-15%
- Installs on wet lines. No need to drain the system during maintenance or retrofit.

PRODUCTS

- 1-1 Couplings
- 2-1 Fittings
- 3-1 Valves
- 4-1 Accessories
- 5-1 Advanced Groove System
- 6-1 Hole Cut Piping System
- 7-1 Plain End Piping System
- 8-1 Grooved System for Stainless Steel Pipe
- 9-1 Pressfit System for Stainless Steel Pipe
- 10-1 Plain End Piping System for HDPE Pipe
- 11-1 Grooved Copper
- 12-1 PermaLynx System for Copper Tube**
- 13-1 Grooved AWWA Ductile Iron Pipe
- 14-1 Victaulic Depend-O-Lok® System
- 15-1 Aquamine Reusable PVC Products
- 16-1 Gaskets
- 17-1 Pipe Preparation Tools
- 18-1 Product Index
- 19-1 Piping Software

Grooved AWWA Ductile Iron Pipe

- Victaulic grooved piping components are available for use on AWWA C-606 Class 53 pipe or heavier
- Fastest, easiest method for joining AWWA size pipe - 75% fewer bolts than flanging
- FlushSeal® gasket specifically designed to seal on ductile iron pipe surfaces provides triple-seal to promote leak-free service for the life of the system
- Request publication 23.01
- Pressure rated up to 500 psi/3450 kPa
- Sizes from 3–36"/80–900 mm

Grooves can be cut into the pipe to provide a rigid or flexible connection as needed.

Pipe and fittings can be coated for abrasive services.

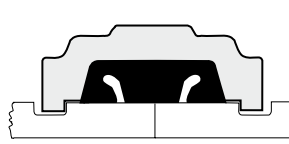

RIGID RADIUS CUT GROOVE

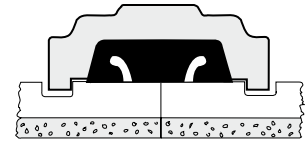

CEMENT LINED PIPE

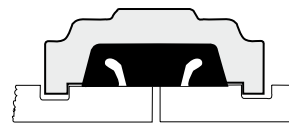

FLEXIBLE RADIUS CUT GROOVE

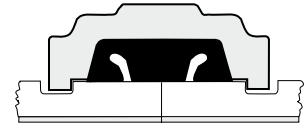

GLASS LINED

Illustrations exaggerated for clarity

GROOVED AWWA DUCTILE IRON PIPE

Elbows

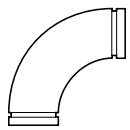

90° Long Radius Elbow
NO. 100-C, PG. 13-7



11 1/4° Elbow
NO. 13-C, PG. 13-7



Base Elbow
NO. 10-CB, PG. 13-13



90° Elbow
NO. 10-C, PG. 13-7



90° Reducing Elbow
NO. 10-CR, PG. 13-11

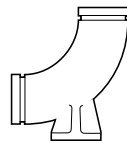

Long Radius Base Elbow
NO. 100-CB, PG. 13-13



45° Elbow
NO. 11-C, PG. 13-7

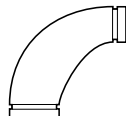

90° Long Radius Reducing Elbow
NO. 100-CR, PG. 13-11



22 1/2° Elbow
NO. 12-C, PG. 13-7

Tees, Crosses, Wyes, and Laterals

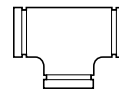

Tee
NO. 20-C, PG. 13-8

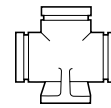

Base Tee
NO. 20-CB, PG. 13-13

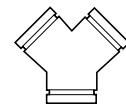

True Wye
NO. 33-C, PG. 13-8

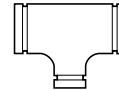

Reducing Tee
NO. 25-C, PG. 13-9

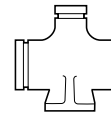

Reducing Base Tee
NO. 25-CB, PG. 13-13

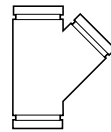

45° Lateral
NO. 30-C, PG. 13-8

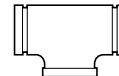

Bullhead Tee
NO. 21-C, PG. 13-8

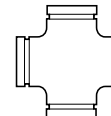

Cross
NO. 35-C, PG. 13-8

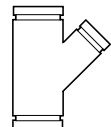

45° Reducing Lateral
NO. 30-CR, PG. 13-9

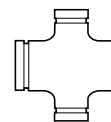

Reducing Cross
NO. 35-CR, PG. 13-9



Cap
NO. 60-C, PG. 13-8

Grooved AWWA Ductile Iron Pipe

Couplings

Coupling
STYLE 31, PG. 13-3



Vic-Flange Adapter
STYLE 341, 13-4



Transition Coupling – AWWA to IPS
STYLE 307, PG. 13-5



Valves

Vic-Plug Valve
SERIES 365, PG. 13-15



Check Valve
SERIES 317, PG. 13-17



Reducers



Concentric Reducer
NO. 50-C, PG. 13-11



Eccentric Reducer
NO. 51-C, PG. 13-11

Flared and Outlet Fittings

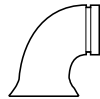

90° Flare
NO. 10-CF, PG. 13-14



Straight Flare
NO. 43-CF, PG. 13-14

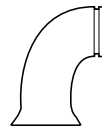

90° Long Radius Flare
NO. 100-CF, PG. 13-14

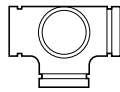

Tee Side Outlet
NO. 20-CS, PG. 13-14



90° Side Outlet
NO. 10-CS, PG. 13-14

PRODUCTS

- 1-1 Couplings
- 2-1 Fittings
- 3-1 Valves
- 4-1 Accessories
- 5-1 Advanced Groove System
- 6-1 Hole Cut Piping System
- 7-1 Plain End Piping System
- 8-1 Grooved System for Stainless Steel Pipe
- 9-1 Pressfit System for Stainless Steel Pipe
- 10-1 Plain End Piping System for HDPE Pipe
- 11-1 Grooved Copper
- 12-1 PermaLynx System for Copper Tube
- 13-1 Grooved AWWA Ductile Iron Pipe**
- 14-1 Victaulic Depend-O-Lok® System
- 15-1 Aquamine Reusable PVC Products
- 16-1 Gaskets
- 17-1 Pipe Preparation Tools
- 18-1 Product Index
- 19-1 Piping Software

Gaskets for Grooved End Ductile/Cast Pipe of AWWA Dimensions

Grade	Temperature Range	Compound	Color Code	General Service Recommendations*
S	-20°F to +180°F -29°C to +82°C	Nitrile	Red Stripe	Specially compounded to conform to ductile pipe surfaces. Recommended for petroleum products, air with oil vapors, vegetable and mineral oils within the specified temperature range; except hot dry air over +140°F/60°C and water over +150°F/66°C. Not recommended for hot water services.
M	-20°F to +200°F -29°C to +93°C	Halogenated Butyl	Brown Stripe	Specially compounded to conform to ductile pipe surfaces. Recommended for water service within the specified temperature range plus a variety of dilute acids, oil-free air and many chemical services. Not recommended for petroleum services.
L	-30°F to +350°F -34°C to +177°C	Silicone	Red Gasket	Recommended for dry heat, air without hydrocarbons to +350°F/177°C and certain chemical services.

* Refer to Victaulic Gasket Selection Guide (Request 05.01) for specific service recommendations. Services listed are Gasket Service Recommendations only. It should be noted that there are services for which these gaskets are not recommended. Reference should always be made to the latest Victaulic Gasket Selection Guide for specific gasket service recommendations and for a listing of services which are not recommended.

Grooved AWWA Ductile Iron Pipe – Couplings

Coupling

STYLE 31

For Complete Information
Request Publication **23.02**



- Can provide a rigid or flexible joint depending on groove position
- Reduces number of bolts by up to 75%
- Pressure rated up to 500 psi/3450 kPa
- Sizes from 3–36"/80–900 mm

Size		Max. Working Pressure *	Max. End Load *	Allow. Pipe End Sep. *	Dimensions			Approx. Weight Each
Nominal Size Inches mm	Actual Outside Dia. Inches mm	psi kPa	Lbs. N	Inches mm	X Inches mm	Y Inches mm	Z Inches mm	Lbs. kg
3	3.960	500	6200	0 – 0.09	5.50	7.63	2.13	4.8
80	100.6	3450	27590	0 – 2.4	140	194	54	2.2
4	4.800	500	9000	0 – 0.09	6.25	9.20	2.09	7.5
100	121.9	3450	40050	0 – 2.4	159	234	53	3.4
6	6.900	400	14950	0 – 0.09	8.28	11.19	2.22	9.4
150	175.3	2750	66528	0 – 2.4	210	284	56	4.3
8	9.050	400	25600	0 – 0.09	10.74	14.33	2.59	16.5
200	229.9	2750	113920	0 – 2.4	273	364	66	7.5
10	11.100	350	33850	0 – 0.16	12.84	16.44	2.75	22.5
250	281.9	2410	150632	0 – 4.0	326	418	70	10.2
12	13.200	350	47900	0 – 0.16	15.27	19.16	2.75	30.0
300	335.3	2410	21150	0 – 4.0	388	487	70	14.0
14	15.300	250	45950	0 – 0.16	17.21	21.96	2.75	40.8
350	388.6	1725	204470	0 – 4.0	437	558	70	18.5
16	17.400	250	59400	0 – 0.25	19.90	23.96	3.50	61.3
400	442.0	1725	264330	0 – 6.4	505	609	89	27.8
18‡	19.500	250	74650	0 – 0.25	22.03	26.33	3.50	80.0
450	495.3	1725	332190	0 – 6.4	560	669	89	36.3
20	21.600	150	54900	0 – 0.25	24.13	28.69	3.50	76.0
500	548.6	1035	244305	0 – 6.4	613	729	89	34.5
24	25.800	150	78400	0 – 0.25	28.31	33.06	3.50	104.0
600	655.3	1035	34880	0 – 6.4	719	840	89	47.2
30	32.000	150	120570	0 – 0.47	35.02	39.39	4.38	162.0
750	812.8	1035	536530	0 – 11.9	890	1001	111	73.5
36	38.300	150	172815	0 – 0.47	41.56	46.04	4.44	200.0
900	972.8	1035	769030	0 – 11.9	1056	1169	113	90.7

* Refer to General Notes on pg. 1-4.

‡ For Class 53 pipe rating is 150 psi/1035 kPa.

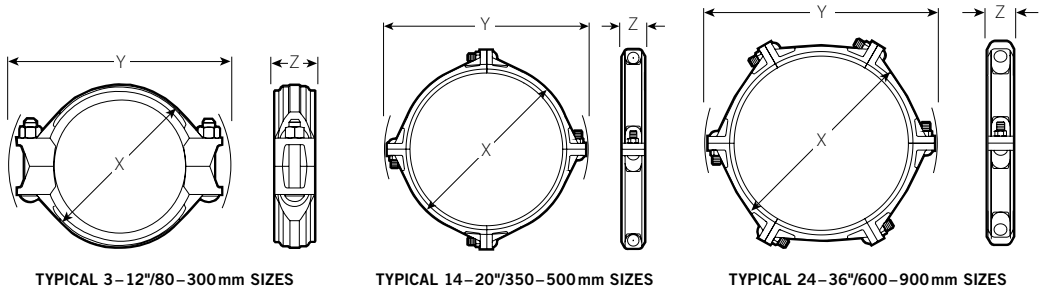

Grooved AWWA Ductile Iron Pipe – Couplings

Vic-Flange Adapter

STYLE 341

For Complete Information
Request Publication 23.04



- Direct connection of flanged components into a radius grooved (to AWWA C-606 standards) cast or ductile iron pipe system
- Provide rigid joint on rigid radius grooved ductile pipe
- Allow limited movement on flexible radius grooved ductile iron pipe
- Pressure rated up to 250 psi/1725 kPa
- Sizes from 3–12"/80–300mm hinged for easy handling with integral tabs
- Sizes from 14–24"/350–600mm cast in four identical segments which are interconnected as assembly is completed

Size		Max. Work Pressure * psi kPa	Max. End Load * Lbs. N	Sealing Surface		Dimensions				Approx. Weight Each Lbs. kg
Nominal Size Inches mm	Actual Outside Dia. Inches mm			A Maximum Inches mm	B Minimum Inches mm	W Inches mm	X Inches mm	Y Inches mm	Z Inches mm	
3 80	3.9600 100.6	250 1725	3100 13795	3.96 101	4.94 125	8.44 214	7.50 191	6.00 152	0.94 24	5.4 2.4
4 100	4.800 121.9	250 1725	4500 20025	4.80 122	5.88 149	9.94 252	9.00 229	7.50 191	0.94 24	8.2 3.7
6 150	6.900 175.3	250 1725	9300 41385	6.90 175	8.00 203	12.00 305	11.00 279	9.50 241	1.00 25	12.0 5.4
8 200	9.050 229.9	250 1725	16000 71200	9.05 230	10.13 257	14.63 372	13.50 343	11.75 298	1.13 29	17.4 7.9
10 250	11.100 281.9	250 1725	23700 105465	11.10 282	12.50 318	17.13 435	16.00 406	14.25 362	1.19 30	24.6 11.2
12 300	13.200 335.3	250 1725	34000 151300	13.20 335	14.75 375	20.13 511	19.00 483	17.00 432	1.25 32	34.4 15.6
14 350	15.300 388.6	200 1375	36700 163315	15.30 389	16.38 416	24.63 626	21.00 533	18.75 476	1.50 38	55.0 25.0
16 400	17.400 442.0	150 1035	35600 158420	17.40 442	18.38 467	27.25 692	23.50 597	21.25 540	1.88 48	80.0 36.3
18 450	19.500 495.3	150 1035	44700 198915	19.50 495	20.00 508	29.13 740	25.00 635	22.75 578	2.25 57	95.0 43.1
20 500	21.600 548.6	150 1035	54900 244305	21.60 549	22.50 572	31.63 803	27.50 699	25.00 635	2.38 61	115.0 52.2
24 600	25.800 655.3	150 1035	78400 348880	25.80 655	27.75 705	36.13 918	32.00 813	29.50 749	2.50 64	150.0 68.0

* Refer to Publication 23.04 for more details.

IMPORTANT NOTE:

Style 341 requires sufficient clearance behind groove to permit proper assembly.

For restrictions on where and how Vic-Flange adapters and flange washers can be used, refer to Publication 23.04.

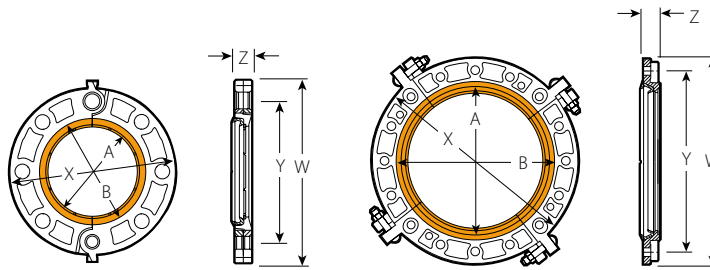

TYPICAL 3–12"/80–300mm SIZES

Orange area of mating face must be free from gouges, undulations or deformities of any type for effective sealing.

TYPICAL 14–24"/350–600mm SIZES

Orange area of mating face must be free from gouges, undulations or deformities of any type for effective sealing.

Grooved AWWA Ductile Iron Pipe – Couplings

Transition Coupling

STYLE 307

Transition for grooved AWWA ductile iron to grooved IPS steel.

For Complete Information
Request Publication **23.03**



Size		Mating Pipe Actual Size		Max. Work Pressure *	Max. End Load *	Fixed End Pipe Sep.*†	Dimensions			Approx. Wgt. Each
Nominal Size Inches mm	Actual Outside Dia. Inches mm	IPS Steel Inches mm	AWWA Ductile Inches mm	psi kPa	Lbs. kg	Inches mm	X Inches mm	Y Inches mm	Z Inches mm	Lbs. kg
3 80	3.960 100.6	3.500 88.9	3.960 100.6	500 3450	4810 21405	0.03 1	5.50 140	7.38 187	2.07 53	6.0 2.7
4 100	4.800 121.9	4.500 114.3	4.800 121.9	500 3450	7950 35377	0.06 2	6.38 162	9.00 229	2.19 56	8.0 3.6
6 150	6.900 175.3	6.625 168.3	6.900 175.3	400 2750	13780 61321	0.06 2	8.44 214	11.13 283	2.31 59	9.0 4.1
8 200	9.050 229.9	8.625 219.1	9.050 229.9	400 2750	23370 103997	0.03 1	11.00 279	13.88 353	2.63 67	18.0 8.2
10 250	11.100 281.9	10.750 273.0	11.100 281.9	350 2410	31760 141332	0.03 1	13.13 334	16.50 419	2.63 67	22.0 10.0
12 300	13.200 335.3	12.750 323.9	13.200 335.3	350 2410	44680 198826	0.03 1	15.38 391	18.94 481	2.63 67	31.0 14.1

† For field installation only. Style 307 transition couplings are essentially rigid and do not permit expansion/contraction.

* Refer to General Notes on pg. 1-4.



- Direct single coupling connection for grooved end IPS steel pipe, valves or fittings to grooved end AWWA ductile iron pipe, valves or fittings of the same nominal size
- Pressure rated up to 500 psi/3450 kPa
- Sizes from 3–12"/80–300mm

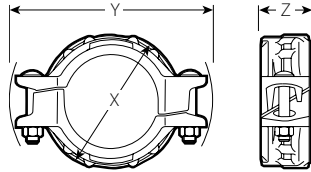

TYPICAL FOR ALL SIZES

Grooved AWWA Ductile Iron Pipe – Fittings

AWWA Fittings

For Complete Information Request Publication **23.05**

- AWWA size fittings are supplied with rigid radius grooves in accordance with ANSI/AWWA C-606
- Fittings conform to ANSI 21.10/AWWA C-110 for center-to-end dimensions and AWWA C-153 or ANSI 21.10/AWWA C-110 for wall thicknesses
- Available with a wide variety of coatings and linings
- Victaulic can supply tapped fittings on order to ANSI B16.1 dimension locations; specify fitting size, tap location by letter (as shown below and tap size – NPT dimensions) on order
- Pressure rated up to 350 psi/2400kPa
- Sizes from 3–36"/80–900mm



Tapped Fittings

Elbows

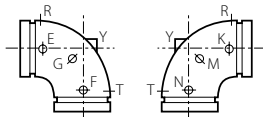

90° ELBOW – STRAIGHT SIZE

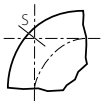

90° ELBOW

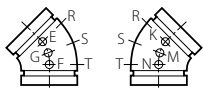

45° ELBOW BASE FITTINGS

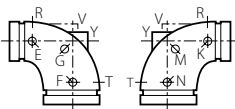

90° ELBOW REDUCING SIZES

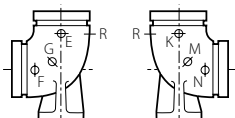

90° BASE ELBOW – STRAIGHT & REDUCING

Tees, Crosses, Wyes, and Laterals

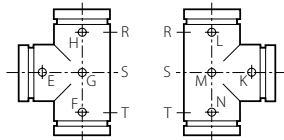

TEE – STRAIGHT SIZES

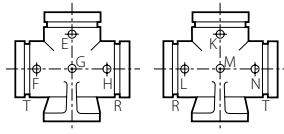

BASE TEE

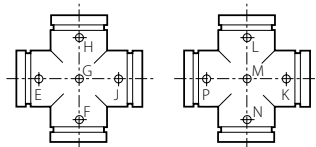

CROSS – STRAIGHT SIZE

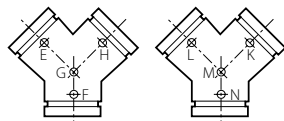

TRUE WYE

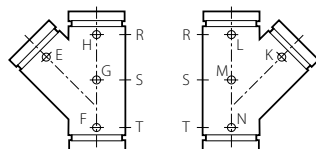

45° LATERAL – STRAIGHT & REDUCING

Reducers

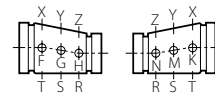

ECCENTRIC REDUCER

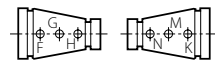

CONCENTRIC REDUCER

Grooved AWWA Ductile Iron Pipe – Fittings

Elbows

- NO. 100-C** 90° Long Radius Elbow
- NO. 10-C** 90° Elbow
- NO. 11-C** 45° Elbow
- NO. 12-C** 22½° Elbow
- NO. 13-C** 11¼° Elbow

For Complete Information
Request Publication **23.05**

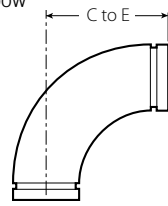

NO. 100-C

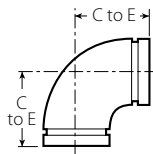

NO. 10-C

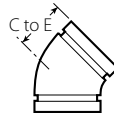

NO. 11-C

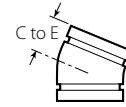

NO. 12-C

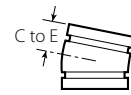

NO. 13-C

Size		No. 100-C 90° Long Radius Elbow		No. 10-C 90° Elbow		No. 11-C 45° Elbow		No. 12-C 22½° Elbow		No. 13-C 11¼° Elbow	
Nominal Size Inches mm	Actual Outside Dia. Inches mm	C to E Inches mm	Approx. Weight Each Lbs. kg	C to E Inches mm	Approx. Weight Each Lbs. kg	C to E Inches mm	Approx. Weight Each Lbs. kg	C to E Inches mm	Approx. Weight Each Lbs. kg	C to E Inches mm	Approx. Weight Each Lbs. kg
3	3.960	7.75	19.3	5.50	8.6	3.00	5.8	3.00	12.5	3.00	9.0
80	100.6	197	8.8	140	3.9	76	2.6	76	5.7	76	4.1
4	4.800	9.00	28.0	6.50	12.0	4.00	8.4	4.00	11.5	4.00	11.5
100	121.9	229	12.7	165	5.4	102	3.8	102	5.2	102	5.2
6	6.900	11.50	55.0	8.00	22.0	5.00	15.0	5.00	25.0	5.00	21.5
150	175.3	292	25.0	203	10.0	127	6.8	127	11.3	127	9.8
8	9.050	14.00	83.0	9.00	38.0	5.50	28.8	5.50	39.5	5.50	39.0
200	229.9	356	37.7	229	17.2	140	13.1	140	17.9	140	17.7
10	11.100	16.50	160.0	11.00	76.0	6.50	43.3	6.50	67.0	6.50	77.0
250	281.9	419	72.6	279	34.5	165	19.6	165	30.4	165	34.9
12	13.200	19.00	210.0	12.00	92.0	7.50	72.0	7.50	108.0	7.50	120.0
300	335.3	483	95.3	305	41.7	191	032.7	191	49.0	191	54.4
14	15.300	21.50	261.0	14.00	174.0	7.50	104.0	7.50	92.0	7.50	101.0
350	388.6	546	118.4	356	78.9	191	47.2	191	41.7	191	45.8
16	17.400	24.00	337.0	15.00	239.0	8.00	142.0	8.00	112.0	8.00	121.0
400	442.0	610	152.9	381	108.4	203	64.4	203	50.8	203	54.9
18	19.500	26.50	451.0	16.50	328.0	8.50	186.0	8.50	145.0	8.50	146.0
450	495.3	673	204.6	419	148.8	216	84.4	216	65.8	216	66.2
20	21.600	29.00	588.0	18.00	413.0	9.50	246.0	9.50	200.0	9.50	202.0
500	548.6	737	266.7	457	187.3	241	111.6	241	90.7	241	91.6
24	25.800	34.00	909.0	22.00	668.0	11.00	414.0	11.00	282.0	11.00	284.0
600	655.3	864	412.3	559	303.0	279	187.8	279	127.9	279	128.8
30	32.000	41.50	2136.0	25.00	1002.0	15.00	720.0	15.00	681.0	15.00	699.0
750	762.0	1054	968.9	635	454.4	381	326.6	381	308.9	381	317.1
36	38.300	49.00	3120.0	28.00	1608.0	18.00	1152.0	18.00	975.0	18.00	1124.0
900	914.4	1245	1415.2	711	729.4	457	522.6	457	442.3	457	509.8

Grooved AWWA Ductile Iron Pipe – Fittings

Tee, True Wye, Cross, Lateral, and Cap

- NO. 20-C Tee
- NO. 33-C True Wye
- NO. 35-C Cross
- NO. 30-C 45° Lateral
- NO. 60-C Cap

For Complete Information Request Publication **23.05**

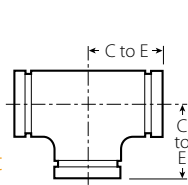

NO. 20-C

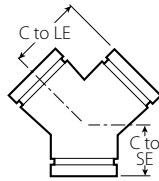

NO. 33-C

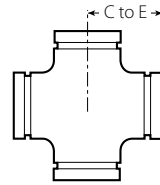

NO. 35-C

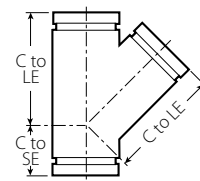

NO. 30-C



NO. 60-C

Size		No. 20-C Tee		No. 33-C True Wye			No. 35-C Cross		No. 30-C 45° Lateral			No. 60-C Cap†	
Nominal Size Inches mm	Actual Outside Dia. Inches mm	C to E Inches mm	Approx. Wgt. Each Lbs. kg	C to LE Inches mm	C to SE Inches mm	Approx. Wgt. Each Lbs. kg	C to E Inches mm	Approx. Wgt. Each Lbs. kg	C to LE Inches mm	C to SE Inches mm	Approx. Wgt. Each Lbs. kg	T Thickness Inches mm	Approx. Wgt. Each Lbs. kg
3 80	3.960 100.6	5.50 140	14.2 6.4	3.00 140	3.00 76	25.00 635	5.50 140	24.0 10.9	10.00 254	3.00 76	28.0 12.7	1.22 31	3.0 1.4
4 100	4.800 121.9	6.50 165	19.0 8.6	6.50 165	3.00 76	55.0 25.0	6.50 165	40.0 18.1	12.00 305	3.00 76	38.4 12.7	1.16 29	5.0 2.3
6 150	6.900 175.3	8.00 203	34.0 15.4	8.00 203	3.50 89	90.0 40.8	8.00 203	71.0 32.2	14.50 368	3.50 89	67.0 30.4	1.16 29	9.0 4.1
8 200	9.050 229.9	9.00 229	59.0 26.8	9.00 229	4.50 114	140.0 63.5	9.00 229	106.0 48.1	17.50 445	4.50 114	120.0 54.4	1.34 34	16.0 7.3
10 250	11.100 281.9	11.00 279	111.0 50.4	11.00 279	5.00 127	220.0 99.8	11.00 279	225.0 102.1	20.50 521	5.00 127	215.0 97.5	1.53 39	37.2 16.9
12 300	13.200 335.3	12.00 305	136.0 61.7	12.00 305	5.50 140	315.0 142.9	12.00 305	310.0 140.6	24.50 622	5.50 140	346.0 157.0	1.53 39	52.0 23.6
14 350	15.300 388.6	14.00 356	262.0 118.8	14.00 356	6.00 152	+	14.00 356	307.0 139.3	27.00 686	6.00 152	492.0 223.2	2.75* 70	55.0 25.0
16 400	17.400 442.0	15.00 381	304.0 137.9	15.00 381	6.50 165	+	15.00 381	426.0 193.2	30.00 762	6.50 165	696.0 315.7	2.75* 70	68.0 30.9
18 450	19.500 495.3	16.50 419	408.0 185.1	16.50 419	7.00 178	+	16.50 419	567.0 254.9	32.00 813	7.00 178	870.0 394.6	2.75* 70	90.0 40.8
20 500	21.600 548.6	18.00 457	552.0 250.4	18.00 457	8.00 203	+	18.00 457	717.0 325.2	35.00 889	8.00 203	1103.0 500.3	2.75* 70	110.0 50.0
24 600	25.800 655.3	22.00 559	980.0 444.5	22.00 559	9.00 229	+	22.00 559	1177.0 533.9	40.50 1029	9.00 229	1746.0 792.0	2.75* 70	165.0 74.8
30 750	32.000 762.0	25.00 635	1552.0 704.0	25.00 635	10.00 254	+	25.00 635	1366.0 619.6	49.00 1245	10.00 254	3280.0 1487.8	4.00* 102	300.0 136.1
36 900	38.300 914.4	28.00 711	2050.0 929.9	28.00 711	15.25 387	+	28.00 711	1885.0 855.0	56.00 1422	15.25 387	5020.0 2277.1	4.00* 102	536.0 243.1

* Dish caps.

+ Contact Victaulic for details.

† Caps from ½–3"/15–80 mm tap sizes.

Bullhead Tee

NO. 21-C

For Complete Information Request Publication **23.05**

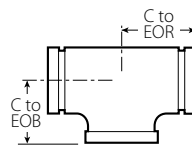

NO. 21-C

Size		Dimensions		Approx. Weight Each
Nominal Size Inches mm		C to EOR Inches mm	C to EOB Inches mm	Lbs. kg
4 100	4 100 × 6 150	+	+	47.0 21.3
6 150	6 150 × 8 200	8.00 203	8.00 203	79.0 35.8
8 200	8 200 × 10 250	11.00 279	11.00 279	164.0 74.4
10 250	10 250 × 12 300	+	+	226.0 102.5

+ Contact Victaulic for details.

Grooved AWWA Ductile Iron Pipe – Fittings

Reducing Fittings

- NO. 25-C Reducing Tee
- NO. 35-CR Reducing Cross
- NO. 30-CR 45° Reducing Lateral

For Complete Information
Request Publication **23.05**

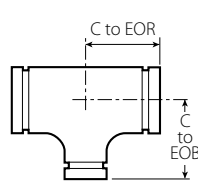

NO. 25-C

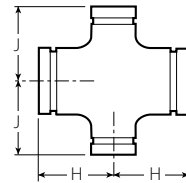

NO. 35-CR

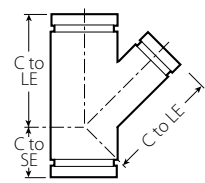

NO. 30-CR

Size		No. 25-C Reducing Tee			No. 35-CR Reducing Cross			No. 30-CR 45° Reducing Lateral					
Nominal Size Inches mm		C to EOR Inches mm	C to EOB Inches mm	Approx. Weight Each Lbs. kg	H Inches mm	J Inches mm	Approx. Weight Each Lbs. kg	C to LE Inches mm	C to SE Inches mm	Approx. Weight Each Lbs. kg			
4	3	6.50	6.50	26.4	6.50	6.50	22.0	12.00	3.00	45.0			
		165	165	12.0							305	76	20.4
6	3	8.00	8.00	30.0	8.00	8.00	46.0	14.50	3.50	74.0			
		203	203	13.6							368	89	33.6
6	4	8.00	8.00	34.0	8.00	8.00	38.0	14.50	3.50	80.0			
		203	203	15.4							368	89	36.3
8	3	9.00	9.00	+	9.00	9.00	76.0	17.50	4.50	125.0			
		229	229	78.0							445	114	56.7
		100	229	35.4							445	114	63.5
8	6	9.00	9.00	80.0	9.00	9.00	59.0	17.50	4.50	140.0			
		229	229	36.3							445	114	63.5
		150	229	36.3							445	114	63.5
10	4	11.00	11.00	120.0	11.00	11.00	120.0	20.50	5.00	204.0			
		279	279	54.4							521	127	92.5
		150	279	58.1							521	127	96.2
10	6	11.00	11.00	128.0	11.00	11.00	114.0	20.50	5.00	212.0			
		279	279	58.1							521	127	96.2
		200	279	59.0							521	127	107.1
10	8	11.00	11.00	130.0	11.00	11.00	123.0	20.50	5.00	236.0			
		279	279	59.0							521	127	107.1
		200	279	59.0							521	127	107.1
12	4	12.00	12.00	112.0	12.00	12.00	174.0	24.50	5.50	290.0			
		305	305	50.8							622	140	131.5
		150	305	81.7							622	140	137.0
		200	305	84.4							622	140	147.0
12	8	12.00	12.00	186.0	12.00	12.00	139.0	24.50	5.50	324.0			
		305	305	84.4							622	140	147.0
		250	305	192.0							622	140	356.0
		305	305	87.1							622	140	161.5
14	6	14.00	14.00	238.0	14.00	14.00	215.0	27.00	6.00	330.0			
		356	356	108.0							686	152	149.7
		200	356	241.0							686	152	346.0
		356	356	109.3							686	152	156.9
14	10	14.00	14.00	258.0	14.00	14.00	235.0	27.00	6.00	540.0			
		356	356	114.8							686	152	244.9
		250	356	267.0							686	152	625.0
		300	356	121.1							686	152	283.5
16	6	15.00	15.00	288.0	15.00	15.00	266.0	30.00	6.50	570.0			
		381	381	130.6							762	165	258.6
		200	381	315.0							762	165	585.0
		381	381	142.9							762	165	265.4
16	10	15.00	15.00	319.0	15.00	15.00	291.0	30.00	6.50	630.0			
		381	381	144.7							762	165	285.8
		250	381	330.0							762	165	650.0
		381	381	149.7							762	165	294.8
16	14	15.00	15.00	341.0	15.00	15.00	280.0	30.00	6.50	692.0			
		381	381	154.7							762	165	313.9
		350	381	341.0							762	165	692.0
		381	381	154.7							762	165	313.9
18	8	13.00	15.50	326.0	15.50	13.00	272.0	+	+	+			
		330	394	147.9							394	330	123.4
	10	13.00	15.50	332.0	15.50	13.00	277.0	32.00	7.00	765.0			
		330	394	150.6							394	330	125.6
	12	13.00	15.50	339.0	15.50	13.00	291.0	32.00	7.00	800.0			
		330	394	153.8							394	330	132.0
14	16.50	16.50	441.0	16.50	16.50	361.0	32.00	7.00	865.0				
	419	419	200.0							419	419	163.7	813
16	16.50	16.50	453.0	16.50	16.50	367.0	32.00	7.00	895.0				
400	419	419	205.5	419	419	166.5	813	178	406.0				

TABLE CONTINUED ON PG. 13-10

+ Contact Victaulic for details.

IMPORTANT NOTE: Non-standard reducing cross sizes are available. Contact Victaulic for details.



Grooved AWWA Ductile Iron Pipe – Fittings

Reducing Fittings (cont'd)

- NO. 25-C** Reducing Tee
- NO. 35-CR** Reducing Cross
- NO. 30-CR** 45° Reducing Lateral

For Complete Information
Request Publication **23.05**

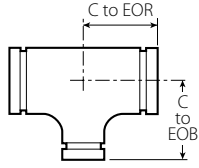

NO. 25-C

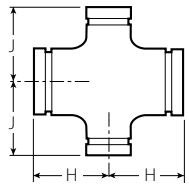

NO. 35-CR

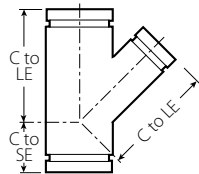

NO. 30-CR

Size	No. 25-C Reducing Tee			No. 35-CR Reducing Cross			No. 30-CR 45° Reducing Lateral			
	Nominal Size Inches mm	C to EOR Inches mm	C to EOB Inches mm	Approx. Weight Each Lbs. kg	H Inches mm	J Inches mm	Approx. Weight Each Lbs. kg	C to LE Inches mm	C to SE Inches mm	Approx. Weight Each Lbs. kg
TABLE CONTINUED FROM PG. 13-9										
20 500	6 150	14.00	17.00	+	—	—	—	—	—	—
		356	432	+	—	—	—	—	—	—
	8 200	14.00	17.00	412.0	17.00	14.00	343.0	—	—	—
		356	432	186.9	432	356	155.6	—	—	—
	10 250	14.00	17.00	419.0	17.00	14.00	343.0	+	+	+
		356	432	190.1	432	356	155.6	+	+	+
	12 300	14.00	17.00	426.0	17.00	14.00	357.0	35.00	8.00	1000.0
		356	432	193.2	432	356	161.9	889	203	453.6
14 350	14.00	17.00	443.0	17.00	14.00	327.0	35.00	8.00	1062.0	
	356	432	201.0	432	356	148.3	889	203	481.7	
16 400	18.00	18.00	571.0	18.00	18.00	458.0	35.00	8.00	1105.0	
	457	457	259.0	457	457	207.7	889	203	501.2	
18 450	18.00	18.00	584.0	18.00	18.00	469.0	35.00	8.00	1150.0	
	457	457	264.9	457	457	212.7	889	203	521.6	
24 600	6 150	15.00	19.00	+	—	—	—	—	—	—
		381	483	+	—	—	—	—	—	—
	8 200	15.00	19.00	483.0	15.00	19.00	475.0	+	+	+
		381	483	269.0	381	483	215.5	+	+	+
	10 250	15.00	19.00	593.0	15.00	19.00	450.0	40.50	9.00	1510.0
		381	483	276.7	381	483	204.1	1029	229	684.9
	12 300	15.00	19.00	610.0	15.00	19.00	450.0	40.50	9.00	1580.0
		381	483	281.2	381	483	202.3	1029	229	716.7
	14 350	22.00	22.00	918.0	22.00	22.00	782.0	40.50	9.00	1306.0
		559	559	416.4	559	559	354.7	1029	229	592.4
16 400	22.00	22.00	937.0	22.00	22.00	788.0	40.50	9.00	1705.0	
	559	559	425.0	559	559	357.4	1029	229	773.4	
30 750	6 150	18.00	23.00	+	—	—	—	—	—	—
		457	584	+	—	—	—	—	—	—
	8 200	18.00	23.00	457.0	18.00	23.00	888.0	49.00	10.00	2178.0
		457	584	269.0	457	584	402.8	1245	254	987.9
	10 250	18.00	23.00	1250.0	18.00	23.00	853.0	49.00	10.00	2208.0
		457	584	567.0	457	584	386.9	1245	254	1001.5
	12 300	18.00	23.00	1437.0	18.00	23.00	843.0	49.00	10.00	2248.0
		457	584	651.0	457	584	382.4	1245	254	1019.7
	14 350	18.00	23.00	1450.0	18.00	23.00	839.0	49.00	10.00	2294.0
		457	584	657.7	457	584	380.6	1245	254	1040.6
	16 400	18.00	23.00	1462.0	18.00	23.00	835.0	49.00	10.00	2339.0
		457	584	663.2	457	584	378.8	1245	254	1061.0
	18 450	25.00	25.00	1475.0	25.00	25.00	1304.0	49.00	10.00	2451.0
		635	635	669.1	635	635	591.5	1245	254	1111.8
36 900	8 200	20.00	26.00	+	+	+	+	+	+	+
		508	660	+	+	+	+	+	+	+
	10 250	20.00	26.00	+	+	+	+	+	+	+
		508	660	+	+	+	+	+	+	+
	12 300	20.00	26.00	+	20.00	26.00	1262.0	+	+	+
		508	660	+	508	660	572.4	+	+	+
	14 350	20.00	26.00	+	20.00	26.00	1222.0	+	15.25	+
		508	660	+	508	660	554.3	+	387	+
	16 400	20.00	26.00	+	20.00	26.00	1213.0	54.00	15.25	3493.0
		508	660	+	508	660	550.2	1372	387	1584.4
	18 450	20.00	26.00	+	20.00	26.00	1204.0	54.00	15.25	3533.0
		508	660	+	508	660	546.1	1372	387	1602.6
20 500	20.00	26.00	+	20.00	26.00	1190.0	54.00	15.25	3574.0	
	508	660	+	508	660	539.8	1372	387	1621.2	
24 600	20.00	26.00	+	20.00	26.00	1163.0	54.00	15.25	3675.0	
	508	660	+	508	660	527.5	1372	387	1667.0	
30 750	28.00	28.00	+	28.00	28.00	1865.0	56.00	15.25	3879.0	
	711	711	+	711	711	846.0	1422	387	1759.5	

+ Contact Victaulic for details.

IMPORTANT NOTES: For 30"/750mm sizes and larger contact Victaulic for details.

Non-standard reducing cross sizes are available. Contact Victaulic for details.

Grooved AWWA Ductile Iron Pipe – Fittings

Reducers and Reducing Elbows

- NO. 50-C** Concentric Reducer
- NO. 51-C** Eccentric Reducer
- NO. 10-CR** 90° Reducing Elbow
- NO. 100-CR** 90° Long Radius Reducing Elbow

For Complete Information
Request Publication **23.05**

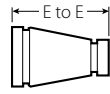

NO. 50-C

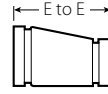

NO. 51-C

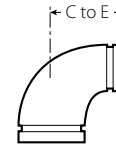

NO. 10-CR

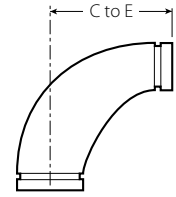

NO. 100-CR

Size	No. 50-C Concentric Reducer		No. 51-C Eccentric Reducer		No. 10-CR 90° Reducing Elbow		No. 100-CR 90° Long Radius Red. El.		
Nominal Size Inches mm	E to E Inches mm	Approx. Weight Each Lbs. kg	E to E Inches mm	Approx. Weight Each Lbs. kg	C to E Inches mm	Approx. Weight Each Lbs. kg	C to E Inches mm	Approx. Weight Each Lbs. kg	
4 100	3 80	7.00	10.0	7.00	12.0	6.50	17.0	9.00	20.0
		178	4.5	178	5.4	165	7.7	229	8.1
6 150	3 80	9.00	15.0	9.00	20.0	8.00	28.5	11.50	36.0
		229	6.8	229	9.1	203	12.9	292	16.3
	4 100	9.00	16.5	9.00	25.0	8.00	29.6	11.50	40.0
		229	7.5	229	11.3	203	13.4	292	18.1
8 200	3 80	11.00	33.0	11.00	+	—	—	—	—
		279	15.0	279	—	—	—	—	—
	4 100	11.00	28.0	11.00	35.0	9.00	46.5	14.00	60.0
		279	12.7	279	15.9	229	21.1	356	27.2
10 250	6 150	11.00	34.0	11.00	44.0	9.00	48.5	14.00	71.0
		279	15.4	279	20.0	229	22.0	356	32.2
	4 100	12.00	42.0	12.00	54.0	11.00	68.0	16.50	90.0
		305	19.1	305	24.5	279	30.8	419	40.8
12 300	6 150	12.00	46.0	12.00	60.0	11.00	77.0	16.50	106.0
		305	20.9	305	27.2	279	34.9	419	48.1
	8 200	12.00	50.0	12.00	70.0	11.00	88.0	16.50	121.0
		305	22.7	305	31.8	279	39.9	419	54.9
14 350	4 100	14.00	60.0	14.00	82.0	12.00	+	+	+
		356	27.2	356	37.2	305	—	—	—
	6 150	14.00	70.0	14.00	84.0	12.00	110.0	19.00	143.0
		356	31.8	356	38.1	305	49.9	483	64.9
	8 200	14.00	74.0	14.00	91.0	12.00	126.0	19.00	163.0
356		33.6	356	41.3	305	57.2	483	73.9	
10 250		14.00	84.0	14.00	110.0	12.00	150.0	19.00	188.0
		356	38.1	356	49.9	305	68.0	483	85.3
16 400	6 150	16.00	89.0	16.00	104.0	14.00	+	+	+
		406	40.4	406	47.2	356	—	—	—
	8 200	16.00	102.0	16.00	121.0	14.00	135.0	21.50	183.0
		406	46.3	406	54.9	356	61.2	546	83.0
	10 250	16.00	112.0	16.00	135.0	14.00	170.0	21.50	213.0
406		50.8	406	61.2	356	77.1	546	96.6	
18 450	12 300	16.00	126.0	16.00	150.0	14.00	195.0	21.50	240.0
		406	57.4	406	68.0	356	88.5	546	108.9
	14 350	18.00	11.0	18.00	140.0	—	—	+	+
		457	49.9	457	63.5	—	—	—	—
		8 200	18.00	122.0	18.00	160.0	15.00	+	24.00
		457	55.3	457	72.6	381	610	103.4	
10 250	18.00	135.0	18.00	168.0	15.00	195.0	24.00	263.0	
	457	61.2	457	76.2	381	88.5	610	119.3	
12 300	18.00	146.0	18.00	190.0	15.00	240.0	24.00	295.0	
	457	66.2	457	86.2	381	108.9	610	133.8	
	14 350	18.00	173.0	18.00	210.0	15.00	280.0	24.00	290.0
		457	78.5	457	95.3	381	127.0	610	131.5
18 450	8 200	19.00	148.0	19.00	180.0	16.50	+	—	—
		483	67.1	483	81.6	419	—	—	—
	10 250	19.00	158.0	19.00	215.0	16.50	+	26.50	+
		483	71.1	483	97.5	419	—	673	—
	12 300	19.00	173.0	19.00	215.0	16.50	305.0	26.50	336.0
		483	78.5	483	97.5	419	138.3	673	152.4
14 350	19.00	200.0	19.00	230.0	16.50	345.0	26.50	355.0	
	483	90.7	483	104.3	419	156.5	673	161.0	
16 400	19.00	220.0	19.00	275.0	16.50	360.0	26.50	386.0	
	483	100.0	483	124.7	419	163.3	673	175.1	

TABLE CONTINUED ON PG. 13-12

+ Contact Victaulic for details.

IMPORTANT NOTE:

For 30"/750 mm sizes and larger contact Victaulic for details.



Grooved AWWA Ductile Iron Pipe – Fittings

Reducers and Reducing Elbows (cont'd)

- NO. 50-C** Concentric Reducer
- NO. 51-C** Eccentric Reducer
- NO. 10-CR** 90° Reducing Elbow
- NO. 100-CR** 90° Long Radius Reducing Elbow

For Complete Information Request Publication **23.05**

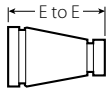

NO. 50-C

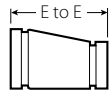

NO. 51-C

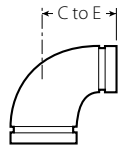

NO. 10-CR

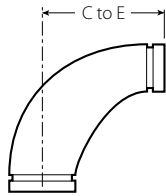

NO. 100-CR

Size		No. 50-C Concentric Reducer		No. 51-C Eccentric Reducer		No. 10-CR 90° Reducing Elbow		No. 100-CR 90° Long Radius Red. El.	
Nominal Size Inches	mm	E to E Inches	Approx. Weight Each Lbs. kg	E to E Inches	Approx. Weight Each Lbs. kg	C to E Inches	Approx. Weight Each Lbs. kg	C to E Inches	Approx. Weight Each Lbs. kg
TABLE CONTINUED FROM PG. 13-11									
20 500	8 200	20.00 508	173.0 78.5	20.00 508	+	—	—	—	—
	10 250	20.00 508	182.0 82.6	20.00 508	215.0 97.5	18.00 457	+	29.00 737	+
	12 300	20.00 508	201.0 91.2	20.00 508	250.0 113.4	18.00 457	365.0 165.6	29.00 737	+
	14 350	20.00 508	230.0 104.3	20.00 508	270.0 122.5	18.00 457	405.0 183.7	29.00 737	+
	16 400	20.00 508	251.0 113.9	20.00 508	300.0 136.1	18.00 457	440.0 199.6	29.00 737	466.0 211.4
	18 450	20.00 508	275.0 124.7	20.00 508	320.0 145.2	18.00 457	485.0 220.0	29.00 737	507.0 230.0
24 600	8 200	24.00 610	257.0 116.6	24.00 610	300.0 136.1	+	+	+	+
	10 250	24.00 610	274.0 124.3	24.00 610	300.0 136.1	+	+	+	+
	12 300	24.00 610	293.0 132.9	24.00 610	395.0 179.2	22.00 559	590.0 267.6	34.00 864	+
	14 350	24.00 610	331.0 150.1	24.00 610	425.0 192.8	22.00 559	630.0 285.8	34.00 864	+
	16 400	24.00 610	358.0 162.4	24.00 610	455.0 206.4	22.00 559	690.0 313.0	34.00 864	658.0 298.5
	18 450	24.00 610	386.0 175.1	24.00 610	465.0 210.9	22.00 559	735.0 333.4	34.00 864	+
	20 500	24.00 610	418.0 189.6	24.00 610	525.0 238.1	22.00 559	815.0 369.7	34.00 864	759.0 344.3
	30 750	+	+	+	+	+	+	—	—
30 750	10 250	+	+	+	+	+	+	—	—
	12 300	30.00 762	+	30.00 762	+	+	+	—	—
	14 350	30.00 762	+	30.00 762	+	25.00 635.0	+	—	—
	16 400	30.00 762	+	30.00 762	+	25.00 635.0	+	41.50 1054	+
	18 450	30.00 762	+	30.00 762	+	25.00 635.0	+	41.50 1054	+
	20 500	30.00 762	+	30.00 762	+	25.00 635.0	+	41.50 1054	+
	24 600	30.00 762	+	30.00 762	+	25.00 635.0	1170.0 530.7	41.50 1054	+
	36 900	+	+	+	+	+	+	—	—
	10 250	+	+	+	+	+	+	—	—
	12 300	+	+	+	+	+	+	—	—
14 350	36.00 914	+	36.00 914	+	+	+	—	—	
16 400	36.00 914	+	36.00 914	+	+	+	—	—	
18 450	36.00 914	+	36.00 914	+	+	+	—	—	
20 500	36.00 914	1280.0 580.6	36.00 914	+	+	+	49.00 1245	+	
24 600	36.00 914	1370.0 621.4	36.00 914	+	+	+	49.00 1245	+	
30 750	36.00 914	1450.0 657.7	36.00 914	+	+	+	49.00 1245	+	

+ Contact Victaulic for details.

IMPORTANT NOTE:

For 30"/750 mm sizes and larger contact Victaulic for details.

Grooved AWWA Ductile Iron Pipe – Fittings

Base Fittings

NO. 10-CB Base Elbow

NO. 20-CB Base Tee

NO. 25-CB Reducing Base Tee

NO. 100-CB Long Radius Base Tee

For Complete Information
Request Publication **23.05**

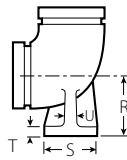

NO. 10-CB

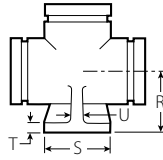

NO. 20-CB

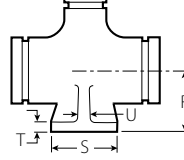

NO. 25-CB

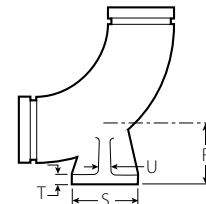

NO. 100-CB



ROUND BASE

Size		Dimensions					Approx. Weight Each			
Nominal Size Inches mm	Actual Outside Dia. Inches mm	R Inches mm	U Inches mm	T Inches mm	S Inches mm	W Inches mm	No. 10-CB Base Elbow Lbs. kg	No. 20-CB Base Tee Lbs. kg	No. 100-CB LR Base Elbow Lbs. kg	No. 25-CB Red. Base Tee Lbs. kg
3 80	3.960 100.6	4.88 124	0.50 13	0.56 14	5.00 127	3.88 99	19.0 8.6	19.0 8.6	-	+
4 100	4.800 121.9	5.50 140	0.50 13	0.62 16	6.00 152	4.75 121	23.6 10.7	26.0 11.8	-	+
6 150	6.900 175.3	7.00 178	0.62 16	0.69 18	7.00 178	5.50 140	42.0 19.1	50.0 22.7	-	+
8 200	9.050 229.9	8.38 213	0.88 22	0.94 24	9.00 229	7.50 191	75.0 34.0	92.0 41.7	-	+
10 250	11.100 281.9	9.75 248	0.88 22	0.94 24	9.00 229	7.50 191	114.0 51.7	125.0 56.7	-	+
12 300	13.200 335.3	11.25 286	1.00 25	1.00 25	11.00 279	9.50 241	152.0 69.0	183.0 83.0	-	+
14 350	15.300 388.6	12.50 318	1.00 25	1.00 25	11.00 279	9.50 241	-	-	340.0 154.2	+
16 400	17.400 442.0	13.75 349	1.00 25	1.00 25	11.00 279	9.50 241	-	-	425.0 192.8	+
18 450	19.500 495.3	15.00 381	1.12 29	1.12 29	13.50 343	11.75 299	-	-	591.0 268.1	+
20 500	21.600 548.6	16.00 406	1.12 29	1.12 29	13.50 343	11.75 299	-	-	717.0 325.2	+
24 600	25.800 655.3	18.50 470	1.12 29	1.12 29	13.50 343	11.75 299	-	-	1056.0 479.0	+

+ 90° reducing elbows are available with a base. Contact Victaulic for details.

IMPORTANT NOTES:

Bolt hole template shown for round base is the same as for the flange of the supporting pipe size, except using only four holes in all cases so placed as to straddle center lines.

The bases of these fittings are intended for support in compression and are not to be used for anchors or supports in tension or shear.

Grooved end base 90° elbows (#X-90 CDI) and base tees (#X-CDI) are available with dimensions to ANSI B16.1.

Side base fittings are available. Contact Victaulic for details.

Grooved AWWA Ductile Iron Pipe – Fittings

Flared and Outlet Fittings

NO. 10-CF 90° Flare

NO. 100-CF 90° Long Radius Flare

NO. 43-CF Straight Flare

NO. 10-CS 90° Side Outlet

NO. 20-CS Tee Side Outlet

For Complete Information
Request Publication **23.05**

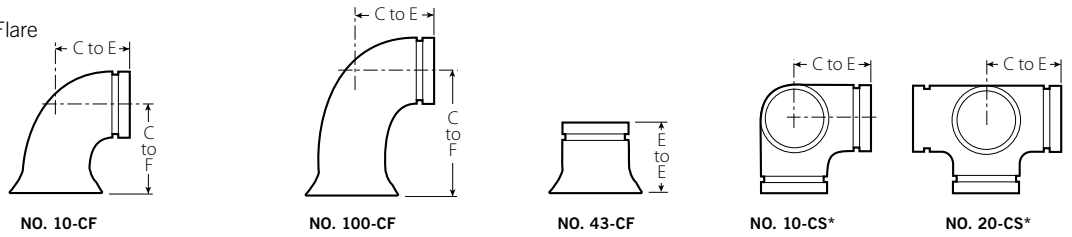

Size		No. 10-CF 90° Flare			No. 100-CF 90° Long Radius Flare			No. 43-CF Straight Flare		No. 10-CS* 90° Side Outlet		No. 20-CS* Tee Side Outlet	
Nominal Size Inches mm	Actual Outside Dia. Inches mm	C to E Inches mm	C to F Inches mm	Approx. Wgt. Each Lbs. kg	C to E Inches mm	C to F Inches mm	Approx. Wgt. Each Lbs. kg	E to E Inches mm	Approx. Wgt. Each Lbs. kg	C to E Inches mm	Approx. Wgt. Each Lbs. kg	C to E Inches mm	Approx. Wgt. Each Lbs. kg
3 80	3.960 100.6	5.50 140	9.00 229	18.0 8.2	7.75 197	11.25 286	23.0 10.4	8.00 203	13.0 5.9	5.50 140	13.0 5.9	5.50 140	28.0 12.7
4 100	4.800 121.9	6.50 165	9.50 241	35.0 15.9	9.00 229	12.50 318	42.0 19.1	8.00 203	17.0 7.7	6.50 165	30.0 13.6	6.50 165	42.0 19.1
6 150	6.900 175.3	8.00 203	11.50 292	70.0 31.8	11.50 292	15.00 381	68.0 30.9	8.00 203	23.0 10.4	8.00 203	58.0 26.3	8.00 203	85.0 38.6
8 200	9.050 229.9	9.00 229	13.50 343	120.0 54.4	14.00 356	18.50 470	118.0 53.5	10.00 254	43.0 19.5	9.00 229	90.0 40.8	9.00 229	114.0 51.7
10 250	11.100 281.9	11.00 279	16.50 419	157.0 71.2	16.50 419	22.50 572	188.0 85.3	10.00 254	58.0 26.3	11.00 279	124.0 56.3	11.00 279	219.0 99.3
12 300	13.200 335.3	12.00 305	18.50 470	190.0 86.2	19.00 483	25.50 648	275.0 124.7	12.00 305	100.0 45.4	12.00 305	170.0 77.1	12.00 305	295.0 133.8
14 350	15.300 388.6	14.00 356	21.50 546	235.0 106.6	21.50 546	29.00 737	325.0 147.4	12.00 305	90.0 40.8	14.00 356	+	+	+
16 400	17.400 442.0	15.00 381	23.00 584	300.0 136.1	24.00 610	32.00 813	435.0 197.3	16.00 406	145.0 65.8	15.00 381	+	+	+
18 450	19.500 495.3	16.50 419	25.00 635	391.0 177.4	26.50 673	35.00 889	571.0 259.0	16.00 406	205.0 93.0	16.50 419	+	+	+
20 500	21.600 548.6	18.00 457	27.00 686	496.0 225.0	29.00 737	38.00 965	731.0 331.6	18.00 457	221.0 100.3	18.00 457	+	+	+
24 600	25.800 655.3	22.00 559	32.50 826	808.0 366.5	34.00 864	44.50 1130	1642.0 744.8	18.00 457	293.0 132.9	22.00 559	+	+	+
30 750	32.000 762.0	+	+	+	+	+	+	24.00 610	567.0 257.2	+	+	+	+
36 900	38.300 914.4	+	+	+	+	+	+	24.00 610	736.0 333.9	+	+	+	+

+ Contact Victaulic for details.

* Reducing side outlet 90° Elbows, Tees, and Crosses are available. Contact Victaulic for details.

Grooved AWWA Ductile Iron Pipe – Valves

Vic-Plug Valve with AWWA Standard Ends

SERIES 365

For Complete Information Request Publication 23.06



SERIES 365 GEAR OPERATOR

Size		Dimensions – Inches/mm									Approx. Wgt. Each
Nominal Size Inches mm	Actual Outside Dia. Inches mm	A End to End	B	C	D	F	H	V	K	w/o Handle Lbs. kg	
3 80	3.960 100.6	8.00 203	4.06 103	3.75 95	4.25 108	6.40 163	4.00 102	18.50 470	2.00 51	25.0 11.3	
4 100	4.800 121.9	9.00 229	4.06 103	4.44 113	4.75 121	7.52 191	4.50 114	18.50 470	2.00 51	35.0 15.9	
6 150	6.900 175.3	10.50 267	3.20 81	5.50 140	7.50 191	10.32 262	5.25 133	18.50 470	2.00 51	70.0 31.8	

Manual Handle

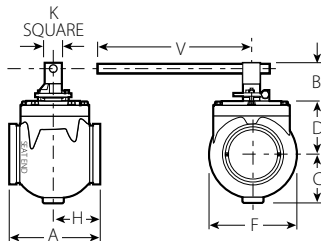

- Grooved eccentric plug valves designed to ANSI/ AWWA standards primarily for water and wastewater treatment services
- The torque required to open Vic-Plug valves will vary with pressure differential across the closed valve; using the maximum pressure differential select the correct gear operator from the chart on pg. 13-16
- A complete range of automatic operators and accessories are available with the Vic-Plug valve, please contact Victaulic with your requirements
- Eccentric plug assures bubble-tight sealing up to 175 psi/1200 kPa
- Bi-directional sealing to 25 psi/175 kPa is standard with full bi-directional sealing optionally available
- Sizes from 3 – 12"/80 – 300 mm

Valve with Gear Operator †

The torque required to open Vic-Plug valves will vary with pressure differential across the closed valve. A complete range of automatic operators and accessories are available with the Vic-Plug valve. Please contact Victaulic with your requirements.

Size		Dimensions – Inches/mm													Approx. Wgt. Each
Nominal Size Inches mm	Actual Outside Dia. Inches mm	A End to End	C	D	F	G	H	K	L	M	N.Dia	O	P	GO Series	Lbs. kg
3* 80	3.960 100.6	8.00 203	3.75 95	4.25 108	6.56 167	—	4.00 102	1.65 42	3.19 81	4.00 102	6.00 152	5.63 143	6.60 168	M12	32.0 14.5
4* 100	4.800 121.9	9.00 229	4.44 113	4.75 121	7.74 197	—	4.50 114	1.65 42	3.19 81	4.00 102	6.00 152	5.63 143	6.60 168	M12	42.0 19.1
6* 150	6.900 175.3	10.50 267	5.50 140	7.50 191	10.32 262	—	5.25 133	1.65 42	3.19 81	—	10.00 254	7.63 194	8.41 214	M12	80.0 36.3
8 200	9.050 229.9	11.50 292	6.87 175	10.80 274	12.30 312	16.38 416	5.75 145	1.65 42	3.19 81	—	18.00 457	11.63 295	10.25 261	M12	120.0 55.0
10 250	11.100 281.9	13.00 330	8.00 203	12.00 305	14.78 375	18.75 476	6.50 165	2.00 50	3.68 93	—	18.00 457	12.50 318	11.00 278	M14	185.0 84.0
12 300	13.200 335.3	14.00 356	9.50 241	13.75 349	17.00 432	21.00 533	7.00 178	2.00 50	4.15 105	—	18.00 457	13.88 352	13.00 331	M15	240.0 109.0

† Gear operators can be installed in various positions. Contact Victaulic for details.

*3, 4, 6"/80, 100, 150 mm valves do not include side support lugs.

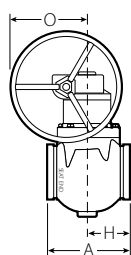

TYPICAL 3 – 6"/80 – 100 MM SIZES

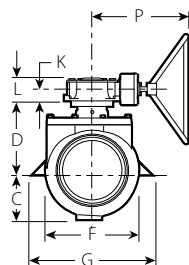

TYPICAL 8 – 12"/200 – 300 MM SIZES

Grooved AWWA Ductile Iron Pipe – Valves

Check Valve

SERIES 317

For Complete Information
Request Publication **23.09**

- Grooved end AWWA check valve
- The body conforms to AWWA C-508 standard end-to-end dimensions
- Grooved ends conform to ANSI/AWWA C-606 rigid groove specifications
- Allows easy installation with just two Victaulic couplings
- Various accessories available; lever, counter-weight, lever and spring, and adjustable air cushions
- Pressure rated up to 175 psi/1200kPa
- Sizes from 3–12"/80–300mm



SERIES 317 SPRING AND LEVER



SERIES 317 AIR CUSHION



SERIES 317 WEIGHT AND LEVER

Important Installation Considerations

Option ¹	Horizontal Orientation	Vertical Orientation
Bare	Yes	Yes
Lever with Weight	Yes	Yes ²
Lever with Spring	Yes	Yes
Lever with Adjustable Spring ³ and Air Cushion	Yes	Yes

IMPORTANT NOTES:

- 1 Valves supplied without air cushions are subject to slamming.
- 2 For proper operation in vertical orientation, lever must be rotated 90°.
- 3 All valves supplied with an air cushion will also be supplied with the adjustable spring. This is not the same spring provided with the non-air cushion options.
 - Field retrofit kits are available
 - Excessive packing nut tightness may impede rate of clapper closure
 - Valves are supplied without pressure taps and drains; Upon ordering, please specify if taps or drains are required, refer to publication 23.09 for more details

Grooved AWWA Ductile Iron Pipe – Valves

Check Valve

SERIES 317

For Complete Information
Request Publication **23.09**

Size		Dimensions																Approx. Weight Each*	Accessory Kits Approx. Weight		
Nominal Size Inches mm	Actual Outside Dia. Inches mm	A Inches mm	B Inches mm	C Inches mm	D Inches mm	E Inches mm	F Inches mm	G Inches mm	H Inches mm	J Inches mm	K Inches mm	L Inches mm	M Inches mm	N Inches mm	R Inches mm	S Inches mm	Bare Valve Lbs. kg		Spring & Lever Lbs. kg	Weight & Lever Lbs. kg	Air Cushion Lbs. kg
3 80	3.960 100.6	9.50 241	3.28 83	10.13 257	3.87 98	7.74 197	7.05 179	13.56 344	13.22 336	8.00 203	11.28 287	14.65 372	14.07 357	7.30 185	6.82 173	9.50 241	50.0 22.7	4.0 1.8	7.0 3.2	15.0 6.8	
4 100	4.800 121.9	11.50 292	4.05 103	11.38 289	4.62 117	9.24 235	7.80 198	13.93 354	13.91 353	8.75 222	10.74 273	15.03 382	14.74 374	8.05 204	7.54 192	11.74 298	70.0 31.8	4.0 1.8	7.0 3.2	15.0 6.8	
6 150	6.900 175.3	14.00 356	4.98 126	14.43 367	5.68 144	11.36 289	8.86 225	14.50 368	15.26 388	9.81 249	9.47 241	15.59 396	16.07 408	9.11 231	8.60 218	14.57 370	120.0 54.4	4.0 1.8	7.0 3.2	15.0 6.8	
8 200	9.050 229.9	19.50 495	6.12 155	18.14 461	7.15 182	14.30 363	11.34 288	20.25 514	21.37 543	12.65 321	12.74 324	21.52 547	22.21 564	11.64 296	10.37 263	17.94 456	225.0 102.1	8.0 3.6	17.0 7.7	34.0 15.4	
10 250	11.100 281.9	22.00 559	7.38 187	20.90 531	8.28 210	16.56 421	12.48 317	20.39 518	22.61 574	13.78 350	11.51 292	21.65 550	23.45 596	12.77 324	11.50 292	20.42 519	350.0 158.8	8.0 3.6	17.0 7.7	34.0 15.4	
12 300	13.200 335.3	26.00 660	8.60 218	27.04 687	9.62 244	19.24 489	13.81 351	21.00 533	24.00 610	15.12 384	10.13 257	22.27 566	24.83 631	14.11 358	12.84 326	23.05 585	460.0 217.7	8.0 3.6	17.0 7.7	34.0 15.4	

* Weights listed above are for the bare valve. Accessory kit weights are listed separately in right hand columns.

IMPORTANT NOTE:

Valve may be installed horizontally or vertically. See table on pg. 13-17 for approved usage of accessory options.

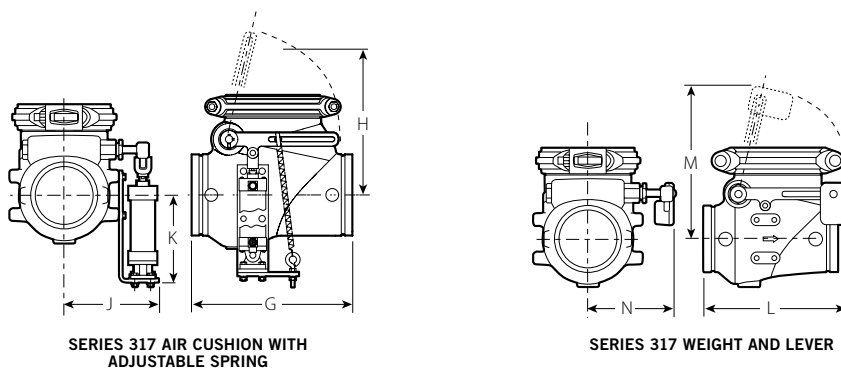
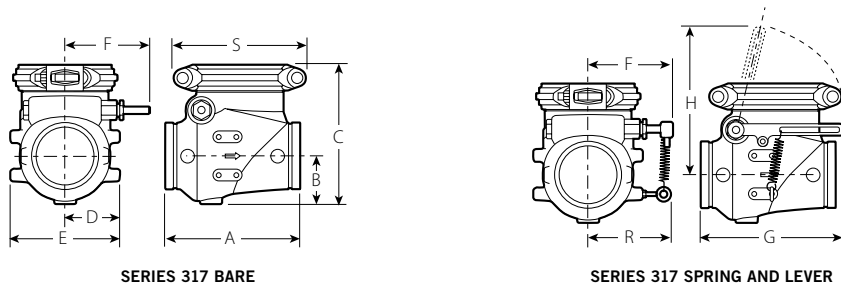

Victaulic Depend-O-Lok System

The Victaulic Depend-O-Lok joining system represents a new generation of technologically advanced couplings. Victaulic Depend-O-Lok couplings are designed, manufactured and tested to meet or exceed the performance requirements of your system.

The design of Victaulic Depend-O-Lok couplings allows for out-of-round pipe – making it easier to install than competitive joining methods. Couplings can be designed to meet almost any application or service criteria.



VICTAULIC DEPEND-O-LOK SYSTEM

Victaulic Depend-O-Lok Couplings



- Provides a reliable, economical alternative to traditional bolted sleeve-type couplings
- Available in a variety of styles to meet specific application requirements, including:

Bolted Split-Sleeve Flexible Coupling

Unrestrained, flexible bubble-tight joints (E × E)

Request Publication 60.10

Bolted Split-Sleeve Restrained Flexible Coupling

Fully restrained pipe joints without external harnessing (F × F)

Request Publication 60.11

Bolted Split-Sleeve Expansion Couplings

Pipe joints that provide for thermal expansion and contraction (F × E)

Request Publication **60.12**

FluidMaster/AirMaster



- Designed to provide fully restrained joints for air and fluid-conveying pipelines
- Shouldered couplings that are designed to operate at design pressures of the system
- Meet or exceed the performance standards set forth in AWWA C-606
- Complete line of expansion joints

Request publication **60.15**

Expansion Joint



- Offers solutions for accommodating thermal expansion and contraction of pipelines
- Products include:
 - OmniFlex Stainless Steel Bellows-Type Expansion Joints**
Can also accommodate lateral movement

Depend-O-Lok Bolted Split-Sleeve Expansion Couplings

Accommodates expansion/contraction up to 6½"/165.1 mm

PRODUCTS

- 1-1 Couplings
- 2-1 Fittings
- 3-1 Valves
- 4-1 Accessories
- 5-1 Advanced Groove System
- 6-1 Hole Cut Piping System
- 7-1 Plain End Piping System
- 8-1 Grooved System for Stainless Steel Pipe
- 9-1 Pressfit System for Stainless Steel Pipe
- 10-1 Plain End Piping System for HDPE Pipe
- 11-1 Grooved Copper
- 12-1 PermaLynx System for Copper Tube
- 13-1 Grooved AWWA Ductile Iron Pipe
- 14-1 Victaulic Depend-O-Lok System**
- 15-1 Aquamine Reusable PVC Products
- 16-1 Gaskets
- 17-1 Pipe Preparation Tools
- 18-1 Product Index
- 19-1 Piping Software

Aquamine Reusable PVC Products

Introducing the Aquamine system. Aquamine is a complete line of high impact resistant, reusable PVC pipe, fittings, valves and specialty items. Because of its superior strength and flexibility as well as other critically important features, Aquamine has become one of the leading products in its field, consistently providing the competitive edge in efficiency and productivity.

For Complete Information
Request Publication **50.01**



Aquamine Reusable PVC Products

- Synthetic rubber o-ring provides chemical resistance for a wide range of services
- High impact resistant PVC pipe and coupling provide strong piping components
- Spline assembly combines maximum strength by engaging into grooves in both the coupling and the pipe
- Thickened pipe end provides joint reinforcement and security
- Lightweight, reusable design makes Aquamine ideal for a wide variety of water services

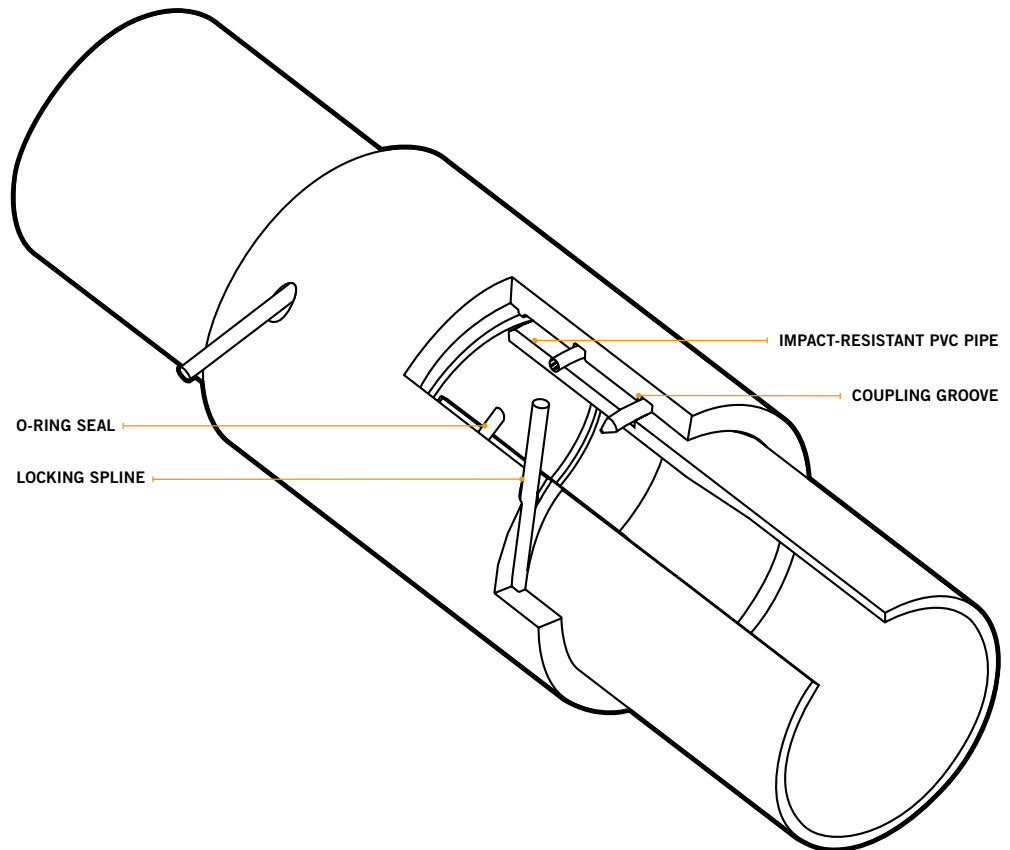

Aquamine Reusable PVC Products

Aquamine Pipe with Coupling

STYLE 2900

For Complete Information, Request Publication 50.01.

- Aquamine pipe sold in 20ft. lengths with one coupling included
- Rated up to 350psi/2413 kPa
- Available in sizes 2-12"/50-300mm

Size	Dimensions				Weight
	Nominal Size Inches/mm	SDR	Press. Rating psi/Kpa	Pipe O.D. In./mm	
2 50	17	250	2.375	0.140	0.69
		1724	60.3	3.56	0.3
	21	200	2.375	0.113	0.57
		1379	60.3	2.88	0.3
3 80	17	250	3.500	0.206	1.46
		1724	88.9	5.21	0.7
	21	200	3.500	0.167	1.19
		1379	88.9	4.24	0.5
4 100	12.4	350	4.500	0.383	2.96
		2413	114.3	9.22	1.3
	17	250	4.500	0.285	2.40
		1724	114.3	6.73	1.1
	21	200	4.500	0.173	1.60
		1379	114.3	4.39	0.7
6 150	12.4	350	6.625	0.534	6.42
		2413	168.3	13.56	2.9
	17	250	6.625	0.390	5.20
		1724	168.3	9.91	2.4
	21	200	6.625	0.316	4.26
		1379	168.3	8.03	1.9
8 200	12.4	350	8.625	0.696	11.03
		2413	219.1	17.88	5.0
	17	250	8.625	0.508	8.81
		1724	219.1	12.90	4.0
	21	200	8.625	0.410	7.21
		1379	219.1	10.41	3.3
	28	160	8.625	0.332	5.91
		1103	219.1	8.43	2.7
10 250	26	160	10.750	0.413	9.20
		1103	273.1	10.49	4.2
12 300	26	160	12.750	0.490	12.98
		1103	323.9	12.45	5.9

* Pressure rating of these items are limited by the pressure rating of the coupling.

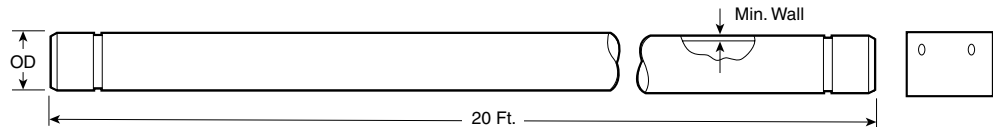

Aqua Link Coupling (ALF x ALF)

NO. 2904

For Complete Information, Request Publication 50.01.

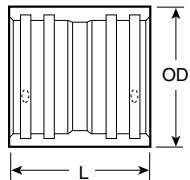

Size	Dimensions			Weight
	Nominal Size Inches/mm	Press. Rating psi/Kpa	L Inches/mm	
2	250	5.25	3.20	0.9
50	1724	133.35	81.28	0.4
3	250	7.25	4.38	1.9
80	1724	184.15	111.25	0.9
4	250	8.25	5.47	3.1
100	1724	209.55	138.94	1.4
4HP	350	8.25	6.00	5.0
100	2413	209.55	152.40	2.3
6	250	8.25	7.84	5.6
150	1724	209.55	199.14	2.5
6HP	350	8.25	8.72	10.5
150	2413	209.55	221.49	4.8
8	200	9.50	10.19	11.1
200	1379	241.30	258.83	5.0
8	250	9.50	10.19	11.1
200	1724	241.30	258.83	5.0
8HP	350	9.50	10.75	15.2
200	2413	241.30	273.05	6.9
10	160	12.00	12.44	18.0
250	1103	304.80	315.98	8.2
12	160	12.00	14.65	24.2
300	1103	304.80	372.11	11.0

Aquamine Reusable PVC Products

Aqua Link 90° Elbow (ALM x ALM)

STYLE 2910

For Complete Information, Request Publication 50.01.

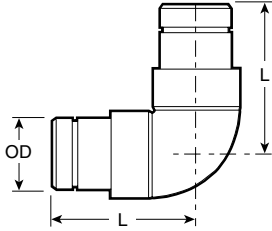

Size	Dimensions			Weight
	Nominal Size Inches mm	Press. Rating psi/Kpa	L Inches mm	
2	250	8.00	2.375	1.8
50	1724	203.20	60.33	0.8
3	250	10.88	3.500	4.6
80	1724	276.35	88.90	2.1
4	250	12.38	4.500	8.0
100	1724	314.45	114.30	3.6
6	250	15.63	6.625	19.6
150	1724	397.00	168.28	8.9
8	200	18.00	8.625	34.4
200	1379	457.20	219.08	15.6
10	160	25.10	10.750	57.2
250	1103	637.54	273.05	25.9
12	160	25.70	12.750	83.9
300	1103	652.78	323.85	38.1

Aqua Link 45° Elbow (ALM x ALM)

NO. 2912

For Complete Information, Request Publication 50.01.

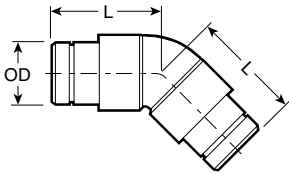

Size	Dimensions			Weight
	Nominal Size Inches mm	Press. Rating psi/Kpa	L Inches mm	
2	250	7.75	2.375	1.7
50	1724	196.85	60.33	0.8
3	250	9.75	3.500	3.9
80	1724	247.65	88.90	1.8
4	250	11.75	4.500	7.0
100	1724	298.45	114.30	3.2
6	250	13.00	6.625	16.4
150	1724	330.20	168.28	7.4
8	200	15.00	8.625	28.7
200	1379	381.00	219.08	13.0
10	160	18.30	10.750	47.4
250	1103	464.82	273.05	21.5
12	160	18.75	12.750	72.7
300	1103	476.25	323.85	33.0

Aqua Groove End Cap (ALM)

NO. 2915

For Complete Information, Request Publication 50.01.

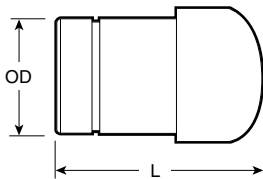

Size	Dimensions			Weight
	Nominal Size Inches mm	Press. Rating psi/Kpa	L Inches mm	
2	250	7.50	2.375	1.0
50	1724	190.5	60.33	0.5
3	250	10.00	3.500	2.2
80	1724	254.0	88.90	1.0
4	250	11.00	4.500	3.7
100	1724	279.4	114.30	1.7
6	250	14.00	6.625	8.5
150	1724	355.6	168.28	3.9
8	200	17.50	8.625	15.5
200	1379	444.5	219.08	7.0
10	160	18.50	10.750	22.4
250	1103	469.9	273.05	10.2
12	160	19.50	12.750	32.0
300	1103	495.3	323.85	14.5

Aquamine Reusable PVC Products

Aqua Groove x Flange Transition (ALM x FLG)

NO. 2916

For Complete Information,
Request Publication **50.01**.

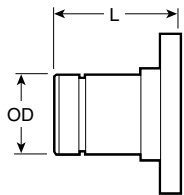

Size		Dimensions		Weight
Nominal Size Inches mm	Press. Rating psi/Kpa	L Inches mm	O.D. mm	Lbs. kg
2	150	7.25	2.375	1.5
50	1034	184,15	60,33	0,7
3	150	9.25	3.500	3.2
80	1034	234,95	88,90	1,5
4	150	10.25	4.500	5.2
100	1034	260,35	114,30	2,4
6	150	12.25	6.625	10.0
150	1034	311,15	168,28	4,5
8	150	13.88	8.625	16.0
200	1034	352,55	219,08	7,3
10	150	16.50	10.750	25.5
250	1034	419,10	273,05	11,6
12	150	16.50	12.750	37.9
300	1034	419,10	323,85	17,2

Aqua Link Tee (ALM x ALM x ALM)

NO. 2917

For Complete Information,
Request Publication **50.01**.

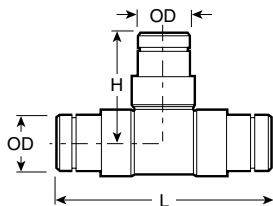

Size		Dimensions		Weight
Nominal Size Inches mm	Press. Rating psi/Kpa	L Inches mm	O.D. mm	Lbs. kg
2	250	16.50	2.375	2.6
50	1724	419,10	60,33	1,2
3	250	21.50	3.500	6.5
80	1724	546,10	88,90	2,9
4	250	24.75	4.500	10.5
100	1724	628,65	114,30	4,8
6	250	31.00	6.625	27.1
150	1724	787,40	168,28	12,3
8	200	36.25	8.625	27.8
200	1379	920,75	219,08	12,6
10	160	45.38	10.750	42.6
250	1103	1152,65	273,05	19,3
12	160	45.00	12.750	60.0
300	1103	1143,00	323,85	27,2

Aqua Link Reducing Tee (ALM x ALM x ALM)

NO. 2918

For Complete Information,
Request Publication **50.01**.

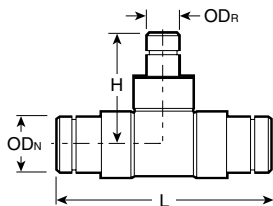

Size		Dimensions		Weight
Nominal Size Inches mm	Press. Rating psi/Kpa	L Inches mm	O.D. mm	Lbs. kg
3 X 3 X 2	250	7.50	2.375	1.0
80 X 80 X 50	1724	190.5	60.33	0.5
4 X 4 X 3	250	10.00	3.500	2.2
100 X 100 X 80	1724	254.0	88.90	1.0
X 4	250	11.00	4.500	3.7
X 100	1724	279.4	114.30	1.7
6 X 6 X 6	250	14.00	6.625	8.5
150 X 150 X 150	1724	355.6	168.28	3.9
X 8	200	17.50	8.625	15.5
X 200	1379	444.5	219.08	7.0
X 10	160	18.50	10.750	22.4
X 250	1103	469.9	273.05	10.2
8 X 8 X 12	160	19.50	12.750	32.0
200 X 200 X 300	1103	495.3	323.85	14.5
X 12	160	19.50	12.750	32.0
X 300	1103	495.3	323.85	14.5

Aquamine Reusable PVC Products

Aquamine Formed Outlet Fitting

NOS. 2937, 2938 AND 2939

For Complete Information,
Request Publication **50.01**.

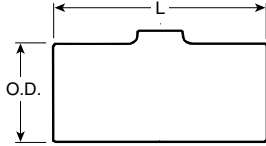

Size			Maximum Working Pressure – PSI/kPa		
Nominal Size Inches mm	L Inches mm	O.D. Inches mm	Style 2937	Style 2938	Style 2939
			1" NPT Tap	1½" NPT	2" NPT Tap
2	7.25	2.375	250	–	–
50	184,15	60,33	1725	–	–
3	9.25	3.500	250	250	–
80	234,95	88,90	1725	1725	–
4	10.25	4.500	250	250	250
100	260,35	114,30	1725	1725	1725
12	16.50	12.750	250	250	250
300	419,10	323,85	1725	1725	1725

NOTE: The pressure ratings noted above are based upon the capability of the female threaded socket. If a plastic threaded pipe nipple is used, the rating will be based upon values cited in ASTM-D1785 for Schedule 80 threaded pipe nipples.

Aquamine® Butterfly Valve

For Complete Information,
Request Publication **50.01**.

Size		Dimensions					Weight
Nominal Size Inches mm	Actual Size	End to End A	Overall Height B	C	D	E	Lbs. kg
2	2.375	7.20	5.47	1.88	4.06	3.59	3.3
50	60.3	183	139	48	103	91	1.5
3	3.500	10.61	7.12	2.76	5.63	4.37	6.0
80	88.9	269	181	70	143	111	2.7
4	4.500	12.00	10.15	3.50	7.00	6.65	14.0
100	114.3	305	258	89	178	169	6.4
6	6.625	12.50	12.65	4.50	9.50	8.65	28.0
150	168.3	318	321	114	241	220	12.7

- Rated for 250psi/1735 kPa to provide reliable, leak-free, dead-end service
- Available in sizes 2-6"/50-150mm
- Valve consists of PVC body, external ductile iron upper and lower housings, Grade "T" nitrile coated disc, bronze upper and lower bushings and two-position handle.

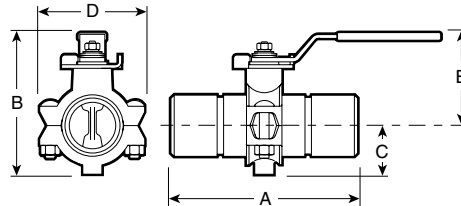

Aquamine Reusable PVC Products

Aquamine Plain End Pipe Coupling

STYLE 2970

For Complete Information, Request Publication 50.01.

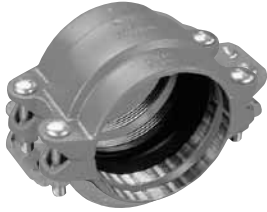

- Requires no pipe preparation, solvent or cure time
- Rugged ductile iron with patented, specially formed integral gripping teeth which engage into the pipe to secure it as the bolts are tightened metal-to-metal
- Available in sizes 2-8"/50-200mm

Size		Dimensions Inches/millimeters			Bolt/Nut No. - Size Inches	Weight
Nominal Size Inches mm	Press. Rating psi/Kpa	X	Y	Z		
2 50	2.375 60.3	3.64 92	5.94 151	3.62 92	2 - 1/2 X 2 1/2	3.5 1.6
3 80	3.500 88.9	4.58 116	6.95 177	4.56 116	4 - 1/2 X 2 3/4	7.7 3.5
4 100	4.500 114.3	5.88 149	8.09 205	5.78 147	4 - 1/2 X 2 3/4	11.6 5.3
6 150	6.625 168.3	8.00 203	10.84 275	5.88 149	4 - 5/8 X 3 1/4	16.4 7.4
8 200	8.625 219.1	10.19 259	13.22 336	6.00 152	4 - 5/8 X 3 1/4	24.9 11.3

*Working pressure and End Load are total, from all internal and external loads, based on proper coupling assembly with bolts pads metal-to-metal, on Aquamine PVC pipe. Couplings are designed to be used with plain end pipe. Metric thread size bolts (plated) are available (color coded) for all coupling sizes upon request. Contact Aquamine for details. WARNING: Piping systems must always be depressurized and drained before attempting disassembly and removal of any Aquamine piping products.

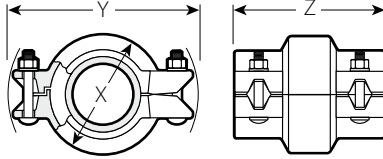

Aquamine Plain-End PVC to Grooved Transition Coupling

STYLE 2972

For Complete Information, Request Publication 50.01.



- Provides bolted, mechanical assembly for plain-end steel pipes, valves and fittings
- Join shorter sections of PVC pipe without having to use special adaptors
- Available in sizes 2-8"/50-200mm

Size		Dimensions Inches/millimeters			Bolt Data	
Nominal Size Inches mm	Actual Outside Diameter Inches mm	X	Y	Z	Quantity	Size Inches
2 50	2.375 60.3	3.31 84	5.22 133	2.78 71	2	3/8 X 2
3 80	3.500 88.9	4.38 111	6.99 178	3.20 81	4	1/2 X 2 3/4
4 100	4.500 114.3	5.68 144	8.25 210	3.90 99	4	1/2 X 2 3/4
6 150	6.625 168.3	7.84 199	11.25 286	4.00 102	4	5/8 X 3Zv
8 200	8.625 219.1	10.18 259	13.96 355	4.16 106	4	5/8 X 3 1/2

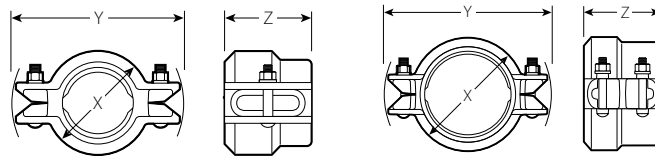

Aquamine Reusable PVC Products

Aquamine Plain-End PVC to HDPE Transition Coupling

STYLE 2971

For Complete Information, Request Publication **50.01**.

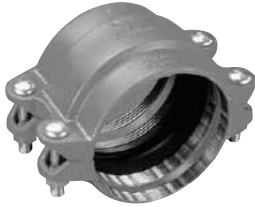

- No solvent or cure times
- Provides bolted, mechanical assembly of plain-end PVC pipe to plain-end HDPE pipe without special adaptors.
- Available in sizes 2-8"/50-200mm

Size		Dimensions Inches/millimeters			Bolt/Nut No. - Size Inches	Weight Lbs. kg
Nominal Size Inches mm	Press. Rating psi/Kpa	X	Y	Z		
2 50	2.375 60,3	3.64 92	5.94 151	3.62 92	2 - 1/2 X 2 1/2	3.5 1,6
3 80	3.500 88,9	4.58 116	6.95 177	4.56 116	4 - 1/2 X 2 3/4	7.7 3,5
4 100	4.500 114,3	5.88 149	8.09 205	5.78 147	4 - 1/2 X 2 3/4	11.6 5,3
6 150	6.625 168,3	8.00 203	10.84 275	5.88 149	4 - 5/8 X 3Zv	16.4 7,4
8 200	8.625 219,1	10.19 259	13.22 336	6.00 152	4 - 5/8 X 3Zv	24.9 11,3

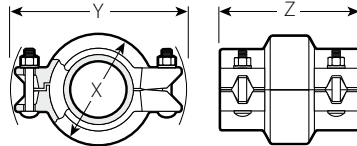

(2"/50 mm size has one bolt per side.)

Gaskets

Victaulic gaskets are designed to provide life-of-the-system service in a wide variety of applications. Gasket materials are available to meet most piping applications. For a list of service recommendations by gasket type see pg. 16-5.

For Complete Information request publication **05.01**.



Gasket Styles

ILLUSTRATIONS EXAGGERATED FOR CLARITY

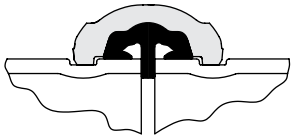

Installation-Ready

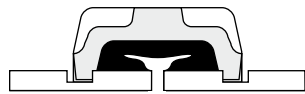

Standard

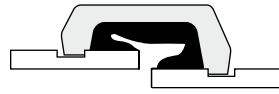

Reducing

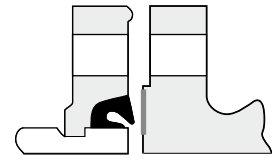

Vic-Flange

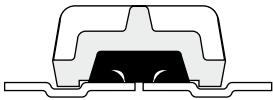

FlushSeal

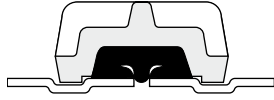

Grooved Copper Tubing with FlushSeal Gasket

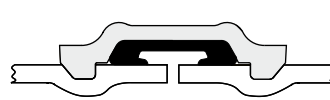

Advanced Groove System (AGS)

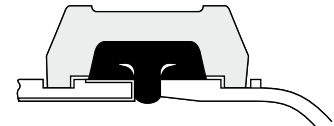

EndSeal

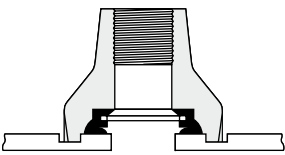

Outlet

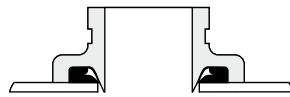

Mechanical-T

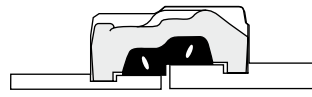

IPS to AWWA Transition

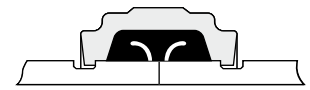

AWWA FlushSeal



Plain End



Plain End Piping System for HDPE Pipe



Pressfit Piping System for Stainless Steel

Gaskets

Gasket Materials

When Victaulic couplings were first developed, natural rubber compounds were used. As elastomer technology advanced, superior gasket materials became available and were added to the Victaulic line. This allows Victaulic to presently offer a variety of synthetic rubber gaskets to provide the option of selecting Victaulic products for the widest variety of applications. For most water applications the Victaulic Grade “E” EPDM (ethylene propylene diene monomer) gasket compound is recommended. Victaulic Grade “E” material has premium performance properties with respect to aging and resistance to heat and hot water. Heat aging tests at +250°F/+121°C conducted on this material show essentially no change in physical properties. This situation is further enhanced when this rubber is subjected to an essentially non-oxidative environment such as a gasket in a water piping system. For example, aging tests in a nonoxidative atmosphere show essentially no change in physical properties of this material even when tested at temperatures up to +350°F/+177°C.

Since water has no deteriorating effect on the elastomer, temperature is the only limiting factor to be considered in determining the life expectancy of the elastomer in water service. The superior performance of the Grade “E” elastomer permits its use for hot water service up to +230°F/+110°C. The Grade “E” gasket is superior to previous gasket materials by all performance barometers, including high and low temperature limits, tensile strength, chemical resistance and shelf life.

Gasket/O-ring Data

To assure the maximum life for the service intended, proper gasket selection and specification in ordering is essential. Many factors must be considered in determining the optimum gasket/o-ring for a specific service. The foremost consideration is temperature, along with concentration of product, duration of service and continuity of service. Temperatures beyond the recommended limits have a degrading effect on the polymer. Therefore, there is a direct relationship between temperature, continuity of service and gasket life.

Services listed are General Service Recommendations only. It should be noted that there are services for which these gaskets/o-rings are not recommended. Reference should always be made to the latest Victaulic Gasket Selection Guide (publication 05.01) for specific service recommendations and for a listing of services which are not recommended.

Gasket recommendations apply only to Victaulic gaskets and o-rings. Recommendations for a particular service do not necessarily imply compatibility of the coupling housing, related fittings or other components for the same service.

Victaulic gaskets are clearly marked as part of the mold with the gasket size, style and compound for easy identification.

PRODUCTS

- 1-1 Couplings
- 2-1 Fittings
- 3-1 Valves
- 4-1 Accessories
- 5-1 Advanced Groove System
- 6-1 Hole Cut Piping System
- 7-1 Plain End Piping System
- 8-1 Grooved System for Stainless Steel Pipe
- 9-1 Pressfit System for Stainless Steel Pipe
- 10-1 Plain End Piping System for HDPE Pipe
- 11-1 Grooved Copper
- 12-1 PermaLynx System for Copper Tube
- 13-1 Grooved AWWA Ductile Iron Pipe
- 14-1 Victaulic Depend-O-Lok® System
- 15-1 Aquamine Reusable PVC Products

16-1 Gaskets

- 17-1 Pipe Preparation Tools
- 18-1 Product Index
- 19-1 Piping Software

Gaskets

Gasket Performance



UNIQUE C-SHAPED GASKET FORMS A TRIPLE SEAL

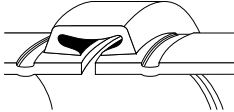

SEALS BETWEEN THE PIPE ENDS AND THE GROOVE

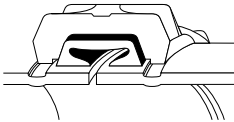

SURROUNDED, REINFORCED AND SLIGHTLY COMPRESSED BY THE HOUSING



SEAL IS ENHANCED BY PRESSURE OR VACUUM IN THE LINE

The sealing efficiency of Victaulic gaskets is such that the gasket forms an initial seal as it is stretched over the pipe ends. Upon placement of the housing around the gasket and into the grooves, the gasket is positioned. As the housing segments are tightened, the resilient elastomeric gasket conforms to the internal cavity of the housing and is further compressed, enhancing the gasket's seal against the pipe. The Victaulic gasket is pressure responsive.

The combination of these characteristics creates a permanent, leak-tight triple seal on a variety of piping materials including carbon steel, ductile iron, stainless steel, aluminum, PVC, cast iron and copper. Line pressure serves to strengthen the seal through the combination of normal gasket resilience, housing reinforcement and the action of pressure downward on the lips.

Vacuum Service – The Victaulic gasket design seals equally well under pressure or vacuum. Vacuum creates a pressure differential between the inside and outside of the piping system. The resulting increased force from the external pressure has the same seal enhancement effect as internal pressure. For continuous vacuum service greater than ten inches of mercury, we recommend the use of molded Victaulic FlushSeal gaskets or Victaulic standard gaskets with a metal ring liner, both available from your Victaulic distributor. The FlushSeal feature and the metal liner both prevent distortion of the gasket due to the pulling action of a high vacuum at the center of the gasket. Either molded FlushSeal gaskets or gaskets with metal liners are recommended on strong vacuums and are suitable for applications wherein vacuum conditions are anticipated to a maximum value of 29.9 of mercury.

ANSI/NSF 61 Standard – ANSI/NSF 61 is a National Standard that was developed to establish minimum requirements for the control of potential adverse human health effects from products which contact drinking water. Its primary focus is on contaminants or impurities which may be imparted indirectly to drinking water. Materials that do not come in direct contact with the potable water do not require evaluation. The classification categories for pipe and related products and joining and sealing materials, as established by ANSI/NSF 61 are “cold”, which is limited to +86°F/+30°C maximum and “hot” which is limited to +180°F/+82°C maximum. These categories were established by the maximum ambient distribution temperature of unheated water for “cold” and a temperature well in excess of a scalding temperature for “hot” domestic water. The following list represents the current classifications on our products:

EPDM “E” Gaskets: UL classified in accordance with ANSI/NSF 61 for cold +86°F/+30°C and hot +180°F/+82°C potable water service.

Halogenated Butyl “M” Gaskets: UL classified in accordance with ANSI/NSF 61 for cold +86°F/+30°C potable water service.

PPS Coating: The PPS (Polyphenylene Sulfide blend) coating applied to our Vic-300 MasterSeal and Style W761 AGS butterfly valves is UL classified in accordance with ANSI/NSF 61 for cold +180°F/+30°C and hot +180°F/+82°C potable water service.

Gaskets

Gasket Performance

Vic-Press 304 and Vic-Press 316 Couplings and Fittings:

UL classified in accordance with ANSI/NSF 61 for cold +86°F/+30°C and hot +180°F/+82°C potable water service with “E”, “T” or “O” o-rings.

Vic-Press 304 and Vic-Press 316 Pipe:

UL classified in accordance with ANSI/NSF 61 for cold +86°F/+30°C and hot +180°F/+82°C potable water service. In addition to the above, the standard black asphalt coating used on our cement lined AWWA size fittings is NSF 61 Listed. As the coating is the only material that comes in contact with the water, NSF 61 compliant coatings are commercially available and may be applied to our products.

For more details about Victaulic gasket construction and testing, request publication 05.01.

Gasket Lubricant



Thorough lubrication of the gasket exterior including the lips and/or pipe ends and housing interiors, is essential to prevent pinching the gasket. Lubrication assists proper gasket installation. Use Victaulic Lubricant for installation. Other compatible material, such as silicone and others may be used on Grades “E” or “L” gaskets. Lubricant is available in 4 ½ ounce tubes. Victaulic Lubricant is also available in 32 ounce containers.

Important Note: Victaulic Lubricant is **not** recommended for use with high-density polyethylene (HDPE) pipe.

ALWAYS USE LUBRICANT FOR PROPER COUPLING ASSEMBLY.

Size Nominal Size Inches mm	Number of Gaskets	
	Per Tube	Per Quart
2 50	55	400
3 80	36	270
4 100	26	200
6 150	17	125
8 200	13	100
10 250	11	80
12 300	8	60
14 350	7	50
16 400	6	45
18 450	5	35
20 500	4	30
24 600	3	20

Gaskets

Gasket Selection Guide

GASKETS

Standard Gaskets

IPS

⚠ WARNING

To assure maximum life for the service intended, proper gasket selection and specification in ordering is essential. Failure to select the proper rubber compound may result in personal injury or property damage, improper installation, joint leakage or joint failure.

Grade	Temperature Range	Compound	Color Code	General Service Recommendations *
E	-30°F to 230°F -34° C to +110° C	EPDM	Green Stripe	Recommended for hot water service within the specified temperature range plus a variety of dilute acids, oil-free air and many chemical services. UL classified in accordance with ANSI/NSF 61 for cold +86°F/+30°C and hot +180°F/+82°C potable water service. NOT RECOMMENDED FOR PETROLEUM SERVICES.
EHP[@]	-30°F to +250°F -34°C to +120°C	EPDM	Red Stripe	Recommended for hot water service within the specified temperature range. UL classified in accordance with ANSI/NSF 61 for cold +86°F/+30°C and hot +180°F/+82°C potable water service. NOT RECOMMENDED FOR PETROLEUM SERVICES.
T	-20°F to +180°F -29° C to +82° C	Nitrile	Orange Stripe	Recommended for petroleum products, hydrocarbons, air with oil vapors, vegetable and mineral oils within the specified temperature range; not recommended for hot dry air over +140°F/+60°C and water over +150°F/+66°C. NOT RECOMMENDED FOR HOT WATER SERVICES.
E[†] (Type A)	Ambient	EPDM	Violet Stripe	Applicable for wet and dry (oil-free air) sprinkler services only. For dry services, Victaulic continues to recommend the use of FlushSeal [®] gaskets. NOT RECOMMENDED FOR HOT WATER SERVICES.

† Vic-Plus pre-lubricated gasket.

* For specific chemical and temperature compatibility, refer to the Gasket Selection and Chemical Services sections. The information shown defines general ranges for all compatible fluids.

@ The Grade EHP gasket is only available on QuickVic couplings.

Special Gaskets

IPS

Grade	Temperature Range	Compound	Color Code	General Service Recommendations *
M2	-40°F to +160°F -40°C to +71°C	Epichlorohydrin	White Stripe	Specially compounded to provide superior service for common aromatic fuels at low temperatures. Also suitable for certain ambient temperature water services.
V	-30°F to +180°F -34°C to +82°C	Neoprene	Yellow Stripe	Recommended for hot lubricating oils and certain chemicals. Good oxidation resistance. Will not support combustion.
O	+20°F to +300°F -7°C to +149°C	Fluoroelastomer	Blue Stripe	Recommended for many oxidizing acids, petroleum oils, halogenated hydrocarbons, lubricants, hydraulic fluids, organic liquids and air with hydrocarbons to +300°F/+149°C. NOT RECOMMENDED FOR HOT WATER SERVICES.
L	-30°F to +350°F -34°C to +177°C	Silicone	Red Gasket	Recommended for dry heat, air without hydrocarbons to +350°F/+177°C and certain chemical services.
A	+20°F to +180°F -7°C to +82°C	White Nitrile	White Gasket	No carbon black content. May be used for food. Meets FDA requirements. Conforms to CFR Title 21 Part 177.2600. Not recommended for hot water services over +150°F/+66°C or for hot, dry air over +140°F/+60°C. NOT RECOMMENDED FOR HOT WATER SERVICES.
T EndSeal	-20°F to +150°F -29°C to +66°C	Nitrile	No External Identification	Specially compounded with excellent oil resistance and a high modulus for resistance to extrusion. Temperature range -20°F/-29°C to +150°F/+66°C. Recommended for petroleum products, air with oil vapors, vegetable and mineral oils within the specified temperature range. Not recommended for hot water services over +150°F/+66°C or for hot, dry air over +140°F/+60°C. For maximum gasket life under pressure extremes, temperature should be limited to +120°F/+49°C.
EG	-30°F to +230°F -34°C to +110°C	EPDM	Double Green Stripes	Recommended for hot water service within the specified temperature range plus a variety of dilute acids, oil-free air and many chemical services. DVGW, KTW, ÖVGW, and SVGW approved for W534, EN681-1 Type WA cold potable water service up to +122°F/+50°C. NOT RECOMMENDED FOR PETROLEUM SERVICES
EF	-30°F to +104°F -34°C to +40°C	EPDM	Green "X"	Recommended for potable water service within the specified temperature range plus a variety of dilute acids, oil-free air and many chemical services. French ACS (Crecep) approved for EN681-1 Type WA cold potable water service. NOT RECOMMENDED FOR PETROLEUM SERVICES
EW	-30°F to +203°F -34°C to +110°C	EPDM	Green "W"	Recommended for hot water service within the specified temperature range plus a variety of dilute acids, oil-free air and many chemical services. WRAS- approved material to BS 6920 for cold and hot potable water service up to +149°F /+65°C NOT RECOMMENDED FOR PETROLEUM SERVICES

Gaskets

AWWA and Transition Couplings

Grade	Temperature Range	Compound	Color Code	General Service Recommendations *
S	-20°F to +180°F -29°C to +82°C	Nitrile	Red Stripe	Specially compounded to conform to ductile pipe surfaces. Recommended for petroleum products, air with oil vapors, vegetable and mineral oils within the specified temperature range; except hot dry air over +140°F/+60°C and water over +150°F/+66°C. NOT RECOMMENDED FOR HOT WATER SERVICES.
M	-20°F to +200°F -29°C to +93°C	Halogenated Butyl	Brown Stripe	Recommended for water service within the specified temperature range plus a variety of dilute acids, oil-free air and many chemical services. Readily conforms to ductile pipe surfaces. UL classified in accordance with ANSI/NSF 61 for cold +86°F /+30°C potable water service. NOT RECOMMENDED FOR PETROLEUM SERVICES.

FOR SERVICES NOT LISTED CONTACT VICTAULIC FOR RECOMMENDATIONS.

* Gasket recommendations apply only to Victaulic gaskets. Recommendation for a particular service does not necessarily imply compatibility of the coupling housing, related fittings or other components for the same service. These recommendations do not apply to rubber lined valves.

Gasket Selection

Chemical compositions are listed in alphabetical order. Unless otherwise noted, temperatures are ambient. For chemicals or combinations not listed contact Victaulic for recommendations. **DO NOT ASSUME THAT A SERVICE SIMILAR TO THE ONE LISTED CAN BE ACCOMMODATED WITH THE SAME GASKET.**

The data and recommendations presented are based upon the best information available resulting from our field experience and laboratory testing by our own Engineering Department. In addition, we have incorporated the recommendations supplied by prime producers of basic copolymer materials and information furnished by leading molders of rubber products.

The information presented in this guide is general in scope and should be used only with this full knowledge and understanding. In unusual, critical or severe services, full information should be referred to Victaulic.

Where possible, materials should be subjected to simulated service conditions to determine their suitability for the service intended. Furthermore, it should not be concluded that, in instances where a gasket is not affected by several substances used alone, their combination will have no reaction on the gasket. Caution should be exercised with explosive, inflammable or toxic fluids. All gasket recommendations are based on pressure and temperature limitations published by Victaulic. Borderline services always should be verified by Victaulic.

Where two gaskets are shown under Gasket Grade, both are acceptable under normal conditions for the service listed.

Rating Code Key	
G	Good
C	Conditional (Submit analysis of materials to Victaulic for positive recommendations)
NR	Not Recommended (See pg. 16-8 for complete listing)

FOR SERVICES NOT LISTED CONTACT VICTAULIC FOR RECOMMENDATIONS.

Gasket recommendations apply only to Victaulic gaskets. Recommendation for a particular service does not necessarily imply compatibility of the coupling housing, related fittings or other components for the same service. These recommendations do not apply to rubber lined valves.

Gaskets

Chemical Services

GASKETS

Chemical Composition	Rating Code	Gasket Grade
ASTM #3 Oil	G	T
Acetaldehyde	G	E/EHP
Acetamide	G	T
Acetic Acid up to 10% 100°F/38°C	G	E/EHP
Acetic Acid up to 10-50% 100°F/38°C	G	L
Acetic Acid, Glacial 100°F/38°C	G	L
Acetic Anhydride	G	E/EHP
Acetone	G	E/EHP
Acetonitrile	G	T
Acetophenone	G	E/EHP
Acetylene	C	E/T/EHP
Acrylic Resin	G	V
Acrylonitrile	NR	—
Adipic Acid	G	T
Alkalis	G	E/EHP
Allyl Alcohol to 96%	G	E/EHP
Allyl Chloride	NR	—
Alum Sulfuric Acid	C	O
Alums	G	E/T/EHP
Aluminum Chloride	G	E/T/EHP
Aluminum Fluoride	G	E/T/EHP
Aluminum Hydroxide	G	E/EHP
Aluminum Nitrate	G	V/E/T/EHP
Aluminum Oxychloride	C	T
Aluminum Phosphate	G	E/EHP
Aluminum Salts	G	E/EHP
Aluminum Sulfate	G	E/T/EHP
Ammonia, Anhydrous (Pure Ammonia)	NR	—
Ammonia, Aqueous (40% Max)	G	E/EHP
Ammonium Alum	G	V
Ammonium Bifluoride	G	T
Ammonium Carbonate	G	E/EHP
Ammonium Chloride	G	T
Ammonium Fluoride	G	E/EHP
Ammonium Hydroxide	G	E/EHP
Ammonium Metaphosphate	G	E/EHP
Ammonium Nitrate	G	T
Ammonium Nitrite	G	E/EHP
Ammonium Persulfate, to 10%	G	E/EHP
Ammonium Phosphate	G	T
Ammonium Sulfamate	G	T
Ammonium Sulfate	G	E/T/EHP
Ammonium Sulfide	G	E/EHP
Ammonium Thiocyanate	G	E/EHP
Amyl Acetate	G	E/EHP
Amyl Acetate	G	E/EHP
Amyl Alcohol	G	E/EHP
Amyl Borate	G	V
Amyl Chloride	NR	—
Amyl Chloronaphthalene	C	T
Anderol	G	O
Antraquinone	NR	—
Antraquinone Sulfonic Acid	NR	—
Aniline	G	E/EHP
Aniline Dyes	C	E/EHP
Aniline Hydrochloride	C	E/EHP
Aniline Oil	G	E/EHP
Animal Fats	G	A
Antimony Chloride	G	E/EHP
Antimony Trichloride	G	E/EHP
Argon Gas	G	E/O
Aroclor(s)	G	O
Arsenic Acid, to 75%	G	T
Arylsulfonic Acid	NR	—
Barium Carbonate	G	E/EHP
Barium Chloride	G	E/T/EHP
Barium Hydroxide	G	E/T/EHP
Barium Nitrate	G	V
Barium Sulfide	G	T
Beer	G	A
Beet Sugar Liquors	G	A
Benzaldehyde	C	E/EHP
Benzene	G	O
Benzene Sulfonic (Aromatic Acid)	C	V
Benzene (see Petroleum Ether)	G	O
Benzoic Acid	G	E/EHP
Benzol	G	O

Chemical Composition	Rating Code	Gasket Grade
Benzyl Alcohol	G	E/EHP
Benzyl Benzoate	G	E/EHP
Black Sulfate Liquor	G	T
Blast Furnace Gas	C	T
Bleach, 12% Active Cl ²	C	E/EHP
Borax	G	E/EHP
Bordeaux Mixture	G	E/EHP
Boric Acid	G	E/T/EHP
Bromine	G	O
Bromine Water	G	V
Butadiene	C	V
Butane Gas	C	T
Butanol (see Butyl Alcohol)	G	E/T/EHP
Butter	G	A
Butyl Acetate	C	E/EHP
Butyl Acetyl Ricinoleate	G	E/EHP
Butyl Alcohol	G	E/T/EHP
Butyl "Cellosolve Adipate"	G	E/T/EHP
Butyl Phenol	C	E/EHP
Butyl Stearate	G	T
Butylene	G	T
Butylene Glycol	G	E/EHP
Butyne Diol	NR	—
Butyraldehyde	C	V
Cadmium Cyanide	C	V
Calcium Acetate	C	T
Calcium Bisulphate	G	T
Calcium Bisulphide	G	T
Calcium Bisulphite	G	T
Calcium Chloride	G	E/T/EHP
Calcium Fluorophosphate	C	V
Calcium Hydroxide (Lime)	G	E/T/EHP
Calcium Hypochlorite	G	E/EHP
Calcium Hypochloride	G	E/EHP
Calcium Nitrate	G	V/E/T/EHP
Calcium Sulfate	G	E/T/EHP
Calcium Sulfide	G	E/EHP
Caliche Liquors	G	T
Cane Sugar Liquors	G	A
Carbitol	G	E/T/EHP
Carbonic Acid, Phenol	G	O
Carbon Bisulphide	C	O
Carbon Dioxide, Dry	G	E/T/EHP
Carbon Dioxide, Wet	G	E/T/EHP
Carbon Disulphide	G	O
Carbon Monoxide	G	E/EHP
Carbon Tetrachloride	G	O
Castor Oil	G	A
Caustic Potash	G	E/EHP
Cellosolve Acetate	G	E/EHP
Cellosolve (Alcohol Ether)	G	E/EHP
Cellulose Acetate	G	E/EHP
Cellulose 220 (Tri-Aryl-Phosphate)	G	E/EHP
Cellulose Hydraulic Fluids	G	E/EHP
China Wood Oil, Tung Oil	G	T
Chloralhydrate	NR	—
Chloric Acid to 20%	C	E/EHP
Chlorine, Dry	C	O
Chlorine, Water 4000 PPM (max.)	C	E/EHP
Chlorinated Paraffin (Chlorococane)	G	T
Chloroacetic Acid	G	E/EHP
Chloroacetone	G	E/EHP
Chlorobenzene	C	O
Chlorobromomethane	NR	—
Chloroform	G	O
Chlorosulphonic Acid	NR	—
Chrome Alum	G	T
Chrome Plating Solutions	G	O
Chromic Acid, to 25%	G	O
Citric Acid	G	E/EHP
Cocoa Nut Oil	G	A
Cod Liver Oil	G	A
Coke Oven Gas	G	T/O
Copper Chloride	G	T
Copper Cyanide	G	T
Copper Fluoride	G	E/EHP
Copper Nitrate	G	E/T/EHP
Copper Sulfate	G	E/T/EHP
Corn Oil	G	A

Chemical Composition	Rating Code	Gasket Grade
Cotton Seed Oil	G	A
Creosol, Cresylic Acid	G	O
Creosote, Coal Tar	G	O
Creosote, Wood	G	O
Cupric Fluoride	G	T
Cupric Sulfate	G	T
Cyclohexane (Alicyclic Hydrocarbon)	G	O
Cyclohexanol	G	V
Cyclohexanone	C	E/EHP
Deionized Water	G	E/EHP
Dextrin	G	T
Diacetone Alcohol	G	V
Dibutyl Phthalate	G	E/EHP
Dichloro Difloro Methane	G	T
Dicyclohexylamine	C	T
Diesel Oil	G	T
Diethyl Ether	C	T
Diethyl Sebacate	G	E
Diethylamine	G	T
Diethylene Glycol	G	E/T/EHP
Digester Gas	G	T/S
Dimethylamine	G	T
Diethyl Phthalate	G	E/EHP
Dioxane	G	E/EHP
Dipentene (Terpene-Hydrocarbon)	C	T
Dipropylene Glycol	G	T
Dowtherm A	G	O
Dowtherm E	G	O
Dowtherm SR-1	G	T/E
Ethanolamine	G	E/EHP
Ethyl Acetoacetate	G	E/EHP
Ethyl Acrylate	G	L
Ethyl Alcohol	G	E/T/EHP
Ethyl Cellulose	C	E/EHP
Ethyl "Cellosolve"	G	E/EHP
Ethyl Chloride	G	E/EHP
Ethyl Ether	C	T
Ethyl Formate	C	V
Ethyl Oxalate	G	E/EHP
Ethyl Silicate	G	T
Ethylene Chlorohydrin	G	E/EHP
Ethylene Diamine	G	T
Ethylene Dichloride (Dichloroethane)	G	O
Ethylene Glycol	G	E/T/EHP
Ethylene Oxide	NR	—
Fatty Acids	G	A
Ferric Chloride, to 35%	G	E/T/EHP
Ferric Chloride, Saturated	G	E/EHP
Ferric Hydroxide	C	E/EHP
Ferric Nitrate	G	V
Ferric Sulfate	G	T
Ferrus Ammonium Sulfate to 30%	G	V
Fish Oils	G	A
Fluoric Acid	G	E/EHP
Fluorine Gas, Wet	NR	—
Fluorosilicic Acid	G	V
Fly Ash	G	E/EHP
Foam	G	E/EHP
Fog Oil	G	T
Formaldehyde	G	E/T/EHP
Formanide	G	T
Formic Acid	G	E/EHP
Freon 11, 130°F/54°C	G	T
Freon 12, 130°F/54°C	G	T
Freon 21	NR	—
Freon 22, 130°F/54°C	G	V
Freon 113 130°F/54°C	G	T
Freon 114, 130°F/54°C	G	T
Freon 123	NR	—
Freon 134a, 176°F/80°C	G	E/T/EHP
Fructose	G	T
Fuel Oil	G	T
Fumaric Acid	G	E/EHP
Furan	NR	—
Furfuryl Alcohol	G	E/EHP
Gallic Acid	NR	—
Gasoline, Refined	G	T
Gasoline, Refined, Unleaded	C	O
Gelatin	G	A

Chemical Composition	Rating Code	Gasket Grade
Glucose	G	A
Glue	G	T/E
Glycerin	G	E/T/EHP
Glycerol	G	E/T/EHP
Glycol	G	E/T/EHP
Glycolic Acid	C	E/EHP
Grease	G	T
Green Sulfate Liquor	G	T
Halon 1301	G	E/EHP
Heptane	G	T
Hexaldehyde	G	E/EHP
Hexane	G	T
Hexanol Tertiary	G	T
Hexyl Alcohol	G	V/T
Hexylene Glycol	G	T
Hydrobromic Acid, to 40%	G	E/EHP
Hydrochloric Acid, to 36%, 75°F/24°C	G	E/EHP
Hydrochloric Acid, to 36%, 158°F/70°C	C	O
Hydrocyanic Acid	G	E/EHP
Hydrofluoric Acid, to 75%, 75°F/24°C	G	O
Hydrofluosilicic Acid	G	T
Hydrogen Gas, Cold	C	E/T/EHP
Hydrogen Gas, Hot	C	E/EHP
Hydrogen Peroxide, to 50%	C	L
Hydrogen Peroxide, to 90%	C	O
Hydrogen Phosphide	NR	—
Hydrogen Sulfide	G	E/EHP
Hydroquinone	G	T
Hydroxylamine Sulfate	C	E/EHP
Hypochlorous Acid, Dilute	G	E/EHP
Iso Octane, 100°F/38°C	G	T
Isododecane	G	V
Isobutyl Alcohol	G	E/EHP
Isopropyl Acetate	G	E/EHP
Isopropyl Alcohol	G	E/EHP
Isopropyl Ether	G	T
JP-3	G	T
JP-4	G	T
JP-5, 6, 7, 8	G	T
Kerosene	G	T
Ketones	G	E/EHP
Lactic Acid	G	A
Lard	G	A
Lard Oil	G	V
Latex (1% Styrene & Butadiene)	G	O
Lauric Acid	G	T
Lauryl Chloride	NR	—
Lavender Oil	G	T
Lead Acetate	G	T
Lead Chloride	C	E/EHP
Lead Sulfamate	G	V
Lead Sulfate	G	T
Lime and H ₂ O	G	E/T/EHP
Linoleic Acid	G	O
Linseed Oil	G	A
Lithium Bromide	G	T
Lithium Chloride	G	T
Lubricating Oil, Refined	G	T
Lubricating Oil, Sour	G	T
Lubricating Oil, to 150°F/66°C	G	T
Lubricating Oil, 150°F/66°C to 180°F/82°C	G	V
Magnesium Ammonium Sulfate	C	V
Magnesium Chloride	G	E/T/EHP
Magnesium Hydroxide	G	E/T/EHP
Magnesium Nitrate	G	V
Magnesium Oxide	C	V
Magnesium Sulfate	G	E/T/EHP
Maleic Acid	G	T
Malic Acid	G	T
Mercuric Chloride	G	E/T/EHP
Mercuric Cyanide	G	T
Mercurous Nitrate	G	E/T/EHP
Mercury	G	T
Methane	C	T
Methyl Acetate	C	V
Methyl Alcohol, Methanol	G	E/T/EHP
Methyl Cellosolve (Ether)	G	V
Methyl Chloride	C	O

Gaskets

Chemical Composition	Rating Code	Gasket Grade
Methyl Cyclopentane	C	V
Methyl Ethyl Ketone	C	E/EHP
Methyl Isobutyl Carbinol	G	E/EHP
Methyl Isobutyl Ketone	NR	—
Methylene Chloride	C	O
Methylene Dichloride 100°F/38°C	G	O
MIL-L7808	G	O
MIL-05606	G	O
MIL-08515	G	O
Milk	G	A
Mineral Oils	G	T
Naptha, 160°F/71°C	G	O
Naphthalene	NR	—
Napthenic Acid	C	T
Natural Gas	C	T
Nevoil	G	E/EHP
Nickel Acetate to 10%, 100°F/38°C	G	V
Nickel Ammonium Sulfate	G	V
Nickel Chloride	G	E/T/EHP
Nickel Nitrate	G	V
Nickel Plating Solution 125°F/52°C	G	E/EHP
Nickel Sulfate	G	E/T/EHP
Nicotine	C	V
Nicotine Acid	C	V
Nitric Acid to 10%, 75°F/24°C	G	E/EHP
Nitric Acid, 10-50%, 75°F/24°C	G	O
Nitric Acid, 50-86%, 75°F/24°C	C	O
Nitric Acid, Red Fuming	C	O
Nitrocellulose	G	V
Nitroethane	C	E/EHP
Nitromethane	G	E/EHP
Nitrous Oxide	G	E/EHP
Octyl Alcohol	G	V
Oil, Crude Sour	G	T
Oil, Motor	G	T
Oleic Acid	G	T
Olive Oil	G	A
Oronite 8200 Silicate Ester Fluid	G	O
Orthodichlorobenzene	G	O
OS-45 Silicate Ester Fluid	G	O
OS-45-1	G	O
Oxalic Acid	G	E/EHP
Oxygen, Cold †	C	E/EHP
Ozone (100 ppm)	G	E/EHP
Palmitic Acid	G	T
Peanut Oil	G	A
Pentane	G	T
Perchloroethylene	G	O
Perchloric Acid	NR	—
Petroleum Ether (see Benzene)	G	O
Petroleum Oils	G	T
Phenol (Carbolic Acid)	G	O
Phenylhydrazine	C	E/EHP
Phenylhydrazine Hydrochloride	C	E/EHP
Phosphate Ester	G	E/EHP
Phosphoric Acid, to 50%, 70°F/21°C	G	E/EHP
Phosphoric Acid, to 85%, 200°F/93°C	G	O
Photographic Solutions	G	T
Phthalic Anhydride	G	E/EHP
Picric Acid, Molten	G	V
Plating Solutions (gold, brass, cadmium, copper, lead, silver, nickel, tin, zinc)	G	V
Polybutene	G	T
Polyvinyl Acetate, Solid (In Liquid State is 50% solution of Methanol or 60% solution of H2O)	G	E/EHP
Potassium Alum	G	E/T/EHP
Potassium Bicarbonate	G	E/T/EHP
Potassium Bichromate	G	T/E
Potassium Borate	G	E/EHP
Potassium Bromate	G	E/EHP
Potassium Bromide	G	E/T/EHP
Potassium Carbonate	G	E/T/EHP
Potassium Chlorate	G	E/EHP
Potassium Chloride	G	T
Potassium Chromate	G	T
Potassium Cyanide	G	E/T/EHP
Potassium Dichromate	G	E/EHP
Potassium Ferricyanide	G	E/EHP

Chemical Composition	Rating Code	Gasket Grade
Potassium Ferrocyanide	G	E/EHP
Potassium Fluoride	G	E/EHP
Potassium Hydroxide	G	T
Potassium Iodide	G	V
Potassium Nitrate	G	T
Potassium Perborate	G	E/EHP
Potassium Perchlorate	G	T
Potassium Permanganate, Saturated to 10%	G	E/EHP
Potassium Permanganate, Saturate 10-25%	G	E/EHP
Potassium Persulfate	G	T
Potassium Phosphate	G	V
Potassium Silicate	G	V/E/T/EHP
Potassium Sulfate	G	T
Potassium Thiosulfate	G	V
Prestone	G	T
Propane Gas	C	T
Propanol	G	E/EHP
Propargyl Alcohol	G	E/EHP
Propyl Acetate	C	V
Propyl Alcohol	G	T
Propylene Dichloride	C	L
Propylene Glycol	G	E/EHP
Pydraul F - 9 and 150	NR	—
Pyranol 1467	G	T
Pyranol 1476	G	T
Pyroguard "C"	G	T
Pyroguard "D"	G	T
Pyroguard 55	G	E/EHP
Pyrolye	G	E/EHP
Rapeseed Oil	G	A
Ref. Fuel (70 ISO Octane, 30 Toluene)	G	T
Rosin Oil	G	V/T
Salicylic Acid	G	E/EHP
Secondary Butyl Alcohol	G	T
Sewage	G	E/T/EHP
Silver Cyanide	C	V
Silver Nitrate	G	E/EHP
Silver Plating Solution	C	V
Silver Sulfate	G	E/EHP
Skydrol, 200°F/93°C	G	L
Skydrol 500 Phosphate Ester	C	E/EHP
Soap Solutions	G	E/T/EHP
Soda Ash, Sodium Carbonate	G	E/T/EHP
Sodium Acetate	G	E/EHP
Sodium Alum	G	T
Sodium Benzoate	G	E/T/EHP
Sodium Bicarbonate	G	E/T/EHP
Sodium Bisulfate	G	E/T/EHP
Sodium Bisulfite (Black Liquor)	G	E/T/EHP
Sodium Bromide	G	E/T/EHP
Sodium Carbonate	G	E/T/EHP
Sodium Chlorate	G	E/EHP
Sodium Chloride	G	E/T/EHP
Sodium Cyanide	G	E/T/EHP
Sodium Dichromate, to 20%	G	E/T/EHP
Sodium Ferricyanide	G	E/T/EHP
Sodium Ferrocyanide	G	E/T/EHP
Sodium Fluoride	G	E/T/EHP
Sodium Hydro Sulfide	G	T
Sodium Hydroxide to 50%	G	E/EHP
Sodium Hypochlorite, to 20%	G	E/EHP
Sodium Metaphosphate	G	T
Sodium Nitrate	G	E/EHP
Sodium Nitrite	G	E/T/EHP
Sodium Perborate	G	E/EHP
Sodium Peroxide	G	E/EHP
Sodium Phosphate, Dibasic	G	T
Sodium Phosphate, Monobasic	G	T
Sodium Phosphate, Tribasic	G	T
Sodium Silicate	G	T
Sodium Sulfate	G	E/T/EHP
Sodium Sulfide	G	T
Sodium Sulfite Solution, to 20%	G	T
Sodium Thiosulfate, "Hypo"	G	T
Sohovis 47	G	T
Sohovis 78	G	T
Solvasol #1	G	T

Chemical Composition	Rating Code	Gasket Grade
Solvasol #2	G	T
Solvasol #3	G	T
Solvasol #73	C	T
Solvasol #74	NR	—
Soybean Oil	G	A
Spindle Oil	G	T
Stannic Chloride	G	T
Stannous Chloride, to 15%	G	T
Starch	G	T
Steam	NR	—
Stearic Acid	G	T
Stoddard Solvent	G	T
Styrene	G	O
Sucrose Solutions	G	A
Sulfonic Acid	G	E/EHP
Sulphite Acid Liquor	G	E/EHP
Sulfur	G	V/E
Sulfur Chloride	G	O
Sulfur Dioxide, Dry	C	E/T/EHP
Sulfur Dioxide, Liquid	G	E/EHP
Sulfur Trioxide, Dry	G	O
Sulfuric Acid, to 25%, 150°F/66°C	G	E/EHP
Sulfuric Acid, 25-50%, 200°F/93°C	G	O
Sulfuric Acid, 50-95%, 150°F/66°C	G	O
Sulfuric Acid, Fuming	C	O
Sulfuric Acid, Oleum	C	O
Sulfurous Acid	G	O
Tall Oil	C	T
Tannic Acid, All Conc.	G	V
Tanning Liquors (50 g. alum. solution, 50 g. dichromate solution)	G	T
Tartaric Acid	G	E/EHP
Terpineol	G	V
Tertiary Butyl Alcohol	G	V/E/T/EHP
Tetrabutyl Titanate	G	E/EHP
Tetrachloroethylene	G	O
Tetrahydrofuran	NR	—
Tetralin	NR	—
Thionyl Chloride	C	T
Terpineol	C	T
Thiophene	NR	—
Titanium Tetrachloride	G	O
Toluene, 30%	G	T
Transmission Fluid, Type A	G	O
Triacetin	G	T
Trichloroethylene	G	O
Trichloroethylene, to 200°F/93°C	G	O
Tricresyl Phosphate	G	E/EHP
Triethanolamine	G	E/T/EHP
Trisodium Phosphate	G	E/EHP
Tung Oil	G	T
Turbo Oil #15 Diester Lubricant	G	O
Turpentine	C	T
Urea	G	T
Vegetable Oils	G	A
Vinegar	G	A
Vinyl Acetate	G	E/EHP
Vi-Pex	G	T
Water, to 150°F/66°C	G	E/T/M/S
Water, to 200°F/93°C	G	E/M
Water, to 230°F/110°C	G	E/EHP
Water, Acid Mine	G	E/T/EHP
Water, Bromine	G	V
Water, Chlorine	C	E/M
Water, Deionized	G	E/M
Water, Seawater	G	E/EHP
Water, Waste	G	E/T/M/S
Whiskey	G	A
White Liquor	G	E/EHP
Wood Oil	G	T
Xylene	C	O
Zinc Chloride, to 50%	G	E/EHP
Zinc Nitrate	G	E/EHP
Zinc Sulfate	G	E/T/EHP

Rating Code	Rating Code Key
G	Good
C	Conditional
NR	Not Recommended

Services Not Recommended

The services listed below have been tested and are NOT RECOMMENDED with any of the presently available gasket materials. Services not shown as recommended or not recommended should be submitted to Victaulic for specific recommendations.

Chemical Composition	Rating Code
Acrylonitrile	NR
Allyl Chloride	NR
Amyl Chloride	NR
Antraquinone	NR
Antraquinone Sulfonic Acid	NR
Arylsulfonic Acid	NR
Butyne Diol	NR
Chloralhydrate	NR
Chlorobromomethane	NR
Chlorosulphonic Acid	NR
Ethylene Oxide	NR
Fluorine Gas Wet	NR
Freon 21	NR
Furan	NR
Gallic Acid	NR
Hydrogen Phosphide	NR
Lauryl Chloride	NR
Methyl Isobutyl Ketone	NR
Naphthalene	NR
Perchloric Acid	NR
Pydraul F -9 and F - 150	NR
Solvasol #74	NR
Steam	NR
Tetra Hydrofuran	NR
Tetralin	NR
Thiophene	NR

Water and Air Services

	Rating Code	Gasket Grade
Air, Temp. -30°F to +230°F/ -34°C to +110°C (no oil vapors)	G	E
Dry Air, Temp. +230°F to +350°F/ +110°C to +177°C (no oil or water vapors)	G	L
Air, Oil Vapor, Temp. 0°F to +150°F/ -18°C to 66°C	G	T
Air, Oil Vapor, Temp. +150°F to +300°F/+66°C to +149°C	G	O
Water, Temp. to +150°F/+66°C	G	E/T/M/S
Water, Temp. to +200°F/+93°C	G	E/M
Water, Temp. to +230°F/+110°C*	G	E
Water, Temp. to +250°F/+120°C	G	EHP
Water, Acid Mine	G	E/T
Water, Bromine	G	V
Water, Chlorine	C	E/M
Water, Deionized	G	E/M
Water, Seawater	G	E/EHP
Water, Waste	G	E/T/M/S
Whiskey	G	A
White Liquor	G	E/EHP
Wood Oil	G	T
Xylene	C	O
Zinc Chloride, to 50%	G	E/EHP
Zinc Nitrate	G	E/EHP
Zinc Sulfate	G	E/T/EHP

* Recommended for water only. Not recommended for steam service, except where couplings are accessible for frequent gasket replacement.

NOTE: The Grade "EHP" gasket can be used on all chemical, water and air services suitable for Grade "E" gaskets.

Pipe Preparation

Roll Groove



Roll groove shown on Schedule 40 steel pipe. The small dimple created on interior pipe wall does not significantly hinder pressure or flow.

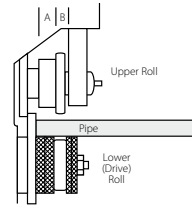

Vic-Easy tools cold form groove into pipe – maintains dimensions

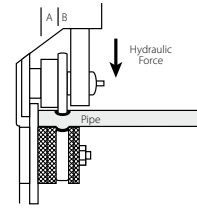

Roll grooving removes no metal from pipe

Cut Groove



Cut groove shown on Schedule 80 carbon pipe. The groove created removes less metal than threading.

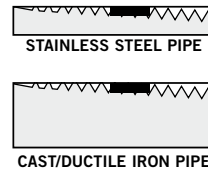

Cut groove removes less metal than threading

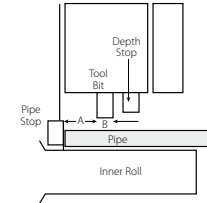

Vic-Adjustable tools provide proper groove dimensions

Roll Groovers

Field Portable

VE12, PG. 17-3
VE26, PG. 17-3
VE46, PG. 17-3
VE226, PG. 17-3



Field Fabrication

VE270FSD, PG. 17-4
VE272SFS, PG. 17-4
VE416FS/VE416FSD, PG. 17-4
VE106, PG. 17-4



Plant/Shop Fabrication

VE268, PG. 17-5
VE414MC, PG. 17-5
VE436MC, PG. 17-5
VE450FSD, PG. 17-5



Pressfit Tools

PFT505, PG. 17-11
PFT509, PG. 17-11

See pg.9-1 for the complete line of Pressfit products.



- Fast, clean and easy method for joining Schedule 5 Type 304/316 stainless steel pipe
- Available for wide variety of services based on o-ring capabilities
- Meets hanging requirements of ASME B31.1, B31.3 and B31.9
- Only approved Pressfit 304/316 pipe should be used with Pressfit 304/316 stainless steel products
- Electronically or battery operated hand-held pressing tool

Cut Groovers

Field Manual

VG28GD, PG. 17-8
VG824, PG. 17-8
VG828, PG. 17-8

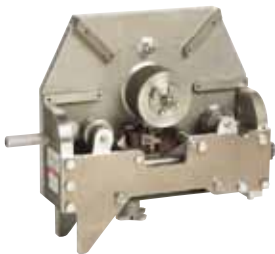

Field Motorized

VG412, PG. 17-9
VIC-GROOVER, PG. 17-9



Plastic Groovers

VPG26, PG. 17-9
VPG824, PG. 17-9



Pipe Preparation

Cutting Tools

Hole Cutting

HCT908, PG. 17-11
 VHCT900, PG. 17-11
 VIC-TAP® II, PG. 17-11



Pipe Cutting

VCT1, PG. 17-12
 VCT2, PG. 17-12



Pipe Coatings

To maintain the published performance levels with respect to maximum rated working pressure and end load, the maximum coating thickness on our couplings should not exceed 10mils/0.010". If additional protection is required, the coating thickness may be increased on the external surfaces of the coupling key, shoulder, gasket pocket or bolt pad mating surfaces. In addition, the coating thickness on the pipe ends should not exceed 10mils. Specifically, the gasket seating surface and the entire groove should have coating thickness limited to 10mils.

Exceeding the maximum thickness on either the pipe end or coupling surfaces mentioned above will decrease the performance capabilities of the pipe joints.

Accessories

Power Drive

VPD752, PG. 17-13
 VE224 POWER DRIVE KIT, PG. 17-13



Power Mule

PG. 17-13



Adjustable Pipe Stands

VAPS112, PG. 17-13
 VAPS224, PG. 17-14



Pipe Diameter Tape

PG. 17-14



PRODUCTS

- 1-1 Couplings
- 2-1 Fittings
- 3-1 Valves
- 4-1 Accessories
- 5-1 Advanced Groove System
- 6-1 Hole Cut Piping System
- 7-1 Plain End Piping System
- 8-1 Grooved System for Stainless Steel Pipe
- 9-1 Pressfit System for Stainless Steel Pipe
- 10-1 Plain End Piping System for HDPE Pipe
- 11-1 Grooved Copper
- 12-1 PermaLynx System for Copper Tube
- 13-1 Grooved AWWA Ductile Iron Pipe
- 14-1 Victaulic Depend-O-Lok System
- 15-1 Aquamine Reusable PVC Products
- 16-1 Gaskets
- 17-1 Pipe Preparation Tools**
- 18-1 Product Index
- 19-1 Piping Software

Pipe Preparation – Roll Grooving Tools

Field Portable

For Complete Information
Request Publication **24.01**



VE12

VE12 GROOVE IN-PLACE

- For manual grooving of Schedule 5, 10 and 40 steel; stainless steel; aluminum and PVC pipe
- Enhanced tracking rolls allow bi-directional grooving
- Roll grooves $\frac{3}{4}$ –2 $\frac{1}{2}$ –50mm pipe†

Power Requirements: None

Weight: 17lbs./8kg



VE26

VE26 GROOVE IN-PLACE

- Repair and retrofit existing lightwall steel, Schedule 40 steel, stainless steel, PVC, and aluminum
- Patented enhanced tracking rolls allow bi-directional grooving
- Model VE26C handles copper tubing (CTS) Types K, L, M and DWV plus British, DIN, and Australian Standard copper
- Model VE26SS grooves Schedule 5 and 10 stainless steel
- Optional power drive adapter kit available to alternately groove pipe using a Ridgid* 300 power drive or VPD752
- Roll grooves 2–6 $\frac{1}{2}$ –150mm pipe†

Power Requirements: None

Weight: 22lbs./10kg



VE46

VE46 GROOVE IN-PLACE

- Designed for manually roll grooving Schedule 40 steel, aluminum, stainless steel and PVC pipe and Schedule 80 PVC pipe
- Patented enhanced tracking rolls allow bi-directional grooving and helps to hold the tool on the pipe end during the roll grooving process
- Optional power drive adapter kit available to alternately groove pipe using a Ridgid* 300 power drive or VPD752
- Roll grooves 3 $\frac{1}{2}$ –6 $\frac{1}{2}$ –150mm pipe†

Power Requirements: None

Weight: 28lbs./13kg



VE226

VE226 PORTABLE GROOVER

- Mounts to a Victaulic VPD752 or Ridgid* 300 power drive
- Optional alternate bases available
- Tool is operated using a standard $\frac{3}{8}$ "/9.5mm square ratchet drive (not included)
- Available in six models for steel (and other IPS) pipe, copper tubing and stainless steel
- Roll grooves $\frac{3}{4}$ –6 $\frac{1}{2}$ –150mm pipe†

Drive Requirements: Fits Victaulic VPD752 or Ridgid 300 power drives.

Optional bases for Ridgid* 535, 1224, 1822, and Oster 310 available. Contact Victaulic for others.

Weight: 37lbs./17kg

† Refer to Roll Grooving Tool Ratings chart on pgs. 17-6, 17-7

* Ridgid is a registered trademark of the Ridge Tool Company

VE26/46 Power Drive Kit



The VE26/46 power drive kit is available to allow both tools to be directly mounted to either a Victaulic VPD752 or Ridgid* 300 Power Drive.

VE226 Power Drive Kit



The VE226 Power Drive Kit is available to allow the VE226 to be directly mounted to a Ridgid* 700 power drive

Pipe Preparation – Roll Grooving Tools

Field Fabrication

For Complete Information
Request Publication 24.01



VE106

VE106/VE107 GROOVE-N-GO

- Mobile light-duty roll grooving tool with an integral motor/drive unit mounted to portable hand truck
- $\frac{3}{8}$ "/9.5 mm square ratchet drive for operation (standard)
- Patented enhanced tracking rolls help to keep the pipe on the tool during the roll grooving process
- Completely self-contained unit with an integral motor, safety foot switch and power plug
- Roll grooves 1 $\frac{1}{4}$ –6"/32–150mm pipe[†]

Power Requirements: VE106 is provided with 110volt, 15amp power. VE107 is provided with 220volt, 6amp power.

Weight: 140 lbs./64 kg

Optional Accessories: Additional rolls/shafts are available for copper, lightwall stainless steel, and EndSeal (ES) grooving.



VE270FSD

VE270FSD

- Completely self-contained unit with integral gear motor, safety guards, safety foot switch and power cord/plug
- Equipped with a unique pivot arm design, making roll changing quick and easy, without removing shafts
- Patented enhanced tracking rolls help to keep the pipe on the tool during the roll grooving process
- Roll grooves $\frac{3}{4}$ –12"/20–300mm pipe[†] (Supplied with 2-12"/50-300mm roll sets)

Drive Requirements: Self-contained

Power Requirements: VE270FSD is provided with 110volt, 15amp power. VE271FSD is provided with 220volt, 6amp power.

Weight: 340 lbs./154 kg

Optional Rolls: Carbon steel Schedules 5, 10, 20, and 40; copper rolls for type K, L, M and DWV; and stainless steel Rx rolls for Schedules 5S-10-10S, and $\frac{3}{4}$ –1 $\frac{1}{2}$ "/20–40mm steel pipe.

Optional Accessories: An optional pipe stabilizer for 8–12"/200–300mm pipe is available.



VE272SFS

VE272SFS

- Portable roll groover mounts easily to the Victaulic VPD752 or Ridgid 300 power drive
- Hand pump operation with a unique pivot arm design reduces handle effort
- Patented enhanced tracking rolls help you keep the pipe on the tool during the roll grooving process
- Roll grooves $\frac{3}{4}$ –12"/20–300mm pipe[†] (Supplied with 2-12"/50-300mm roll sets)

Power Requirements: Victaulic VPD752 or Ridgid* 300 power drive

Weight: 184 lbs./84 kg

Optional Rolls: Optional rolls are available for copper pipe; Schedule 5S, 10S, and 10 stainless steel pipe; and EndSeal (ES) grooving.

Optional Accessories: An optional pipe stabilizer for 8-12"/200-300mm pipe is available.



VE416FSD

VE416FS/VE416FSD

- For field roll grooving of 2–16/50–400mm standard wall pipe, lightwall steel pipe, as well as aluminum, stainless and PVC plastic pipe
- Equipped with a pipe stabilizer for 6–16/150–400mm pipe sizes to control pipe sway
- Groove depth adjuster provides for easy adjustment for initial groove diameter
- Completely self-contained units with integral gear motors, safety foot switch and power cord/plug
- Roll grooves 2–16"/50–400mm pipe[†]

Power Requirements: VE416 requires Victaulic VPD752 or Rigid* 300 Power Drive. VE416FSD is provided with 110volt, 15amp for integral gear motor. VE417FSD is provided with 220volt, 8amp service.

Weight: 340 lbs./154 kg

Optional Rolls: Optional rolls are available for Schedule 5S and 10S stainless steel pipe, PVC and aluminum pipe, and types K, L, M and DWV copper tubing.

AGS roll sets for 14-16"/350-400mm std. wall carbon steel pipe are now standard.

[†] Refer to Roll Grooving Tool Ratings chart on pgs. 17-6, 17-7

Pipe Preparation – Roll Grooving Tools

Plant/Shop
Fabrication

For Complete Information
Request Publication 24.01



VE268



VE414MC



VE436MC



VE450FSD

VE268

- Designed for fabrication shop roll grooving
- The fully-motorized, semi-automatic, electrohydraulic tool comes complete with safety guards and safety foot switch
- Equipped with a unique pivot arm design, making roll changes quick and easy, without removing shafts
- Patented enhanced tracking rolls help to keep the pipe on the tool during the roll grooving process
- Roll grooves $\frac{3}{4}$ –12"/20–300 mm pipe† ($\frac{3}{4}$ –1½"/20–32mm rolls are optional)

Drive Requirements: Self-contained

Weight: 735 lbs./333 kg

Optional Rolls: Optional rolls are available for carbon steel Schedules 5, 10, and 40; copper rolls for type K, L, M and DWV; and stainless steel Rx rolls for Schedules 5S, 10, and 10S, and $\frac{3}{4}$ –1½"/20–40mm steel pipe.

Optional Accessories: An optional pipe stabilizer for 8–12"/200–300 mm pipe is available and is suggested for grooving 8"/206.4mm copper tubing.

VE414MC

- Designed for fabrication shop roll grooving Schedule 5, 10, and standard wall carbon steel pipe, standard wall stainless steel pipe, Schedule 40, 80 PVC pipe, and standard wall aluminum pipe
- Unique roll design, making roll changing quick and easy, without removing main shafts
- Patented enhanced tracking rolls help to keep the pipe on the tool during the roll grooving process
- The tool comes equipped with pipe stabilizers to provide smooth grooving operation
- Roll grooves 2–16"/50–400 mm pipe† (Supplied with 2-12"/50-300mm original rolls and 14-16"/350-400mm AGS rolls)

Drive Requirements: Self-contained

Weight: 735 lbs./333 kg

Optional Rolls: Optional rolls are available for Schedule 10S stainless steel pipe PVC and aluminum pipe and type K, L, M and DWV copper tubing. AGS roll sets for 14-16"/350-400mm Schedule 10 through .500"/12.7mm wall carbon steel pipe are now standard.

Optional Accessories: The tool can also be supplied in various voltages, contact Victaulic for details.

VE436MC

- Fully automated shop tool for roll grooving standard wall (.375"/9.5mm wall maximum) pipe
- The fully-motorized, semi-automatic, electro-hydraulic tool comes complete with safety guards and safety foot switch
- Patented enhanced tracking rolls help to keep the pipe on the tool during the roll grooving process
- Roll grooves 4–36"/100–900 mm pipe† (26-36/650-950mm roll kit optional)

Power Requirements: 220/440volt, 3 phase, 60Hz (shipped wired for 220volt unless otherwise specified). Contact Victaulic for details.

Weight: 1500 lbs./680 kg

Optional Rolls: Optional rolls are available for Schedule 5S and 10S stainless steel pipe, PVC and aluminum pipe, and types K, L, M and DWV copper tubing.

AGS roll sets for 14 – 16"/350 – 400 mm Schedule 10 through .500"/12.7 mm wall carbon steel pipe are now standard.

VE450FSD

- Designed for field roll grooving of 4 – 24"/100 – 600 mm pipe
- Tool is supplied with roll sets for grooving 4 – 12"/100 – 300 mm original groove and 14 – 24"/350 – 600 mm AGS groove on carbon steel pipe
- Patented enhanced tracking rolls help to keep the pipe on the tool during the roll grooving process, and quick change upper roll design
- Features:
 - Lifting point to move the tool using a crane
 - Frame can accept most fork lifts
 - On board storage for tool accessories

Power Requirements: VE450FSD is a self-contained unit with two 220 volt, single phase 50/60 hz, 20 amp integral gear motors to handle heavier loads, safety foot switch and power cord/plug

Weight: 825 lbs./374 kg

Optional Rolls: Optional rolls are available for 14 – 24/350 – 600 mm carbon steel original groove; 4 – 12/100 – 400 mm lightwall stainless steel original groove; 14 – 24/350 – 600 mm lightwall stainless steel AGS groove; and 4 – 12/100 – 400 mm EndSeal (ES) groove.

† Refer to Roll Grooving Tool Ratings chart on pgs. 17-6, 17-7

Pipe Preparation – Roll Grooving

Vic-Easy® Roll Grooving Tool Ratings

(MAXIMUM CAPACITY)

Victaulic Vic-Easy roll grooving tools are designed to cold form grooves into the specified pipe to meet ANSI/AWWA C-606 standards and the groove dimensions specified in Victaulic Groove Specifications for each type of pipe.

These tools are designed for roll grooving pipe. To accomplish this function requires some dexterity and mechanical skills, as well as sound safety habits. Although this tool is manufactured for safe dependable operation, it is impossible to anticipate those combinations of circumstances which could result in an accident. The operator is cautioned to always practice "Safety First" during each phase of use, including setup and maintenance of these units.

Read and understand the Tool Operating and Maintenance Instruction Manual provided with each tool before operating or performing maintenance on tools. Become familiar with the tool's operations, applications and limitations. Be particularly aware of its specific hazards.

IMPORTANT NOTES:

- **PVC grades that can be grooved –**
PVC Type I Grade I – PVC 1120;
PVC Type I Grade II – PVC 1220;
PVC Type II Grade I – PVC 2116.

- **Copper/nickel pipe –**
contact Victaulic for details.

Note: Vic-Easy tools and rolls shown on this chart will produce grooves in accordance with Victaulic Roll Groove Dimension charts and to ANSI/AWWA C-606 standards.

Tool Model	Pipe Material	Pipe Size/Schedule Inches/mm																			
		¾ 20	1 25	1¼ 32	1½ 40	2 50	2½ 65	3 80	3½ 90	4 100	4½ 120	5 125	6 150	8 200	10 250	12 300	14 350	16 400			
VE12	Steel	5, 10	5 – 40																		
	Stainless		40S only																		
	Aluminum †	5, 10	5 – 40																		
	PVC Plastic		40																		
VE26S	Steel					5 – 40		5, 10													
	Stainless					40S only															
VE26P	Aluminum †					5 – 40		5, 10													
	PVC Plastic					40															
VE26C	Copper					K, L, M, DWV Copper Rolls ‡															
VE26SS	Lt. Wall SS					5S, 10S Rx Rolls #															
VE46	Steel									5 – 40											
	Stainless									40S only											
VE46P	Aluminum †									5 – 40											
	PVC Plastic								40	40, 80											
VE226S	Steel					5 – 40		5, 10													
	Stainless					40S only															
VE226P	Aluminum †					5 – 40				5, 10											
	PVC Plastic					40, 80				40											
VE226B	Steel	5 – 40																			
	Stainless	40S only																			
	Aluminum †	5 – 40																			
	PVC Plastic	40	40, 80																		
VE226M	Steel					5 – 40		5, 10													
	Stainless					40S only															
VE226C	Copper					K, L, M, DWV Copper Rolls ‡															
VE226BSS	Lt. Wall SS	5S, 10S Rx Rolls #																			
VE226MSS	Lt. Wall SS					5S, 10S Rx Rolls #															
VE106	Steel					5 – 40 Standard Rolls §															
	Stainless					40S Standard Rolls §															
	Lt. Wall SS					5S, 10S Rx Rolls #															
	Copper					K, L, M, DWV Copper Rolls ‡															
VE272SFS	Steel	5 – 40S Standard Rolls §													5 – 20 Std.						
	Stainless	40S Standard Rolls §																			
	Lt. Wall SS	5S, 10S Rx Rolls #																			
	Aluminum †	5 – 40 RP Rolls ◊													5 – 20 RP ◊						
	PVC Plastic	40 RP Rolls ◊				40, 80 RP Rolls ◊								40 RP ◊							
	Copper					K, L, M, DWV Copper Rolls ‡															
VE270FSD	Steel	5 – 40S Standard Rolls §													5 – 20 Std.						
	Stainless	40S Standard Rolls §																			
	Lt. Wall SS	5S, 10S Rx Rolls #																			
	Aluminum †	5 – 40 RP Rolls ◊													5 – 20 RP ◊						
	PVC Plastic	40 RP Rolls ◊				40, 80 RP Rolls ◊								40 RP ◊							
	Copper					K, L, M, DWV Copper Rolls ‡															

TABLE CONTINUED ON PG. 17-7

Rx Rolls – "Rx" is the Victaulic part code designator for grooving roll sets specifically designed for roll grooving lightwall stainless steel pipe.

† 6061-T4 or 6063-T4 alloy must be used.

‡ Alternate units are available for European Standard (EN) 1057 and Australian Standard Copper.

§ Standard Rolls – This is the Victaulic designation for grooving roll sets used primary for steel pipe. Also used for Schedule 40S stainless steel pipe.

◊ RP Rolls – "RP" is the Victaulic part code designator for grooving roll sets specifically designed for roll grooving PVC plastic pipe and aluminum pipe.

Pipe Preparation – Roll Grooving

Vic-Easy Roll Grooving Tool Ratings

(MAXIMUM CAPACITY)

Victaulic Vic-Easy roll grooving tools are designed to cold form grooves into the specified pipe to meet ANSI/AWWA C-606 standards and the groove dimensions specified in Victaulic Groove Specifications for each type of pipe.

These tools are designed for roll grooving pipe. To accomplish this function requires some dexterity and mechanical skills, as well as sound safety habits. Although this tool is manufactured for safe dependable operation, it is impossible to anticipate those combinations of circumstances which could result in an accident. The operator is cautioned to always practice "Safety First" during each phase of use, including setup and maintenance of these units.

Read and understand the Tool Operating and Maintenance Instruction Manual provided with each tool before operating or performing maintenance on tools. Become familiar with the tool's operations, applications and limitations. Be particularly aware of its specific hazards.

IMPORTANT NOTES:

- **PVC grades** that can be grooved – PVC Type I Grade I – PVC 1120; PVC Type I Grade II – PVC 1220; PVC Type II Grade I – PVC 2116.
- **Copper/nickel pipe** – contact Victaulic for details.
- **Light weight stainless steel pipe** (Sch. 10S and Sch. 5S) must be grooved using stainless Rx roll sets.

Note: Vic-Easy tools and rolls shown on this chart will produce grooves in accordance with Victaulic Roll Groove Dimension charts and to ANSI/AWWA C-606 standards.

- # Rx Rolls – "Rx" is the Victaulic part code designator for grooving roll sets specifically designed for roll grooving lightwall stainless steel pipe.
- † 6061-T4 or 6063-T4 alloy must be used.
- ‡ Alternate units are available for European Standard (EN) 1057 and Australian Standard Copper.
- § Standard Rolls – This is the Victaulic designation for grooving roll sets used primary for steel pipe. Also used for Schedule 40S stainless steel pipe.
- ◇ RP Rolls – "RP" is the Victaulic part code designator for grooving roll sets specifically designed for roll grooving PVC plastic pipe and aluminum pipe.
- ⊖ RW Rolls – "RW" is the Victaulic part code designator for grooving roll sets specifically designed for roll grooving standard well pipe to AGS specifications.
- ⊞ RWx Rolls – "RWx" is the Victaulic part code designator for grooving roll sets specifically designed for roll grooving lightwall stainless steel pipe to AGS specifications.
- + Special rolls for grooving true Sch. 10 (.25"/6.4mm) are available.

Tool Model	Pipe Material	Pipe Size/Schedule Inches/mm																	
		¾ 20	1 25	1¼ 32	1½ 40	2 50	2½ 65	3 80	3½ 90	4 100	4½ 120	5 125	6 150	8 200	10 250	12 300	14 350	16 400	
TABLE CONTINUED FROM PG. 16-6																			
VE416FS/ VE416FSD Original Groove	Steel																5 – 40S Standard Rolls §	5 – Std. Wall **	
	Stainless																	40S Standard Rolls §	Std. Wall Only **
	Lt. Wall SS																	5S, 10S Rx Rolls #	5S-10 Rx Rolls #
	Aluminum †																	5 – 40 RP Rolls ◇	5-Std.
	PVC Plastic																	40, 80 RP Rolls ◇	40 RP ◇
	Copper																	K, L, M, DWV Copper Rolls ‡	
VE416FS/ VE416FSD AGS Groove	Steel																		Std. Wall RW Rolls ⊖
	Stainless																		Std. Wall RW Rolls ⊖
	Lt. Wall SS																		5S-10 RWx Rolls ⊞+
VE268	Steel																	5 – 40S Standard Rolls §	5 – 20 Std. Rolls §
	Stainless																	5 – 40S Standard Rolls §	
	Lt. Wall SS																	5S, 10S Rx Rolls #	
	Aluminum †																	5 – 40 RP Rolls ◇	5 – 20 RP Rolls ◇
	PVC Plastic																	40 RP Rolls ◇	40, 80 RP Rolls ◇
	Copper																	K, L, M, DWV Copper Rolls ‡	
VE414MC Original Groove	Steel																	5 – 40S Standard Rolls §	5 – Std. Wall **
	Stainless																	40S Standard Rolls §	Std. Wall Only**
	Lt. Wall SS																	5S, 10S Rx Rolls #	5S-10 Rx Rolls #
	Aluminum †																	5 – 40 RP Rolls ◇	5-Std.
	PVC Plastic																	40, 80 RP Rolls ◇	40 RP ◇
	Copper																	K, L, M, DWV Copper Rolls ‡	
VE414MC AGS Groove	Steel																		Std. Wall RW Rolls ⊖
	Stainless																		Std. Wall RW Rolls ⊖
	Lt. Wall SS																		5S-10 RWx Rolls ⊞+

** For standard wall thickness, see pg. 17-16

@ Special RWX rolls for grooving true sch. 10 (0.250-6.4mm) are available.

RX Rolls - "RX" is the Victaulic part code designator for grooving roll sets specifically designed for roll grooving light-wall stainless steel pipe.

† 6061-T4 or 6063-T4 alloy must be used.

◇ RP Rolls - "RP" is the Victaulic part code designator for grooving roll sets specifically designed for roll grooving PVC plastic pipe and aluminum pipe.

Tool Model	Pipe Material	Pipe Size/Schedule Inches/mm															
		4 100	5 125	6 150	8 200	10 250	12 300	14 350	16 400	18 450	20 500	22 550	24 600	26 650	28 700	30 750	32 800
VE436MC Original Groove	Steel	5-80 *				5-40 *				5-0.500"/12.7 mm Wall *							
	Stainless	40S Standard Rolls §				0.375"/9.5 mm Wall Standard Rolls §											
	Lt. Wall SS	5S, 10S Rx Rolls #				5S, 10S, 10 Rx Rolls #											
	Aluminum †	5 – 40 RP Rolls ◇															
VE436MC AGS Groove	Steel					Std. Wall 0.375"/9.5 mm RW Rolls ⊖											
	Stainless					Std. Wall 0.375"/9.5 mm RW Rolls ⊖											
	Lt. Wall SS					5S, 10S RWx Rolls ⊞+											
VE450FSD	Steel	5-40				Sch. 5 - Std. Wall Original Groove Only				Sch. 10 & Std. Wall RW-AGS							
	Stainless	40S Standard Rolls §				Sch. Wall, Std. Rolls				Std. Wall RW-AGS							
	Lt. Wall SS	5S, 10S Rx Rolls @				5S, 10S, 10 Rx Rolls											
	AGS Lt. Wall SS					10S Rx Rolls #											
	Aluminum †	5 – 40 RP Rolls															
	PVC Plastic*	40 – 80				40											

‡ EndSeal (ES) rolls are available. Contact Victaulic for details.

@ These rolls are not interchangeable with rolls sets from other tool models. Contact Victaulic for ordering information.

* Use RP Rolls.

† 6061-T4 or 6063-T4 must be used. RP Rolls must be used.

Special RWX rolls for grooving true sch. 10 (0.250 – 6.4 mm) are available.

Pipe Preparation – Cut Grooving Tools

Field Manual

For Complete Information
Request Publication **24.01**



VG28GD

VG28GD VIC-ADJUSTABLE™

- Designed for fast, easy cut grooving of steel and other metallic IPS and ductile iron pipe
- A modified version (MRL) is available to groove and machine for rubber lining
- Cut grooves 2 - 8"/50-200mm pipe†

Drive Requirements: External drive, minimum 1½ hp

Drive Speed: 38rpm maximum

Shipped Set For: Standard groove 4–6"/100–150mm steel pipe. Contact Victaulic for ductile iron, MRL, and double groove requirements.

Weight: 37 lbs./17 kg



VG824

VG824 VIC-ADJUSTABLE

- Designed for cut grooving various metallic pipe materials
- The tool must be driven through its own integral gear box by an external power source at a maximum speed of 38 rpm
- Ideal for job site, fab shop or production cut grooving
- Cut grooves 8 - 24"/200-600mm pipe†

Drive Requirements: External drive, minimum 1½ hp

Drive Speed: 38rpm maximum

Shipped Set For: Standard groove, 8–12"/200–300mm steel pipe

Weight: 82 lbs./37.2 kg

Options: 8" standard tool bit – 0.437"/11 mm; 8–24"/200–650mm standard tool bit – cast/ductile pipe; 22–24" standard tool bit – 0.563"/14 mm

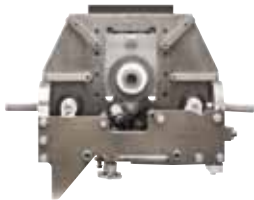

VG828

VG828 AGS CUT GROOVING TOOL

- Designed for cut grooving .500"/12.7mm or heavier carbon steel pipe from 14 – 24"/350-600mm
- The tool must be driven through its own integral gear box by an external power source at a maximum speed of 38 rpm
- Ideal for job site cut grooving
- Designed for AGS systems only

Drive Requirements: External drive, minimum 1½ hp

Drive Speed: 38rpm maximum

Shipped Set For: 14-24"/355-609mm AGS cut grooves only

Weight: 125 lbs./56.7 kg

Pipe Preparation – Cut Grooving Tools

Field Groover

For Complete Information
Request Publication 24.01



VG46

VG46 VIC-GROOVER

- Designed for manual or power cut grooving of a single size on steel, stainless steel, aluminum and PVC pipe
- Tools are supplied with a ratchet handle for manual operation
- Tools 2"/50mm and larger are supplied with a power yoke
- Cut grooves ¾–8"/20–200mm pipe†

Drive Requirements: Manual or external drive, minimum ½hp./0.37kw

Drive Speed: 40rpm maximum

Shipped Set For: Standard groove, IPS of size indicated or rigid/flexible for ductile/cast pipe

Weight: 28lbs./13kg

† Refer to Cut Grooving Tool Ratings chart on pgs. 17-10

Field Motorized

For Complete Information
Request Publication 24.01



VG412

VG412 ORBITAL MACHINING TOOL

- Complete modular pipe end preparation system providing quick, accurate cutting and grooving of ductile iron pipe to meet AWWA and other industry specifications for mechanical couplings
- External mounting and drive action is particularly suited to cement lined ductile iron pipe grooving
- The hinged frame design allows cutting at any point along the pipeline
- Blade setting and replacement is fast and easy
- Cut grooves 4–12"/100–300mm pipe†
- Safety foot switch

Drive Requirements: 120 volt/11.5 amp

Shipped Set For: Rigid Radius Groove, 4–12"/100–300mm ductile iron pipe

Weight: 151 lbs./69kg

Options: 4–12"/100–300mm IPS steel kit; flexible groove profile components

Plastic Groovers

For Complete Information
Request Publication 24.01



VPG26

VPG26 AND VPG824

- PVC plastic pipe requires a radius groove to reduce any point of stress concentration in this notch sensitive material
- Tools feature a high speed, router-type tool bit which cuts a radiused groove, to full depth, in one manual rotation of the tool around the pipe

VPG26

- Grooves 2-6"/50-150mm pipe

Power Requirements: 110volt, 1 phase, 60Hz, 7 amps

Rotation Drive: Manual (clockwise)

Weight: 41 lbs./19 kg

Shipped Set For: VPG26 for 2–3 ½"/50–90mm

VPG824

- Grooves 8-16"/200-400mm pipe

Power Requirements: 110volt, 1 phase, 60Hz, 7 amps

Weight: 47 lbs./21 kg

Shipped Set For: VPG824 for 8–12"/200–300mm



VPG824

† Refer to Cut Grooving Tool Ratings chart on pgs. 17-10

Pipe Preparation – Pressfit Tool/Hole Cutting Tools

Pressfit Tool

For Complete Information
Request Publication 24.01



PFT505

PFT505 – ELECTRIC TOOL

- The Pressfit System requires a Pressfit tool designed for securing Pressfit products onto pipe
- Jaws are available separately for rental (with rental tool) or purchase
- Pressfit tool is designed for industrial and trade use only

Capacity: ½–2"/15–50 mm IPS Schedule 5 steel and stainless steel pipe

Power Requirements: 110volt, 60cycle, 6.5 amp

Accessories: Pressing jaws in ½"/15 mm, ¾"/20 mm, 1"/25 mm, 1½"/40 mm and 2"/50 mm

Note: PFT505 and PFT509 components are not interchangeable



PFT509

PFT509 – BATTERY TOOL

- The Pressfit System requires a Pressfit tool designed for securing Pressfit products onto pipe
- Tool packages include the actual pressing tool, two (2) batteries and a charger, carrying case, and ½, ¾, 1, and 1½" press jaws
- Jaws are available separately for purchase
- Pressfit tool is designed for industrial and trade use only
- Pressfit tool is battery powered and requires a 12V battery charger

Capacity: ½ – 1" and 1½"/15 – 25 mm and 40 mm IPS Schedule 5 steel and stainless steel pipe

Note: PFT505 and PFT509 components are not interchangeable

Hole Cutting Tools

For Complete Information
Request Publication 24.01



HCT908

HCT908

- One-piece hole cutting tool designed to cut holes up to 4½"/120 mm in carbon and stainless steel pipe
- Allows for use of Mechanical-T, Vic-Let, and Vic-O-Well outlets

Capacity: 1–4½"/25–120 mm holes for ½–4"/15–100 mm Mechanical-T and Vic-Let connections

Power Requirements: 110volt, 1 phase, 60 Hz, 7.0 amp

Weight: 23 lbs./10 kg



VHCT900

VHCT900

- Three-piece hole cutting tool designed to cut holes up to 3½"/90 mm in diameter for Mechanical-T, Vic-Let, and Vic-O-Well outlets
- Base unit clamps quickly onto the pipe in vertical, horizontal or overhead positions
- Heavy-duty drill mounts to the alignment guides and a manual feed assembly provides uniform pressure on the saw for maximum cutting efficiency

Capacity: 1–3½"/25–90 mm holes for ½–3"/15–80 mm Mechanical-T and Vic-Let connections

Power Requirements: grounded 120volt, 1 phase, 60 Hz, 10 amp electrical supply.
(220 volt, 1 phase, 60 Hz, 5 amp available on request)

Weight: 36 lbs./16 kg

Accessories: Extended chain for 10–24"/250–600 mm pipe



VIC-TAP II

VIC-TAP II

- Hole cutting tool designed for use with Style 931 Vic-Tap II Mechanical-T unit for tapping into steel pipe systems under pressures up to 500 psi/3450 kPa

Capacity: Vic-Tap II 4–8"/100–200 mm Run × 2½"/65 mm (IPS) Outlet

Power Requirements: 115volt, 1 phase, 60 Hz, 7.5 amp

Weight:

(A) Drill guide base 15 lbs./6.8 kg

(B) Drill motor and feed assembly, total wgt. 16 lbs./7.3 kg

(C) Style 931/Valve unit, 12 lb./5.4 kg – 15 lb./6.8 kg, depending upon size (4, 5, 6 and 8"/100, 125, 150 200 mm available)

Hole Size: 2¾"/60.5 mm

Pipe Preparation – Pipe Cutting Tools

Pipe Cutting Tools

For Complete Information
Request Publication **24.01**



VCT1

VCT1 MANUAL

- Lightweight and portable pipe cut-off tool handles 4–24"/100–600 mm pipe, up to 0.500/12.7 mm thick
- Worm gear drive crank handle provides smooth, manual travel, easy control and accurate cutting

Capacity: 4–24"/100–600 mm

Wall Thickness: 0.065–0.500"/1.65–12.7 mm (with tips supplied)

Tips: Acetylene – 1 ea. #00, #0, #1

Weight: 22 lbs./10 kg



VCT2

VCT2 AUTOMATIC

- Rotation is powered by a small 120VAC motor with SCR remote control
- Unique distributor design has stainless steel insert which extends tip life, eases cleaning and reduces backfire

Capacity: 6–24"/150–600 mm

Wall Thickness: 0.065–0.500"/1.65–12.7 mm (with tips supplied)

Tips: Acetylene – 1 ea. #00, #0, #1

Speed Control: SCR

Power Required: 120 volt, 1 phase, 60Hz, 15 amp

Motor Rating: 15W 10,000rpm

Weight: 33 lbs./15 kg

Accessories: Guide rail is sold separately. Recommended for pipe 12"/300 mm and above. Order Guide Rail D-600 for up to 24"/600 mm pipe (others available).

Pipe Preparation – Accessories

Power Drive

VPD752

For Complete Information
Request Publication 24.01



- Can be used as the power drive unit for the VE226, VE26, VE46, VE416FS and VE272SFS roll grooving tools, provided the tool is equipped with the correct base plate and the VG1, VG28GD, and VG824 cut grooving tools with universal drive shaft
- Operated with a safety foot switch

Capacity: See appropriate tool

Power Requirements: 115 volts, 15 amp, 50/60 Hz (220 volt, 6 amp, 50/60 cycle optional)

Weight: 140 lbs./634 kg

Optional: Universal drive shaft

Power Mule

For Complete Information
Request Publication 24.01



- Ideal drive for Victaulic individual Vic-Groover tools, VG28GD, VG824 and VG828
- Heavy-duty, two-wheeled unit drives Victaulic cut grooving tools at the speed and power necessary for accurate grooving
- Power Mule is equipped with a Forward-Off-Reverse control and integral foot switch

Capacity: Victaulic individual Vic-Groover tools, VG28GD, VG26GD/MRL, VG824, VG824/MRL

Power Requirements: 115 volts, 15 amp, 50/60 cycle

Full Load Speed: 35 rpm

Weight: 190 lbs./86 kg

Adjustable Pipe Stand

VAPS112

For Complete Information
Request Publication 24.01



- Designed for supporting pipe to be roll grooved
- Four adjustable legged portable self-standing unit
- Turnstile design allows pipe to be spun around for grooving of both pipe ends without dismounting pipe from stand

Capacity: ¾–12"/20–300 mm IPS pipe

Load Rating: 1075 lbs./490 kg

Vertical Stroke: 14½"/368 mm for adjusting rod, 8½"/216 mm leg adjustment, 23"/584 mm

Minimum Pipe Height from Floor:

23"/584 mm on 12"/300 mm pipe

21"/533 mm on 1"/25 mm pipe

Weight: 190 lbs./86 kg

Handle Effort Required to Raise 1075 lbs./490 kg Load: 50 lbs./23 kg maximum

Pipe Preparation – Accessories

Adjustable Pipe Stand

VAPS224

For Complete Information
Request Publication 24.01



- Designed specifically for supporting pipe to be roll grooved
- Self-standing heavy-duty unit permits free pipe rotation and traversing on ball transfers
- Ball transfers are mounted in a manner permitting use of pipe slings
- Turnstile design allows pipe to be spun around for grooving of both pipe ends without dismounting pipe from stand

Capacity: 2–24"/50–600 mm IPS pipe

Load Rating: 1800 lbs./816 kg

Vertical Stroke: 23"/584 mm

Minimum Pipe Height from Floor: 13"/325 mm on 24"/600 mm IPS pipe

Maximum Pipe Height from Floor: 38"/965 mm on 2"/50 mm IPS pipe

Weight: 260 lbs./118 kg

Handle Effort Required to Raise 1800 lbs./817 kg Load: 50 lbs./23 kg maximum

Pipe Diameter Tape PT100A

For Complete Information
Request Publication 24.01



- Tape contains Go/No-Go markings on one side for use with ¾ – 24"/20 – 600 mm pipe in ANSI B36.19 and many ISO-4200 sizes and is marked in 1/100th of an inch increments on the other side.
- The Go/No-Go side can be used to check cut or roll grooved pipe conformance to Victaulic original and Machined for Rubber Lining (MRL) (¾ – 12"/20 – 300 mm) and Advanced Groove System (AGS) (14 – 24"/350 – 600 mm) groove diameter specifications.
- Tapes are notched on the lead end to allow proper overlap within the groove for more accurate measurement.
- The Go/No-Go side of the tape is not intended for use on sizes 76.1; 139.7; 165.1; 165.2; 216.3; 267.4; and 318.5 mm steel or stainless steel pipe sizes. For cast or ductile iron pipe sizes (up to 20"/500 mm), copper tube sizes, and the steel and stainless steel pipe sizes listed above, use the side of the tape marked in 0.01" increments.
- The Go/No-Go pipe tape is a quick reference guide only. To ensure proper grooving dimensions, always refer to the I-100 Victaulic Field Installation Handbook or to the latest groove specifications publications located on www.victaulic.com.
- AGS/Go-No-Go pocket-sized steel tapes are available for taking circumferential measurements.
- Metric versions also available.

Pipe Preparation

Grooving Times

Time for pipe preparation obviously depends on widely varied factors including productivity, location, type, hardness, and wall thickness of pipe. As a gauge for typical grooving times, the following chart was prepared to include grooving time with pipe in position and tool properly set for the size and depth of groove. Times will be extended when going from one size to another for roll changes, depth stop setting, trial grooving and other minor adjustments incidental to changing pipe sizes or initial set-up time prior to the first production groove.

PIPE PREPARATION

APPROXIMATE GROOVING TIME IN MINUTES – STEEL PIPE *

Size Nominal Size Inches mm	Roll Groovers – Powered							Cut Groovers			
	226	272SFS	270FSD	268	416FSD	414MC	436MC	Vic-Groover		Vic-Adjustable	
								Power	Hand	VG28GD Power	VG824 Power
3/4 20	0.5 #	—	0.2	0.2	—	—	—	0.5	1.5	—	—
1 25	0.6 #	—	0.2	0.2	—	—	—	0.5	1.5	—	—
1 1/4 32	0.7 #@	—	0.2	0.2	—	—	—	0.7	2.0	—	—
1 1/2 40	0.8 #@	—	0.2	0.2	—	—	—	0.7	2.5	—	—
2 50	1.0 @≠	0.3	0.3	0.3	0.3	0.2	—	1.0	3.0	1.0	—
2 1/2 65	1.3 @≠	0.3	0.3	0.3	0.3	0.2	—	1.2	3.8	1.3	—
76.1 mm	1.3 @≠	0.3	0.3	0.3	0.3	0.2	—	1.2	3.8	1.3	—
3 80	1.4 @≠	0.4	0.4	0.4	0.4	0.2	—	1.4	4.5	1.5	—
3 1/2 90	1.4 @≠	0.4	0.4	0.4	0.4	0.2	—	1.7	5.5	2.0	—
4 100	1.5 @≠	0.5	0.4	0.5	0.5	0.2	0.2	1.9	7.0	2.5	—
108.1 mm	1.5 @≠	0.5	0.4	0.5	0.5	0.2	0.2	1.9	7.0	2.5	—
4 1/2	1.5 @≠	0.8	0.6	0.6	0.6	0.2	0.2	2.3	8.0	2.8	—
5 125	1.6 @≠	1.0	0.8	0.8	0.8	0.2	0.3	2.5	9.0	3.5	—
133.0 mm	1.6 @≠	1.0	0.8	0.8	0.8	0.2	0.3	2.5	9.0	3.5	—
139.7 mm	1.6 @≠	1.0	0.8	0.8	0.8	0.2	0.3	2.5	9.0	3.5	—
6 150	1.8 @≠	1.5	1.2	0.8	1.0	0.3	0.5	3.0	10.0	4.5	—
159.0 mm	1.8 @≠	1.5	1.2	0.8	1.0	0.3	0.5	3.0	10.0	4.5	—
165.1 mm	1.8 @≠	1.5	1.2	0.8	1.0	0.3	0.5	3.0	10.0	4.5	—
8 200	—	1.7	1.5	0.9	1.7	0.4	0.8	4.0	15.0	5.0	5.0
10 250	—	2.0	1.8	1.5	2.5	0.6	1.1	—	—	—	8.0
12 300	—	2.5	2.3	1.8	3.5	0.7	1.4	—	—	—	10.0
14 350	—	—	—	—	7.4+	3.6+	3.6+	—	—	—	12.0
16 400	—	—	—	—	8.0+	4.0+	4.0+	—	—	—	16.0
18 450	—	—	—	—	—	—	4.6+	—	—	—	20.0
20 500	—	—	—	—	—	—	5.0+	—	—	—	23.0
24 600	—	—	—	—	—	—	6.0+	—	—	—	30.0
30† 750	—	—	—	—	—	—	3.8	—	—	—	—
36† 900	—	—	—	—	—	—	—	—	—	—	—

VE226B

@ VE226S

≠ VE226M

* For roll groovers the times apply to the thickest pipe wall for which the tool is rated. See tool capacities. For cut groovers, the times apply to standard wall steel pipe. For other materials and thicknesses contact Victaulic for details.

+ Times for roll grooving Advanced Groove System (AGS) pipe.

† For 26"/650 mm, 28"/700 mm, 32"/800 mm and 42"/1050 mm grooving times contact Victaulic.

Pipe Preparation

Standard Pipe Wall Thickness

STANDARD PIPE WALL THICKNESS (ANSI B 36.10 AND B 36.19 FOR STAINLESS STEEL PIPE)

Size		Pipe Wall Thickness								
Nominal Size Inches mm	Actual Outside Dia. Inches mm	Schedule 5S Inches mm	Schedule 5 Inches mm	Schedule 10S Inches mm	Schedule 10 Inches mm	Schedule 20 Inches mm	Schedule 30 Inches mm	Schedule 40 Inches mm	Schedule Std. Inches mm	Schedule 80 Inches mm
¾ 20	1.050 26.9	0.065 1.65	0.065 1.65	0.083 2.11	—	—	—	0.113 2.87	0.113 2.87	0.154 3.91
1 25	1.315 33.7	0.065 1.65	0.065 1.65	0.109 2.77	—	—	—	0.133 3.38	0.133 3.38	0.179 4.55
1 ¼ 32	1.660 42.4	0.065 1.65	0.065 1.65	0.109 2.77	—	—	—	0.140 3.56	0.140 3.56	0.191 4.85
1 ½ 40	1.900 48.3	0.065 1.65	0.065 1.65	0.109 2.77	—	—	—	0.145 3.68	0.145 3.68	0.200 5.08
2 50	2.375 60.3	0.065 1.65	0.065 1.65	0.109 2.77	—	—	—	0.154 3.91	0.154 3.91	0.218 5.54
2 ½ 65	2.875 73.0	0.083 2.11	0.083 2.11	0.120 3.05	—	—	—	0.203 5.16	0.203 5.16	0.276 7.01
76.1 mm	3.000 76.1	0.083 2.11	0.083 2.11	0.120 3.05	—	—	—	0.216 5.49	0.216 5.49	0.300 7.62
3 80	3.500 88.9	0.083 2.11	0.083 2.11	0.120 3.05	—	—	—	0.216 5.49	0.216 5.49	0.300 7.62
3 ½ 90	4.000 101.6	0.083 2.11	0.083 2.11	0.120 3.05	—	—	—	0.226 5.74	0.226 5.74	0.318 8.08
4 100	4.500 114.3	0.083 2.11	0.083 2.11	0.120 3.05	—	—	—	0.237 6.02	0.237 6.02	0.337 8.56
108.1 mm	4.250 108.1	0.083 2.11	0.083 2.11	0.120 3.05	—	—	—	0.237 6.02	0.237 6.02	0.337 8.56
4 ½	5.000 127.0	0.083 2.11	0.083 2.11	0.120 3.05	—	—	—	0.237 6.02	0.237 6.02	0.337 8.56
5 125	5.563 141.3	0.109 2.77	0.109 2.77	0.134 3.40	—	—	—	0.258 6.55	0.258 6.55	0.375 9.53
133.0 mm	5.250 133.0	0.083 2.11	0.083 2.11	0.120 3.05	—	—	—	0.237 6.02	0.237 6.02	0.337 8.56
139.7 mm	5.500 139.7	0.109 2.77	0.109 2.77	0.134 3.40	—	—	—	0.258 6.55	0.258 6.55	0.375 9.53
6 150	6.625 168.3	0.109 2.77	0.109 2.77	0.134 3.40	—	—	—	0.280 7.11	0.280 7.11	0.432 10.97
159.0 mm	6.250 159.0	0.109 2.77	0.109 2.77	0.134 3.40	—	—	—	0.280 7.11	0.280 7.11	0.432 10.97
165.1 mm	6.500 165.1	0.109 2.77	0.109 2.77	0.134 3.40	—	—	—	0.280 7.11	0.280 7.11	0.432 10.97
8 200	8.625 219.1	0.109 2.77	0.109 2.77	0.148 3.76	—	0.250 6.35	0.277 7.04	0.322 8.18	0.322 8.18	0.500 12.70
10 250	10.750 273.0	0.134 3.40	0.134 3.40	0.165 4.19	—	0.250 6.35	0.307 7.80	0.365 9.27	0.365 9.27	0.594 15.09
12 300	12.750 323.8	0.156 3.96	0.156 3.96	0.180 4.57	—	0.250 6.35	0.330 8.38	0.406 10.31	0.375 9.53	0.688 17.48
14 350	14.000 355.6	0.156 3.96	—	0.188 4.78	0.250 6.35	0.312 7.92	0.375 9.53	0.438 11.13	0.375 9.53	0.750 19.05
16 400	16.000 406.4	0.165 4.19	—	0.188 4.78	0.250 6.35	0.312 7.92	0.375 9.53	0.500 12.70	0.375 9.53	0.844 21.44
18 450	18.000 457.0	0.165 4.19	—	0.188 4.78	0.250 6.35	0.312 7.92	0.438 11.13	0.562 14.27	0.375 9.53	0.938 23.83
20 500	20.000 508.0	0.188 4.78	—	0.218 5.54	0.250 6.35	0.375 9.53	0.500 12.70	0.594 15.09	0.375 9.53	1.031 26.19
24 600	24.000 610.0	0.218 5.54	—	0.250 6.35	0.250 6.35	0.375 9.53	0.562 14.27	0.688 17.48	0.375 9.53	1.219 30.96
26 650	26.000 660.4	—	—	—	0.312 7.92	0.500 12.70	—	—	0.375 9.53	—
28 700	28.000 711.0	—	—	—	0.312 7.92	0.500 12.70	0.625 15.88	—	0.375 9.53	—
30 750	30.000 762.0	0.250 6.35	—	0.312 7.92	0.312 7.92	0.500 12.70	0.625 15.88	—	0.375 9.53	—
32 800	32.000 813.0	—	—	—	0.312 7.92	0.500 12.70	0.625 15.88	0.688 17.48	0.375 9.53	—
36 900	36.000 914.0	—	—	—	0.312 7.92	0.500 12.70	0.625 15.88	0.750 19.05	0.375 9.53	—
42 1050	42.000 1067.0	—	—	—	—	—	—	—	0.375 9.53	—

Pipe Preparation

Groove Dimensions

ROLL GROOVE SPECIFICATIONS NOTES

For Complete Information Request Publication **25.01**

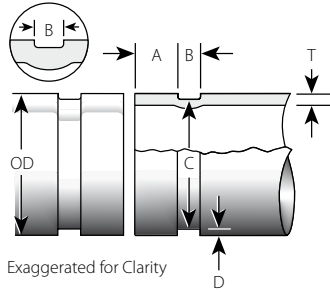

STANDARD ROLL GROOVE SPECIFICATIONS – STEEL AND OTHER IPS PIPE@†

1 Nominal Size Inches mm	2 Dimensions – Inches/mm									
	3 Pipe Outside Diameter O.D.			4 A Gasket Seat ± 0.03 ± 0.76	5 B Grv. Width ± 0.03 ± 0.76	6 Groove Diameter C		7 D Groove Depth ref.	8 T Minimum Allow. Wall Thk.	9 Maximum Allow. Flare Diameter
	Basic	Tolerance				Basic	Tol. +0.000 +0.00			
3/4 20	1.050 26.9	+0.010 +0.25	-0.010 -0.25	0.625 15.88	0.281 7.14	0.938 23.83	-0.015 -0.38	0.056 1.42	0.065 1.65	1.15 29.2
1 25	1.315 33.7	+0.013 +0.33	-0.013 -0.33	0.625 15.88	0.281 7.14	1.190 30.23	-0.015 -0.38	0.063 1.60	0.065 1.65	1.43 36.3
1 1/4 32	1.660 42.4	+0.016 +0.41	-0.016 -0.41	0.625 15.88	0.281 7.14	1.535 38.99	-0.015 -0.38	0.063 1.60	0.065 1.65	1.77 45.0
1 1/2 40	1.900 48.3	+0.019 +0.48	-0.019 -0.48	0.625 15.88	0.281 7.14	1.775 45.09	-0.015 -0.38	0.063 1.60	0.065 1.65	2.01 51.1
2 50	2.375 60.3	+0.024 +0.61	-0.024 -0.61	0.625 15.88	0.344 8.74	2.250 57.15	-0.015 -0.38	0.063 1.60	0.065 1.65	2.48 63.0
2 1/2 65	2.875 73.0	+0.029 +0.74	-0.029 -0.74	0.625 15.88	0.344 8.74	2.720 69.09	-0.018 -0.46	0.078 1.98	0.083 2.11	2.98 75.7
76.1 mm	3.000 76.1	+0.030 +0.76	-0.030 -0.76	0.625 15.88	0.344 8.74	2.845 72.26	-0.018 -0.46	0.078 1.98	0.083 2.11	3.10 78.7
3 80	3.500 88.9	+0.035 +0.89	-0.031 -0.79	0.625 15.88	0.344 8.74	3.344 84.94	-0.018 -0.46	0.078 1.98	0.083 2.11	3.60 91.4
3 1/2 90	4.000 101.6	+0.040 +1.02	-0.031 -0.79	0.625 15.88	0.344 8.74	3.834 97.38	-0.020 -0.51	0.083 2.11	0.083 2.11	4.10 104.1
4 100	4.500 114.3	+0.045 +1.14	-0.031 -0.79	0.625 15.88	0.344 8.74	4.334 110.08	-0.020 -0.51	0.083 2.11	0.083 2.11	4.60 116.8
108.0 mm	4.250 108.0	+0.043 +1.09	-0.031 -0.79	0.625 15.88	0.344 8.74	4.084 103.73	-0.020 -0.51	0.083 2.11	0.083 2.11	4.35 110.5
4 1/2 120	5.000 127.0	+0.050 +1.27	-0.031 -0.79	0.625 15.88	0.344 8.74	4.834 122.78	-0.020 -0.51	0.083 2.11	0.095 2.41	5.10 129.5
5 125	5.563 141.3	+0.056 +1.42	-0.031 -0.79	0.625 15.88	0.344 8.74	5.395 137.03	-0.022 -0.56	0.084 2.13	0.109 2.77	5.66 143.8
133.0 mm	5.250 133.0	+0.053 +1.35	-0.031 -0.79	0.625 15.88	0.344 8.74	5.084 129.13	-0.020 -0.51	0.083 2.11	0.109 2.77	5.35 135.9
139.7 mm	5.500 139.7	+0.056 +1.42	-0.031 -0.79	0.625 15.88	0.344 8.74	5.334 135.48	-0.020 -0.51	0.083 2.11	0.109 2.77	5.60 142.2
6 150	6.625 168.3	+0.063 +1.60	-0.031 -0.79	0.625 15.88	0.344 8.74	6.455 163.96	-0.022 0.56	0.085 2.16	0.109 2.77	6.73 170.9
152.4 mm	6.000 152.4	+0.056 +1.42	-0.031 -0.79	0.625 15.88	0.344 8.74	5.830 148.08	-0.022 -0.56	0.109 2.80	0.109 2.77	6.10 154.9
159.0 mm	6.250 159.0	+0.063 +1.60	-0.031 -0.79	0.625 15.88	0.344 8.74	6.032 153.21	-0.030 -0.46	0.109 2.80	0.109 2.77	6.35 161.3
165.1 mm	6.500 165.1	+0.063 +1.60	-0.031 -0.79	0.625 15.88	0.344 8.74	6.330 160.78	-0.022 -0.56	0.085 2.16	0.109 2.77	6.60 167.6
8 200	8.625 219.1	+0.063 +1.60	-0.031 -0.79	0.750 19.05	0.469 11.91	8.441 214.40	-0.025 -0.64	0.092 2.34	0.109 2.77	8.80 223.5
203.2 mm	8.000 203.2	+0.063 +1.60	-0.031 -0.79	0.750 19.05	0.469 11.91	7.816 198.53	-0.025 -0.64	0.092 2.34	0.109 2.77	8.17 207.5
10 250	10.750 273.0	+0.063 +1.60	-0.031 -0.79	0.750 19.05	0.469 11.91	10.562 268.28	-0.027 -0.69	0.094 2.39	0.134 3.40	10.92 277.4
254.0 mm	10.000 254.0	+0.063 +1.60	-0.031 -0.79	0.750 19.05	0.469 11.91	9.812 249.23	-0.027 -0.69	0.094 2.39	0.134 3.40	10.17 258.3
12 300	12.750 323.9	+0.063 +1.60	-0.031 -0.79	0.750 19.05	0.469 11.91	12.531 318.29	-0.030 -0.76	0.109 2.77	0.156 3.96	12.92 328.2
304.8 mm	12.000 304.8	+0.063 +1.60	-0.031 -0.79	0.750 19.05	0.469 11.91	11.781 299.24	-0.030 -0.76	0.109 2.77	0.156 3.96	12.17 309.1
14 – 24 350 – 600	AGS™ See AGS Grooving Chart, pg. 17-19									

@ Always refer to the I-100 handbook for current grooving specifications.

† On roll grooved pipe, Allowable Pipe End Separation and Deflection from center line will be 1/2 values listed for cut grooved pipe.

For non-AGS grooves in this size refer to the I-100 pocket handbook for current grooving specifications.

IMPORTANT NOTES:

For roll grooving pipe from 24–48"/600–1200 mm contact Victaulic.

Coatings applied to the interior surfaces, including bolt pad mating surfaces, of our grooved and bolted plain end couplings should not exceed 0.010"/0.25 mm. Also, the coating thickness applied to the gasket seating surface and within the groove on the pipe exterior should not exceed 0.010"/0.25 mm.

GROOVE DIMENSION NOTES: SEE PG. 17-18

Pipe Preparation

Groove Dimensions

ROLL GROOVE SPECIFICATIONS NOTES

For Complete Information Request Publication 25.01

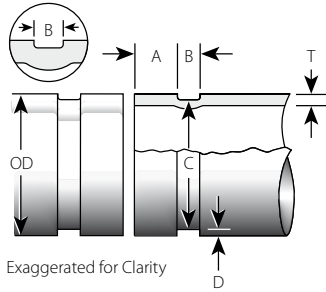

LARGE DIAMETER ROLL GROOVE SPECIFICATIONS@

1 Nominal Size Inches mm	2 Dimensions – Inches/mm											
	3 Pipe Outside Diameter O.D.			4 A Gasket Seat + 0.03 - 0.06 + 0.8 - 1.5	5 B Grv. Width ± 0.03 ± 0.76		6 C Groove Diameter		7 Groove Depth D ref.	8 T Min. Allow. Wall Thickness		9 Max. Allow. Flare Dia.
	Basic	+ Tolerance	-		Roll Groove	Cut Groove	Basic	Tol. +0.000 +0.00		Roll Groove	Cut Groove	
26 O.D. 650	26.00 660.4	+0.093 +2.36	-0.031 -0.79	1.75 45.45	0.625 15.88	0.625 15.88	25.50 647.7	-0.063 -1.60	0.250 6.35	0.250 6.35	0.625 15.88	26.20 665.5
28 O.D. 700	28.00 711.0	+0.093 +2.36	-0.031 -0.79	1.75 45.45	0.625 15.88	0.625 15.88	27.50 698.50	-0.063 -1.60	0.250 6.35	0.250 6.35	0.625 15.88	28.20 716.3
30 O.D. 750	30.00 762.0	+0.093 +2.36	-0.031 -0.79	1.75 45.45	0.625 15.88	0.625 15.88	29.50 749.30	-0.063 -1.60	0.250 6.35	0.250 6.35	0.625 15.88	30.20 767.1
32 O.D. 800	32.00 813.0	+0.093 +2.36	-0.031 -0.79	1.75 45.45	0.625 15.88	0.625 15.88	31.50 800.10	-0.063 -1.60	0.250 6.35	0.250 6.35	0.625 15.88	32.20 817.9
36 O.D. 900	36.00 914.0	+0.093 +2.36	-0.031 -0.79	1.75 45.45	0.625 15.88	0.625 15.88	35.50 901.70	-0.063 -1.60	0.250 6.35	0.250 6.35	0.625 15.88	36.20 919.5
42 O.D. 1050	42.00 1067.0	+0.093 +2.36	-0.031 -0.79	2.00 50.80	0.625 15.88	0.625 15.88	41.50 1054.10	-0.063 -1.60	0.250 6.35	0.250 6.35	0.625 15.88	42.20 1071.8

@ Always refer to the I-100 handbook for current grooving specifications.

IMPORTANT NOTES:

For roll grooving pipe from 24–48"/600–1200 mm contact Victaulic.

Coatings applied to the interior surfaces, including bolt pad mating surfaces, of our grooved and bolted plain end couplings should not exceed 0.010"/0.25 mm. Also, the coating thickness applied to the gasket seating surface and within the groove on the pipe exterior should not exceed 0.010"/0.25 mm.

GROOVE DIMENSION NOTES:

Column 1: Nominal IPS Pipe Size

Column 2: IPS Pipe Outside Diameter

The average pipe outside diameter must not vary from the specifications listed in the tables on the following pages. Maximum allowable pipe ovality should not vary by more than 1%. Greater variations between the major and minor diameters will result in difficult coupling assembly. For IPS pipe, the maximum allowable tolerance from square-cut pipe ends is 0.030"/0.8 mm for ¾–3 ½"/20–90 mm sizes; 0.045"/1.1 mm for 4–6"/100–150 mm sizes; and 0.060"/1.5 mm for 8"/200 mm and larger sizes. This is measured from the true square line. Any internal and external weld beads or seams must be ground flush to the pipe surface. The inside diameter of the pipe end must be cleaned to remove coarse scale, dirt, and other foreign material that might interfere with or damage grooving rolls.

Column 3: Gasket Seat "A" Dimension

The "A" dimension, or the distance from the pipe end to the groove, identifies the gasket seating area. This area must be free from indentations, projections (including weld seams), and roll marks from the pipe end to the groove to ensure a leak-tight seal for the gasket. All oil, grease, and dirt must be removed.

Column 4: Groove Width "B" Dimension

The "B" dimension, or groove width, controls expansion, contraction, and angular deflection of flexible couplings by the distance it is located from the pipe and its width in relation to the coupling housings' "key" width.

Column 5: Groove Outside Diameter "C" Dimension

The "C" dimension is the proper diameter at the base of the groove. This dimension must be within the diameter's tolerance and concentric with the OD for proper coupling fit. The groove must be of uniform depth for the entire pipe circumference.

Column 6: Groove Depth "D" Dimension

The "D" dimension is the normal depth of the groove and is a reference for a "trial groove" only. Variations in pipe OD affect this dimension and must be altered, if necessary, to keep the "C" dimension within tolerance. This groove must conform to the "C" dimension described above.

Column 7: Minimum Allowable Wall Thickness "T" Dimension

The "T" dimension is the lightest grade (minimum, nominal wall thickness) of pipe that is suitable for cut or roll grooving. Pipe that is less than the minimum, nominal wall thickness for cut grooving may be roll grooved or adapted for Victaulic couplings by using Vic-Ring adapters. Vic-Ring adapters can be used in the following situations (contact Victaulic for details):

- When the pipe is less than the minimum, nominal wall thickness suitable for roll grooving
- When the pipe outside diameter is too large to roll or cut groove
- When the pipe is used in abrasive services

Column 8: Maximum Allowable Pipe-End Flare Diameter "F" Dimension (Standard Roll Groove Only)

Maximum allowable pipe-end flare diameter is measured at the extreme pipe-end diameter.

Pipe Preparation

Groove Dimensions

ADVANCED GROOVE SYSTEM (AGS) ROLL GROOVE SPECIFICATIONS NOTES

For Complete Information Request Publication **25.09**

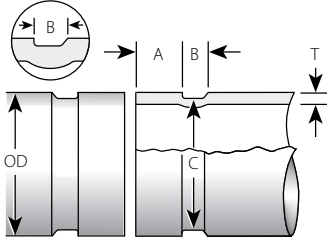

Exaggerated for Clarity

WARNING

- Victaulic AGS products **MUST NOT** be used on pipe that is prepared to standard groove dimensions.
- When grooving pipe for use with AGS products, Victaulic roll grooving tools must be equipped with special Victaulic AGS roll sets made specifically for use with standard-weight pipe.
- It is critical to measure the Groove Diameter “C” dimension, along with the Gasket Seat “A” dimension and the Flare Diameter “F” dimension. These measurements must be within the specifications listed in this table above for proper joint performance.

Failure to follow these instructions could cause joint failure, resulting in serious personal injury and/or property damage.

STANDARD ADVANCED GROOVE SYSTEM (AGS) ROLL GROOVE SPECIFICATIONS – CARBON STEEL

1	2		3	Dimensions – Inches/mm			7	
	Pipe Outside Diameter O.D.			A Gasket Seat + 0.031/-0.063 + 0.79/-1.60	B Grv. Width ref.	C Groove Diameter		
	Maximum	Minimum				Maximum		Minimum
14 355.6	14.094 358.0	13.969 354.8	0.375 9.5	1.500 38.1	0.455 11.56	13.500 342.9	13.455 341.8	14.23 361.4
16 406.4	16.094 408.8	15.969 405.6	0.375 9.5	1.500 38.1	0.455 11.56	15.500 393.7	15.455 392.6	16.23 412.2
18 457.0	18.094 459.6	17.969 456.4	0.375 9.5	1.500 38.1	0.455 11.56	17.500 444.5	17.455 443.4	18.23 463.0
20 508.0	20.094 510.4	19.969 507.2	0.375 9.5	1.500 38.1	0.455 11.56	19.500 493.3	19.455 492.2	20.23 513.8
24 610.0	24.094 612.0	23.969 608.8	0.375 9.5	1.500 38.1	0.455 11.56	23.500 596.9	23.455 595.8	24.23 615.4

IMPORTANT NOTES:

Roll grooving removes no metal, cold forming a groove by the action of an upper male roll being forced into pipe as it is rotated by a lower female drive roll.

Roll grooving pipe to AGS specifications enlarges the pipe length by approximately 1/8"/3.2 mm for each groove. For a pipe length with an AGS roll groove at each end, the pipe length will grow approximately 1/4"/6.4 mm total. Therefore, the cut length should be adjusted to accommodate this growth.

EXAMPLE: If you need a 24"/610 mm length of pipe that will contain an AGS roll groove at each end, cut the pipe to a length of 23 3/4"/603 mm to allow for this growth.

Coatings applied to the interior surfaces, including bolt pad mating surfaces, of our grooved end couplings should not exceed 0.010"/0.25 mm. Also, the coating thickness applied to the gasket seating surface and within the groove on the pipe exterior should not exceed 0.010"/0.25 mm.

GROOVE DIMENSION NOTES:

Column 1: Nominal IPS Pipe Size (ANSI B36.10); Basic Metric pipe size (ISO 4200)

Column 2: Outside Diameter

The outside diameter of roll grooved pipe shall not vary more than the limits listed (API 5L end tolerance). The maximum allowable tolerance from square cut ends is 0.063"/1.5 mm measured from a true square line.

Column 3: Minimum Nominal Wall Thickness

This is the minimum nominal wall thickness which may be roll grooved.

Column 4: Gasket Seat

The pipe surface shall be free from indentations, roll marks, and projections from the end of the pipe to the groove, to provide a leak-tight seat for the gasket. All loose paint, scale, dirt, chips, grease, and rust must be removed. Beveled carbon steel pipe may be used provided the wall thickness is standard wall (.375"/9.5 mm) and the bevel meets ASTM A53 and/or API 5L (30° +5°/-0°). Gasket seat "A" is measured from the end of the pipe.

Column 5: Groove Width

Bottom of groove must be free of loose dirt, chips, rust and scale that may interfere with proper coupling assembly. Corners at bottom of groove must be radiused R .09 (R 2.3). Only Victaulic roll grooving tools may be used to groove pipe. Groove width and corner radii will be attained with properly maintained Victaulic tools.

Column 6: Groove Diameter

The groove must be of uniform depth for the entire pipe circumference. Groove must be maintained within the "C" diameter limits listed. Standard weight carbon steel pipe shall be prepared with Victaulic "RW" rolls.

Column 7: Maximum Allowable Pipe End Flare Diameter

Dimension measured at the most extreme pipe end diameter, square cut or beveled.

Pipe Preparation

Groove Dimensions

COPPER TUBING ROLL GROOVE SPECIFICATIONS NOTES

For Complete Information
Request Publication 25.06

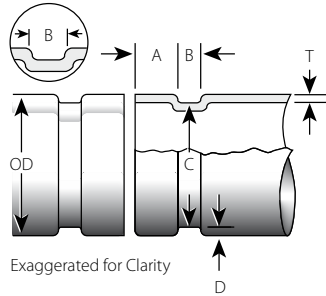

COPPER TUBING ROLL GROOVE SPECIFICATIONS@

1 Nominal Size Inches mm	2 Actual Outer Diameter		Dimensions – Inches/mm					7 T Minimum Allow. Wall Thick.	8 Maximum Allow. Flare Diameter
	Basic Inches mm	Tolerance Inches mm	A Gasket Seat ± 0.03 ± 0.76	B Grv. Width +0.03/-0.00 -0.76/-0.00	C Grv. Diameter +0/-0.020 +0/-0.5	D Groove Depth ref.			
2 50	2.125 54.0	±0.002 ±0.05	0.610 15.5	0.300 7.6	2.209 51.5	0.048 1.2	DWV	2.220 56.4	
2½ 65	2.625 66.7	±0.002 ±0.05	0.610 15.5	0.300 7.6	2.525 64.1	0.050 1.2	0.065 (1.7)	2.720 69.1	
3 80	3.125 79.4	±0.002 ±0.05	0.610 15.5	0.300 7.6	3.025 76.8	0.050 1.2	DWV	3.220 81.8	
4 100	4.125 104.8	±0.002 ±0.05	0.610 15.5	0.300 7.6	4.019 102.1	0.053 1.4	DWV	4.220 107.2	
5 125	5.125 130.2	±0.002 ±0.05	0.610 15.5	0.300 7.6	4.999 127.0	0.053 1.4	DWV	5.220 132.6	
6 150	6.125 155.6	±0.002 ±0.05	0.610 15.5	0.300 7.6	5.999 152.3	0.063 1.6	DWV	6.220 158.0	
8 200	8.125 206.4	±0.002/-0.004 ±0.05/-0.10	0.610 15.5	0.300 7.6	7.959 202.2	0.083 2.1	DWV	8.220 208.8	

@ Always refer to the I-600 handbook for current grooving specifications.

GROOVE DIMENSION NOTES:

Column 1: Nominal ASTM B-88 drawn copper tubing size as indicated in the chart heading

Column 2: Outside Diameter

The outside diameter of roll grooved tubing shall not vary more than the tolerance listed. The maximum allowable tolerance from square cut ends is 0.030"/0.8 mm for 2–3"/50–80 mm; 0.045"/1.1 mm for 4–6"/100–150 mm, measured from true square line.

Column 3: Gasket Seat

The tubing surface shall be free from indentations, roll marks, and projections from the end of the tubing to the groove, to provide a leak-tight seat for the gasket. All loose scales, dirt, chips and grease must be removed.

Column 4: Groove Width

Bottom of groove to be free of loose dirt, chips and scale that may interfere with proper coupling assembly.

Column 5: Groove Outside Diameter

The groove must be uniform depth for the entire tubing circumference. Groove must be maintained within the "C" diameter tolerance listed.

Column 6: Groove Depth

For reference only. Groove must conform to the groove diameter "C" listed.

Column 7: Minimum Allowable Wall Thickness "T" Dimension

ASTM B-306 drain waste and vent (DWV) is minimum wall thickness copper tubing which may be roll grooved.

Column 8: Maximum Allowable End Flare Diameter

Measured at the most extreme tubing end diameter.

Pipe Preparation

Groove Dimensions

STANDARD CUT GROOVE SPECIFICATIONS NOTES

For Complete Information Request Publication 25.01

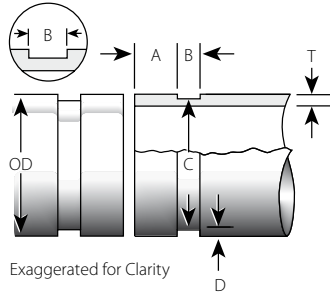

GROOVE DIMENSION NOTES:

Column 1: Nominal IPS Pipe Dize

Column 2: IPS Outside Diameter

The outside diameter of cut grooved pipe shall not vary more than the tolerance listed. For IPS pipe the maximum allowable tolerance from square cut ends to 0.030"/0.76 mm for 3/4 - 3 1/2"/20 - 90 mm; 0.045"/1.14 mm for 4 - 6"/100 - 150 mm; and 0.060"/1.5 mm for sizes 8"/200 mm O.D. and above measured from true square line.

Column 3: Gasket Seat

The pipe surface shall be free from indentations, roll marks, and projections from the end of the pipe to the groove, to provide a leak-tight seal for the gasket. All loose paint, scale, dirt, chips, grease and rust must be removed. It continues to be Victaulic's first recommendation that pipe be square cut. When using beveled pipe contact Victaulic for details. Square cut pipe must be used with FlushSeal and EndSeal gaskets. Gasket seat "A" is measured from the end of the pipe.

Column 4: Groove Width

The bottom of groove to be free of loose dirt, chips, rust and scale that may interfere with proper coupling assembly. Maximum permissible radius at bottom of groove is .015"/.38 mm.

Column 5: Groove Outside Diameter

The groove must be of uniform depth for the entire pipe circumference. Groove must be maintained within the "C" diameter tolerance listed.

Column 6: Groove Depth

For reference only. Groove must conform to the groove diameter "C" listed.

Column 7: Minimum Allowable Wall Thickness

This is the minimum wall thickness which may be cut grooved.

STANDARD CUT GROOVE SPECIFICATIONS - STEEL AND OTHER IPS PIPE @

1 Nominal Size Inches mm	2 Dimensions - Inches/mm								
	Pipe Outside Diameter O.D.			A Gasket Seat ± 0.03 ± 0.76	B Grv. Width ± 0.03 ± 0.76	C Groove Diameter		D Groove Depth ref.	T Minimum Allow. Wall Thick.
	Basic	Tolerance + -				Basic	Tol. +0.000 +0.00		
3/4 20	1.050 26.9	+0.010 +0.25	-0.010 -0.25	0.625 15.88	0.313 7.95	0.938 23.83	-0.015 -0.38	0.056 1.42	0.113 2.87
1 25	1.315 33.7	+0.013 +0.33	-0.013 -0.33	0.625 15.88	0.313 7.95	1.190 30.23	-0.015 -0.38	0.063 1.60	0.133 3.38
1 1/4 32	1.660 42.4	+0.016 +0.41	-0.016 -0.41	0.625 15.88	0.313 7.95	1.535 38.99	-0.015 -0.38	0.063 1.60	0.140 3.56
1 1/2 40	1.900 48.3	+0.019 +0.48	-0.019 -0.48	0.625 15.88	0.313 7.95	1.775 45.09	-0.015 -0.38	0.063 1.60	0.145 3.68
2 50	2.375 60.3	+0.024 +0.61	-0.024 -0.61	0.625 15.88	0.313 7.95	2.250 57.15	-0.015 -0.38	0.063 1.60	0.154 3.91
2 1/2 65	2.875 73.0	+0.029 +0.74	-0.029 -0.74	0.625 15.88	0.313 7.95	2.720 69.09	-0.018 -0.46	0.078 1.98	0.188 4.76
76.1 mm	3.000 76.1	+0.030 +0.76	-0.030 -0.76	0.625 15.88	0.313 7.95	2.845 72.26	-0.018 -0.46	0.078 1.98	0.188 4.78
3 80	3.500 88.9	+0.035 +0.89	-0.031 -0.79	0.625 15.88	0.313 7.95	3.344 84.94	-0.018 -0.46	0.078 1.98	0.188 4.78
3 1/2 90	4.000 101.6	+0.040 +1.02	-0.031 -0.79	0.625 15.88	0.313 7.95	3.834 97.38	-0.020 -0.51	0.083 2.11	0.188 4.78
4 100	4.500 114.3	+0.045 +1.14	-0.031 -0.79	0.625 15.88	0.375 9.53	4.334 110.08	-0.020 -0.51	0.083 2.11	0.203 5.16
4 1/2 120	5.000 127.0	+0.050 +1.27	-0.031 -0.79	0.625 15.88	0.375 9.53	4.834 122.78	-0.020 -0.51	0.083 2.11	0.203 5.16
5 125	5.563 141.3	+0.056 +1.42	-0.031 -0.79	0.625 15.88	0.375 9.53	5.395 137.03	-0.020 -0.51	0.084 2.13	0.203 5.16
139.7 mm	5.500 139.7	+0.056 +1.42	-0.031 -0.79	0.625 15.88	0.375 9.53	5.334 135.48	-0.020 -0.51	0.083 2.11	0.203 5.16
6 150	6.625 168.3	+0.063 +1.60	-0.031 -0.79	0.625 15.88	0.375 9.53	6.455 163.96	-0.022 0.56	0.085 2.16	0.219 5.56
152.4 mm	6.000 152.4	+0.056 +1.42	-0.031 -0.79	0.625 15.88	0.375 9.53	5.830 148.08	-0.022 -0.56	0.085 2.16	0.219 5.56
165.1 mm	6.500 165.1	+0.063 +1.60	-0.031 -0.79	0.625 15.88	0.375 9.53	6.330 160.78	-0.022 -0.56	0.085 2.16	0.219 5.56
8 200	8.625 219.1	+0.063 +1.60	-0.031 -0.79	0.750 19.05	0.438 11.13	8.441 214.40	-0.025 -0.64	0.092 2.34	0.238 6.05
203.2 mm	8.000 203.2	+0.063 +1.60	-0.031 -0.79	0.750 19.05	0.438 11.13	7.816 198.53	-0.022 -0.56	0.092 2.34	0.238 6.05
10 250	10.750 273.0	+0.063 +1.60	-0.031 -0.79	0.750 19.05	0.500 12.70	10.562 268.28	-0.027 -0.69	0.094 2.39	0.250 6.35
254.0 mm	10.000 254.0	+0.063 +1.60	-0.031 -0.79	0.750 19.05	0.500 12.70	9.812 249.23	-0.025 -0.64	0.094 2.39	0.250 6.35
12 300	12.750 323.9	+0.063 +1.60	-0.031 -0.79	0.750 19.05	0.500 12.70	12.531 318.29	-0.030 -0.76	0.109 2.77	0.279 7.09
304.8 mm	12.000 304.8	+0.063 +1.60	-0.031 -0.79	0.750 19.05	0.500 12.70	11.781 299.24	-0.027 -0.69	0.109 2.77	0.279 7.09
14 350	14.000 355.6	+0.063 +1.60	-0.031 -0.79	0.938 23.83	0.500 12.70	13.781 350.04	-0.030 -0.76	0.109 2.77	0.281 7.14
15 375	15.000 381.0	+0.063 +1.60	-0.031 -0.79	0.938 23.83	0.500 12.70	14.781 375.44	-0.030 -0.76	0.109 2.77	0.312 7.92
16 400	16.000 406.4	+0.063 +1.60	-0.031 -0.79	0.938 23.83	0.500 12.70	15.781 400.84	-0.030 -0.76	0.109 2.77	0.312 7.92
18 450	18.000 457.2	+0.063 +1.60	-0.031 -0.79	1.000 25.40	0.500 12.70	17.781 451.64	-0.030 -0.76	0.109 2.77	0.312 7.92
20 500	20.000 508.0	+0.063 +1.60	-0.031 -0.79	1.000 25.40	0.500 12.70	19.781 502.44	-0.030 -0.76	0.109 2.77	0.312 7.92
22 550	22.000 559.0	+0.063 +1.60	-0.031 -0.79	1.000 25.40	0.563* 14.30	21.656 550.06	-0.030 -0.76	0.109 2.77	0.312 7.92
24 600	24.000 610.0	+0.063 +1.60	-0.031 -0.79	1.000 25.40	0.563* 14.30	23.656 600.86	-0.030 -0.76	0.172 4.37	0.375 9.53

* 9/16"(0.562")/14mm width groove is required in sizes 22 - 24"/550 - 600mm in order to obtain the maximum allowable pipe end movement listed in Performance Data Charts. 1/2"/12mm width groove will give 1/2 the maximum allowable shown for 22 - 24"/550 - 600mm. For double groove tool bit information, contact Victaulic.

@ Always refer to the I-100 handbook for current grooving specifications.

Pipe Preparation

Groove Dimensions

"ES" ROLL/CUT GROOVE SPECIFICATIONS NOTES

For Complete Information Request Publication **25.02**

GROOVE DIMENSION NOTES:

Column 1: Nominal IPS Pipe Size

Nominal metric (ISO) pipe size.

Column 2: IPS Outside Diameter

Metric (ISO) outside diameter.

The outside diameter of roll grooved pipe shall not vary more than the tolerance listed. For IPS pipe, the maximum allowable tolerance from square cut ends is 0.030" for ¾ – 3½"/20 – 90 mm; 0.045" for 4 – 6"/100 – 150 mm; and 0.060" for sizes 203.2 mm and above measured from true square line. For (ISO) metric pipe, the maximum allowable tolerance from square cut ends is 0.76 mm for sizes 20 – 80 mm; 1.14 mm for sizes 100 – 150 mm; and 1.52 mm for sizes 200 mm and above, measured from the true square line.

Column 3: Gasket Seat

The pipe surface shall be free from indentations, roll marks, and projections from the end of the pipe to the groove, to provide a leak-tight seal for the gasket. All loose paint, scale, dirt, chips, grease and rust must be removed. Square cut pipe must be used with FlushSeal and EndSeal gaskets. Gasket seat "A" is measured from the end of the pipe.

Column 4: Groove Width

bottom of groove to be free of loose dirt, chips, rust and scale that may interfere with proper coupling assembly. Corners at bottom of roll groove must be radiused. For IPS pipe, 0.04R on 1½ – 12"/40 – 300 mm. For (ISO) metric pipe, 1.2R mm on 20 – 300 mm.

Column 5: Groove Outside Diameter

The groove must be uniform depth for the entire pipe circumference. Groove must be maintained within the "C" diameter tolerance listed.

Column 6: Groove Depth

For reference only. Groove must conform to the groove diameter "C" listed.

Column 7: Minimum Allowable Wall Thickness

This is the minimum wall thickness which may be grooved.

Column 8: Maximum Allowable End Flare Diameter

Measured at the most extreme pipe end diameter square cut or beveled.

"ES" CUT GROOVE SPECIFICATIONS @

1		2		3		4		5		6	7
Size		Pipe Outside Dia. Inches/mm		Dimensions – Inches/mm							
Nominal Size Inches/mm	Actual Outside Diameter Inches/mm	Tolerance		Gasket Seat A		Grv. Width B		Groove Diameter C		D Groove Depth ref.	T Minimum Allow. Wall Thick.
		+	-	Basic	Tol.	Basic	Tol. +0.010 +0.25	Basic	Tol. +0.000 +0.00		
2 50	2.375 60.3	+0.024 +0.61	-0.024 -0.61	0.562 14.27	±0.010 ±0.25	0.255 6.48	-0.005 -0.13	2.250 57.15	-0.015 -0.38	0.063 1.60	0.154 3.91
2½ 65	2.875 73.0	+0.029 +0.74	-0.029 -0.74	0.562 14.27	±0.010 ±0.25	0.255 6.48	-0.005 -0.13	2.720 69.09	-0.018 -0.46	0.078 1.98	0.188 4.78
3 80	3.500 88.9	+0.035 +0.89	-0.031 -0.79	0.562 14.27	±0.010 ±0.25	0.255 6.48	-0.005 -0.13	3.344 84.94	-0.018 -0.46	0.078 1.98	0.188 4.78
4 100	4.500 114.3	+0.045 +1.14	-0.031 -0.79	0.605 15.37	±0.015 ±0.38	0.305 7.75	-0.005 -0.13	4.334 110.08	-0.020 -0.51	0.083 2.11	0.203 5.16
6 150	6.625 168.3	+0.063 +1.60	-0.031 -0.79	0.605 15.37	±0.015 ±0.38	0.305 7.75	-0.005 -0.13	6.455 163.96	-0.022 0.56	0.085 2.16	0.219 5.56
8 200	8.625 219.1	+0.063 +1.60	-0.031 -0.79	0.714 18.14	±0.015 ±0.38	0.400 10.16	-0.010 -0.25	8.441 214.40	-0.025 -0.64	0.092 2.34	0.238 6.05
10 250	10.750 273.0	+0.063 +1.60	-0.031 -0.79	0.714 18.14	±0.015 ±0.38	0.400 10.16	-0.010 -0.25	10.562 268.28	-0.027 -0.69	0.094 2.39	0.250 6.35
12 300	12.750 323.9	+0.063 +1.60	-0.031 -0.79	0.714 18.14	±0.015 ±0.38	0.400 10.16	-0.010 -0.25	12.531 318.29	-0.030 -0.76	0.109 2.77	0.279 7.09

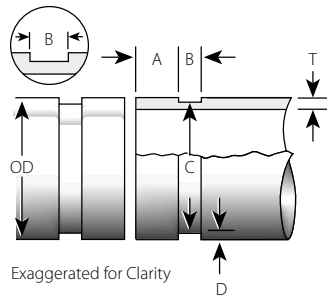

@ Always refer to the I-100 handbook for current grooving specifications.

IMPORTANT NOTES:

Coatings applied to the interior surfaces, including bolt pad mating surfaces, of our grooved and bolted plain end couplings should not exceed 0.010"/0.25 mm. Also, the coating thickness applied to the gasket seating surface and within the groove on the pipe exterior should not exceed 0.010"/0.25 mm.

"ES" ROLL GROOVE SPECIFICATIONS @

1		2		3		4		5		6	7	8
Size		Pipe Outside Dia. Inches/mm		Dimensions – Inches/mm								
Nominal Size Inches/mm	Actual Out. Dia. Inches/mm	Tolerance		Gasket Seat A		Grv. Width B		Groove Dia. C		D Groove Depth ref.	T Minimum Allow. Wall Thick.	Maximum Allow. Flare Diameter
		+	-	Basic	Tol.	Basic	Tol. +0.000 +0.00	Basic	Tol. +0.000 +0.00			
2 50	2.375 60.3	+0.024 +0.61	-0.024 -0.61	0.572 14.43	-0.020 ±0.51	0.250 6.35	+0.015 +0.38	2.250 57.15	-0.015 -0.38	0.063 1.60	0.065 1.65	2.48 63.0
2½ 65	2.875 73.0	+0.029 +0.74	-0.029 -0.74	0.572 14.53	-0.020 ±0.51	0.250 6.35	+0.015 +0.38	2.720 69.09	-0.018 -0.46	0.078 1.98	0.083 2.11	2.98 75.7
3 80	3.500 88.9	+0.035 +0.89	-0.031 -0.79	0.572 14.53	-0.020 ±0.51	0.250 6.35	+0.015 +0.38	3.344 84.94	-0.018 -0.46	0.083 2.11	0.083 2.11	3.60 91.4
4 100	4.500 114.3	+0.045 +1.14	-0.031 -0.79	0.610 15.49	-0.020 ±0.51	0.300 7.62	+0.020 +0.51	4.334 110.08	-0.020 -0.51	0.083 2.11	0.083 2.11	4.60 116.8
6 150	6.625 168.3	+0.063 +1.60	-0.031 -0.79	0.610 15.49	-0.020 ±0.51	0.300 7.62	+0.020 +0.51	6.455 163.96	-0.022 0.56	0.085 2.16	0.109 2.77	6.73 170.9
8 200	8.625 219.1	+0.063 +1.60	-0.031 -0.79	0.719 18.26	-0.020 ±0.51	0.390 9.91	+0.020 +0.51	8.441 214.40	-0.025 -0.64	0.092 2.34	0.109 2.77	8.80 223.5
10 250	10.750 273.0	+0.063 +1.60	-0.031 -0.79	0.719 18.26	-0.020 ±0.51	0.390 9.91	+0.020 +0.51	10.562 268.28	-0.027 -0.69	0.094 2.39	0.134 3.40	10.92 277.4
12 300	12.750 323.9	+0.063 +1.60	-0.031 -0.79	0.719 18.26	-0.020 ±0.51	0.390 9.91	+0.020 +0.51	12.531 318.29	-0.030 -0.76	0.109 2.77	0.156 3.96	12.92 328.2

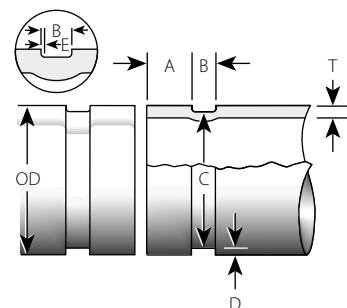

@ Always refer to the I-100 handbook for current grooving specifications.

IMPORTANT NOTES:

Coatings applied to the interior surfaces, including bolt pad mating surfaces, of our grooved and bolted plain end couplings should not exceed 0.010"/0.25 mm. Also, the coating thickness applied to the gasket seating surface and within the groove on the pipe exterior should not exceed 0.010"/0.25 mm.

Pipe Preparation

Groove Dimensions

FLEXIBLE RADIUS CUT GROOVE SPECIFICATION NOTES

For Complete Information
Request Publication **25.05**

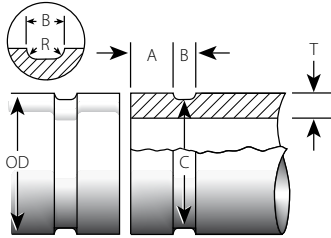

FLEXIBLE RADIUS CUT GROOVE SPECIFICATIONS – DUCTILE IRON PIPE@

1 Nominal Size Inches mm	2 Pipe Outside Diameter O.D. Inches mm			5 – Dimensions – Inches/mm						7 T Min. Allow. Wall Thick.	
				A Gasket Seat +0.000 -0.020	B Groove Width +0.031 -0.016	C Grv. Dia.		R Radius	T		
	Basic	+	-			Basic	Tol. +0.000		Cast Iron	Ductile Iron	
3 80	3.96 100.6	+0.045 +1.14	-0.045 -1.14	0.750 19.05	0.375 9.53	3.723 94.56	-0.020 -0.51	0.120 3.05	0.32 8.1	0.31 7.9	
4 100	4.80 121.9	+0.045 +1.14	-0.045 -1.14	0.750 19.05	0.375 9.53	4.563 115.90	-0.020 -0.51	0.120 3.05	0.35 8.9	0.32 8.1	
6 150	6.90 175.3	+0.060 +1.52	-0.060 -1.52	0.750 19.05	0.375 9.53	6.656 169.06	-0.020 -0.51	0.120 3.05	0.38 9.7	0.34 8.6	
8 200	9.05 229.9	+0.060 +1.52	-0.060 -1.52	0.875 22.23	0.500 12.70	8.781 223.04	-0.025 -0.64	0.145 3.68	0.41 10.4	0.36 9.1	
10 250	11.10 281.9	+0.060 +1.52	-0.060 -1.52	0.938 23.83	0.500 12.70	10.813 274.65	-0.025 -0.64	0.145 3.68	0.44 11.2	0.38 9.7	
12 300	13.20 335.3	+0.060 +1.52	-0.060 -1.52	0.938 23.83	0.500 12.70	12.906 327.81	-0.030 -0.76	0.145 3.68	0.48 12.2	0.40 10.2	
14 350	15.30 388.6	+0.050 +1.27	-0.080 -2.03	0.938 23.83	0.625 15.88	14.969 380.21	-0.030 -0.76	0.165 4.19	0.55 14.0	0.42 10.7	
16 400	17.40 442.0	+0.050 +1.27	-0.080 -2.03	1.188 30.18	0.625 15.88	17.063 433.40	-0.030 -0.76	0.165 4.19	0.58 14.7	0.43 10.9	
18 450	19.50 495.3	+0.050 +1.27	-0.080 -2.03	1.188 30.18	0.625 15.88	19.125 485.78	-0.030 -0.76	0.185 4.70	0.63 16.0	0.44 11.2	
20 500	21.60 548.6	+0.050 +1.27	-0.080 -2.03	1.188 30.18	0.625 15.88	21.219 538.96	-0.030 -0.76	0.185 4.70	0.67 17.0	0.45 11.4	
24 600	25.80 655.3	+0.050 +1.27	-0.080 -2.03	1.188 30.18	0.625 15.88	25.406 645.31	-0.030 -0.76	0.185 4.70	0.73 18.5	0.47 11.9	
30 750	32.00 812.8	+0.080 +2.03	-0.060 -1.52	1.375 34.93	0.750 19.05	31.550 801.37	-0.035 -0.89	0.215 5.46	0.92 23.4	0.51 13.0	
36 900	38.30 972.8	+0.080 +2.03	-0.060 -1.52	1.375 34.93	0.750 19.05	37.850 961.39	-0.035 -0.89	0.215 5.46	1.02 25.9	0.58 14.7	

@ Always refer to the I-300 handbook for current grooving specifications.

IMPORTANT NOTES:

Victaulic groove specifications for cast pipe (gray and ductile) conform to requirements of ANSI/AWWA standard C-606 and CSA B242.

For cast pipe, the groove is cut with a radius ("R" dimension) at the corners of the groove base to reduce stress concentration. Grooving dimensions are the same for any one pipe O.D. regardless of pipe class and pressure.

Standard preparation is with a rigid radius groove. Flexible radius groove dimensions may be used to provide expansion/contraction or angular movement allowance at the joint.

GROOVE DIMENSION NOTES: SEE PG. 17-24

Pipe Preparation

Groove Dimensions

RIGID RADIUS CUT GROOVE SPECIFICATION NOTES

For Complete Information
Request Publication 25.05

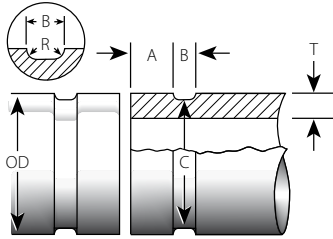

RIGID RADIUS CUT GROOVE SPECIFICATIONS – DUCTILE IRON PIPE@

1 Nominal Size Inches mm	2 Pipe Outside Diameter O.D. Inches mm			5 Dimensions – Inches/mm					7 T Min. Allow. Wall Thick.	
				A Gasket Seat +0.000 -0.020	B Groove Width +0.031 -0.016	C Grv. Diameter		R Radius	Cast Iron	Ductile Iron
	Basic	Tol. +0.000	R Radius			Cast Iron	Ductile Iron			
3 80	3.96 100.6	+0.045 +1.14	-0.045 -1.14	0.840 21.34	0.375 9.5	3.723 94.56	-0.020 -0.51	0.120 3.05	0.32 8.1	0.31 7.9
4 100	4.80 121.9	+0.045 +1.14	-0.045 -1.14	0.840 21.34	0.375 9.53	4.563 115.90	-0.020 -0.51	0.120 3.05	0.35 8.9	0.32 8.1
6 150	6.90 175.3	+0.060 +1.52	-0.060 -1.52	0.840 21.34	0.375 9.53	6.656 169.06	-0.020 -0.51	0.120 3.05	0.38 9.7	0.34 8.6
8 200	9.05 229.9	+0.060 +1.52	-0.060 -1.52	0.950 24.13	0.500 12.70	8.781 223.04	-0.025 -0.64	0.145 3.68	0.41 10.4	0.36 9.1
10 250	11.10 281.9	+0.060 +1.52	-0.060 -1.52	1.015 25.78	0.500 12.70	10.813 274.65	-0.025 -0.64	0.145 3.68	0.44 11.2	0.38 9.7
12 300	13.20 335.3	+0.060 +1.52	-0.060 -1.52	1.015 25.78	0.500 12.70	12.906 327.81	-0.030 -0.76	0.145 3.68	0.48 12.2	0.40 10.2
14 350	15.30 388.6	+0.050 +1.27	-0.080 -2.03	1.015 25.78	0.625 15.88	14.969 380.21	-0.030 -0.76	0.165 4.19	0.55 14.0	0.42 10.7
16 400	17.40 442.0	+0.050 +1.27	-0.080 -2.03	1.340 34.04	0.625 15.88	17.063 433.40	-0.030 -0.76	0.165 4.19	0.58 14.7	0.43 10.9
18 450	19.50 495.3	+0.050 +1.27	-0.080 -2.03	1.340 34.04	0.625 15.88	19.125 485.78	-0.030 -0.76	0.185 4.70	0.63 16.0	0.44 11.2
20 500	21.60 548.6	+0.050 +1.27	-0.080 -2.03	1.340 34.04	0.625 15.88	21.219 538.96	-0.030 -0.76	0.185 4.70	0.67 17.0	0.45 11.4
24 600	25.80 655.3	+0.050 +1.27	-0.080 -2.03	1.340 34.04	0.625 15.88	25.406 645.31	-0.030 -0.76	0.185 4.70	0.73 18.5	0.47 11.9
30 750	32.00 812.8	+0.080 +2.03	-0.060 -1.52	1.625 41.28	0.750 19.05	31.550 801.37	-0.035 -0.89	0.215 5.46	0.92 23.4	0.51 13.0
36 900	38.30 972.8	+0.080 +2.03	-0.060 -1.52	1.625 41.28	0.750 19.05	37.850 961.39	-0.035 -0.89	0.215 5.46	1.02 25.9	0.58 14.7

@ Always refer to the I-300 handbook for current grooving specifications.

IMPORTANT NOTES:

Victaulic groove specifications for cast pipe (gray and ductile) conform to requirements of ANSI/AWWA standard C-606 and CSA B242.

For cast pipe, the groove is cut with a radius ("R" dimension) at the corners of the groove base to reduce stress concentration. Grooving dimensions are the same for any one pipe O.D. regardless of pipe class and pressure.

Standard preparation is with a Rigid radius groove. Flexible radius groove dimensions may be used to provide expansion/contraction or angular movement allowance at the joint.

GROOVE DIMENSION NOTES:

Column 1: Nominal AWWA Pipe Size

Column 2 : AWWA Pipe Size Outside Diameter

The average pipe outside diameter must not vary from the specifications listed in the tables on the following pages. Maximum allowable pipe ovality should not vary by more than 1%. Greater variations between the major and minor diameters will result in difficult coupling assembly. For ductile iron pipe, the maximum allowable tolerance from square-cut pipe ends is 0.030"/0.8 mm for 3"/80 mm size; 0.045"/1.1 mm for 4–6"/100–150 mm sizes; and 0.060"/1.5 mm for sizes 8"/200 mm and larger sizes. This is measured from the true square line.

Column 3 : Gasket Seat "A" Dimension

The "A" dimension, or the distance from the pipe end to the groove, identifies the gasket seating area. This area must be smooth and free from indentations, projections, deep pits, and swells from the pipe end to the groove to provide a leak-tight seal for the gasket. All rust, loose scale, oil, grease, dirt, and cutting particles must be removed. Peened surfaces may require rework to provide a leak-tight seal for the gasket (refer to ANSI/AWWA C-606 or CSA B242).

Column 4: Groove Width "B" Dimension

The "B" dimension, or groove width, controls expansion and angular deflection by the distance it is located from the pipe and its width in relation to the housings' "key" width.

Column 5: Groove Diameter "C" Dimension

The "C" dimension is the proper diameter at the base of the groove. This dimension must be within the diameter's tolerance and concentric with the O.D. for proper coupling fit. The groove must be of uniform depth for the entire pipe circumference.

Column 6: Radius "R" Dimension

The "R" dimension is the radius necessary at the bottom of the groove to eliminate a point of stress concentration for cast pipe (gray and ductile).

Column 7: Minimum Allowable Wall Thickness "T" Dimension

The "T" dimension is the minimum wall thickness that can be cut grooved. The tolerances must conform to Class 53 ANSI/AWWA C151/A21.51. Class 53 ductile iron pipe in sizes 18–36"/450–900 mm can be cut grooved. Contact Victaulic for details.

Product Index

Style No.	Product Description	Page No.	Publ. No.
COUPLINGS, PGS. 1-5 - 1-18			
Style 107	Quick Vic Rigid Coupling	1-5	06.19
Style 07	Zero-Flex Rigid Coupling	1-6	06.02
Style 177	Quick Vic Flexible Coupling	1-7	06.02
Style HP-70	Rigid Coupling	1-17	06.12
Style 72	Outlet Coupling	1-15	06.10
Style 75	Flexible Coupling	1-9	06.05
Style 77	Standard Flexible Coupling	1-8	06.04
Style 78	Snap-Joint Coupling	1-14	06.09
Style 741	Vic-Flange Adapter ANSI Class 150	1-11	06.06
Style 743	Vic-Flange Adapter ANSI Class 300	1-12	06.06
Style 750	Reducing Coupling	1-13	06.08
Style 770	Large Diameter Pipe Coupling	1-10	06.03
Style 791	Vic-Boltless Coupling	1-16	06.11
Style 792	Vic-Boltless Assembly Tool	1-16	06.11
Style 808	High Pressure Coupling	1-18	06.11
ENDSEAL COUPLING AND FITTINGS, PGS. 1-19 -1-20			
Style HP-70ES	EndSeal Coupling for Plastic Coated Pipe	1-19	06.13
No. 22-ES	EndSeal Header Tee for Plastic Coated Pipe	1-20	07.03
No. 35-ES	EndSeal Cross for Plastic Coated Pipe	1-20	07.03
No. 62-ES	EndSeal 90° Elbow for Plastic Coated Pipel	1-20	07.03
No. 63-ES	EndSeal 45° Elbow for Plastic Coated Pipe	1-20	07.03
No. 64-ES	EndSeal Tee for Plastic Coated Pipe	1-20	07.03
FITTINGS, PGS. 2-1 - 2-16			
Elbows			
No. 10	90° Elbow	2-3	07.01
No. 10-DR	Drain Elbow	2-4	10.05
No. 11	45° Elbow	2-3	07.01
No. 12	22½° Elbow	2-3	07.01
No. 13	11¼° Elbow	2-3	07.01
No. 18	90° Adapter Elbow	2-5	07.01
No. 19	45° Adapter Elbow	2-5	07.01
Tees, Crosses, Wyes, and Laterals			
No. 20	Tee	2-6	07.01
No. 21	Bullhead Tee	2-8	07.01
No. 25	Reducing Tee	2-7,8	07.01
No. 27	Standpipe Tee	2-8	07.01
No. 29T	Reducing Tee with Threaded Branch	2-7,8	07.01
No. 29M	Tee with Threaded Branch	2-6	07.01
No. 30	45° Lateral	2-9	07.01
No. 30-R	45° Reducing Lateral	2-9	07.01
No. 32	Tee Wye	2-10	07.01
No. 32-R	Reducing Tee Wye	2-10	07.01
No. 33	True Wye	2-6	07.01
No. 35	Cross	2-6	07.01
Adapters, Nipples, Caps, and Plugs			
No. 40	Adapter Nipple – Grv. x Thd.	2-11	07.01
No. 41	Flange Adapter Nipple – ANSI Class 125	2-12	07.01
No. 42	Adapter Nipple – Grv. x Bev.	2-11	07.01

Style No.	Product Description	Page No.	Publ. No.
No. 43	Adapter Nipple – Grv. x Grv.	2-11	07.01
No. 45R	Raised Face Flange Adapter Nipple – ANSI Class 150	2-12	07.01
No. 45F	Flat Faced Adapter Nipple	2-12	07.01
No. 46R	Raised face Flange Adapter Nipple – ANSI Class 300	2-12	07.01
No. 48	Hose Nipple	2-14	07.01
Reducers			
No. 50	Concentric Reducer	2-15	07.01
No. 51	Eccentric Reducer	2-15	07.01
No. 52	Small Threaded Reducer	2-16	07.01
FITTINGS, PGS. 2-1 - 2-16			
No. 53	Swaged Nipple – Grv. x Grv.	2-13	07.01
No. 54	Swaged Nipple – Grv. x Thd.	2-13	07.01
No. 55	Swaged Nipple – Thd. x Grv.	2-13	07.01
No. 60	Cap	2-11	07.01
No. 61	Bull Plug	2-8	07.01
No. 80	Female Threaded Adapter	2-14	07.01
No. 100	90° 1½ D Long Radius Elbow	2-3	07.01
No. 100-3D	90° 1½ D Long Radius Elbow	2-4	07.01
No. 110	45° 3D Long Radius Elbow	2-3	07.01
No. 110-3D	45° 3D Long Radius Elbow	2-4	07.01
No. R-10F	Reducing Base Elbow – Grv. x Flange	2-4	07.01
No. R-10G	Reducing Base Elbow – Grv. x Grv.	2-4	07.01
VALVES, PGS. 3-1 - 3-20			
TA Series 73M	TA CMI Pressure Differential Meter	3-20	08.16
Series 78U	Union Port Fitting	3-16	08.16
Series 78Y	Strainer/Ball Valve Combination	3-17	08.16
Series 377	Vic-Plug Balancing Valve	3-10	08.12
Series 700	Butterfly Valve	3-6	08.05
Series 712	Swinger Swing Check Valve – 300 psi/2065 kPa	3-9	08.11
Series 713	Swinger Swing Check Valve – 1000 psi/6900 kPa	3-9	08.11
Series 716	Vic-Check Valve	3-7	08.08
Series 721	Vic Ball Valve	3-11	08.14
Series 722	Brass Body Ball Valve	3-11	08.15
Series 726	Vic-Ball Valve	3-13	08.23
TA Series 736	TA Link Differential Pressure Sensor	3-19	08.16
TA Series 737	TA Hand Held Circuit Balancing Instrument	3-19	08.16
TA Series 738	TA Portable Differential Pressure Meter	3-19	08.16
Series 779	Venturi Check Valve	3-8	08.10
TA Series 786	Solder End	3-15	08.16
TA Series 786-DK	TA Drain Kit	3-19	08.16
TA Series 787	TA NPT (Female) Threaded End Balancing Valve	3-16	08.16
TA Series 788	TA Flanged End Balancing Valve	3-15	08.16
TA Series 793	Threaded End	3-17	08.29
TA Series 794	Flanged End	3-18	08.29
TA Series 789	TA Groove End Balancing Valve	3-15	08.16
—	TA Select III Computer Program	3-20	08.16
—	Triple Service Valve Assembly	3-5	08.09
Vic-300 MS	Vic-300 MasterSeal Butterfly Valve	3-3	08.20

Product Index

Style No.	Product Description	Page No.	Publ. No.
ACCESSORIES, PGS. 4-1 - 4-10			
No. 47	Dielectric Waterway Fitting	4-9	09.07
Series 730	Vic-Strainer – Tee Type	4-5	09.02
Series 731-I	Suction Diffuser with ANSI Class 150 Flange	4-3	09.14
Series 732	Vic-Strainer – Wye Type	4-6	09.03
Style 150	Mover Expansion Joint	4-7	09.04
Style 155	Standard Expansion Joint	4-8	09.05
ADVANCED GROOVE SYSTEM (AGS), PGS. 5-1 - 5-17			
Style W07	Rigid Coupling	5-3	20.02
Style W77	Flexible Coupling	5-3	20.03
Style W89	Rigid Coupling	5-4	20.15
Style W741	Vic-Flange® Adaptor	5-5	20.04
Style W155	Expansion Joint	5-4	20.12
No. W10	90° Elbow	5-6	20.05
No. W11	45° Elbow	5-6	20.05
No. W12	22½° Elbow	5-6	20.05
No. W13	11¼° Elbow	5-6	20.05
No. W20	Tee	5-6	20.05
No. W25	Reducing Tee	5-7	20.05
No. W30	45° Lateral	5-8	20.05
No. W30-R	45° Reducing Lateral	5-8	20.05
No. W33	True Wye	5-6	20.05
No. W35	Cross	5-6	20.05
No. W42	Adapter Nipple – AGS Grv. x Bev.	5-9	20.05
No. W43	Adapter Nipple – AGS Grv. x AGS Grv.	5-9	20.05
No. W45-R	Flange Adapter Nipple – ANSI Class 150	5-9	20.05
No. W49	Adapter Nipple – AGS Grv. x Non AGS Grv.	5-9	20.05
No. W50	Concentric Reducer	5-10	20.05
No. W51	Eccentric Reducer	5-10	20.05
No. W60	Cap	5-9	20.05
No. W100	90° 1 ½ D Long Radius Elbow	5-6	20.05
No. W110	45° 1 ½ D Long Radius Elbow	5-6	20.05
	Vic-300 Masterseal AGS Butterfly Valve	5-12	20.06
	Triple Service Valve Assembly	5-14	20.18
Series W715	Dual Disc Vic-Check Valve	5-11	20.08
Series W730	Vic-Strainer – Tee Type	5-16	20.11
Style W732	Wye Type Vic-Strainer	5-17	20.19
Series W731-I	Suction Diffuser with ANSI Class 150 Flange	5-15	20.10
HOLE CUT PIPING SYSTEM, PGS. 6-1 - 6-6			
Style 920	Mechanical-T Bolted Branch Outlet	6-2	11.02
Style 920N	Mechanical-T Bolted Branch Outlet	6-2	11.02
Style 923	Vic-Let Strapless Outlet	6-5	11.05
Style 924	Vic-O-Well Strapless Thermometer Outlet	6-6	11.06
PLAIN END PIPING SYSTEM FOR STEEL PIPE, PGS. 7-1 - 7-8			
Style 99	Roust-A-Bout Coupling	7-3	14.02
No. 20P	Tee	7-5	14.04

Style No.	Product Description	Page No.	Publ. No.
No. 25P	Reducing Tee	7-6	14.04
No. 30P	45° Lateral	7-6	14.04
No. 33P	True Wye	7-5	14.04
No. 35P	Cross	7-5	14.04
No. 40P	Adapter Nipple – Plain End x Thd.	7-8	14.04
No. 42P	Adapter Nipple – Plain End x Bev.	7-8	14.04
No. 43P	Adapter Nipple – Plain End x Grv.	7-8	14.04
No. 53P	Swaged Nipple	7-7	14.04
No. 61P	Bull Plug	7-5	14.04
GROOVED SYSTEM FOR STAINLESS STEEL PIPE, PGS. 8-1 - 8-16			
Style 77S	Flexible Coupling	8-5	17.03
Style 89	Rigid Coupling	8-4	17.24
Style 441	Vic-Flange Adapter ANSI Class 150	8-7	17.27
Style 475	Flexible Coupling	8-6	17.12
Style 489	Rigid Coupling	8-3	17.25
No. 410 SS	90° Elbow	8-8	17.04
No. 411 SS	45° Elbow	8-8	17.04
No. 420 SS	Tee	8-8	17.04
No. 425 SS	Reducing Tee	8-9	17.04
No. 450 SS	Concentric Reducer	8-9	17.04
No. 460 SS	Cap	8-8	17.04
Series 712S	Swinger Check Valve	8-12	17.08
Series 726S	Vic-Ball Valve	8-13	17.22
Series 763	Butterfly Valve	8-10	17.23
PRESSFIT SYSTEM FOR STAINLESS STEEL PIPE, PGS. 9-1 - 9-12			
PRESSFIT SYSTEM 304			
Series 589	Ball Valve	9-11	18.02
Style 547	Grooved End Union	9-9	18.02
Style 561	Weld Adapter	9-8	18.02
Style 565	Van Stone Flange Adapter	9-9	18.02
Style 582	Reducer Insert	9-10	18.02
Style 584	Threaded Union	9-8	18.02
Style 586	90° Short Tangent Elbow	9-5	18.02
Style 587	Transition Nipple	9-10	18.02
Style 588	Tee with Threaded Branch	9-6	18.02
Style 590	90° Elbow	9-5	18.02
Style 591	45° Elbow	9-5	18.02
Style 592	Tee	9-6	18.02
Style 593	Tee with Reducing Branch	9-7	18.02
Style 594	Concentric Reducer	9-10	18.02
Style 595	Flange Adapter	9-9	18.02

Product Index

Style No.	Product Description	Page No.	Publ. No.
Style 596	Male Adapter	9-7	18.02
Style 597	Standard Coupling	9-4	18.02
Style 599	Female Threaded Adapter	9-8	18.02
PRESSFIT SYSTEM FOR STAINLESS STEEL PIPE, PGS. 9-1 - 9-12			
PRESSFIT SYSTEM 316			
Series 569	Ball Valve	9-12	18.01
Style 507	Standard Coupling	9-4	18.01
Style 508	Slip Coupling	9-4	18.01
Style 548	Grooved End Union	9-9	18.01
Style 566	Lap Joint Flange Adapter	9-9	18.01
Style 568	90° Short Tangent Elbow	9-5	18.01
Style 570	90° Elbow	9-5	18.01
Style 571	45° Elbow	9-5	18.01
Style 572	Tee	9-6	18.01
Style 573	Tee with Reducing Branch	9-7	18.01
Style 574	Concentric Reducer	9-10	18.01
Style 575	Flange Adapter	9-9	18.01
Style 576	Male Adapter	9-7	18.01
Style 577	Transition Nipple	9-10	18.01
Style 578	Tee with Threaded Branch	9-6	18.01
Style 579	Female Threaded Adapter	9-8	18.01
Style 583	Reducer Insert	9-10	18.01
Style 585	Threaded Union	9-8	18.01
PLAIN END PIPING SYSTEM FOR HDPE PIPE, PGS. 10-1 - 10-4			
Style 994	Vic-Flange Adapter ANSI Class 150	10-4	19.04
Style 995	Coupling	10-2	19.02
Style 997	Transition Coupling – HDPE to Steel	10-3	19.03
GROOVED COPPER PIPING SYSTEM, PGS. 11-1 - 11-10			
Style 606	Coupling	11-4	22.02
Style 607	QuickVic Rigid Coupling	11-3	22.13
Style 622	Mechanical-T Bolted Branch Outlet	11-5	22.12
Style 641	Vic-Flange Adapter	11-4	22.03
Series 608	Butterfly Valve	11-9	22.05
No. 610	90° Elbow	11-6	22.04
No. 611	45° Elbow	11-6	22.04
No. 620	Tee	11-6	22.04
No. 625	Reducing Tee – Grv. x Grv. x Grv.	11-8	22.04
No. 626	Reducing Tee – Grv. x Grv. x Cup	11-8	22.04
No. 650	Concentric Reducer – Grv. x Grv.	11-7	22.04
No. 652	Concentric Reducer – Grv. x Cup	11-7	22.04
No. 660	Cap	11-6	22.04
GROOVED AWWA DUCTILE IRON PIPE, PGS. 13-1 - 13-18			
Style 31	Coupling	13-3	23.02
Style 307	Transition Coupling – AWWA to IPS	13-5	23.03
Style 341	Vic-Flange Adapter	13-4	23.04
No. 10-C	90° Elbow	13-7	23.05
No. 10-CB	Base Elbow	13-13	23.05
No. 10-CF	90° Flare	13-14	23.05
No. 10-CR	90° Reducing Elbow	13-11	23.05

Style No.	Product Description	Page No.	Publ. No.
No. 10-CS	90° Side Outlet	13-14	23.05
No. 11-C	45° Elbow	13-7	23.05
No. 12-C	22½° Elbow	13-7	23.05
No. 13-C	11¼° Elbow	13-7	23.05
No. 20-C	Tee	13-8	23.05
No. 20-CB	Base Tee	13-13	23.05
No. 20-CS	Tee Side Outlet	13-14	23.05
No. 21-C	Bullhead Tee	13-8	23.05
No. 25-C	Reducing Tee	13-9	23.05
No. 25-CB	Reducing Base Tee	13-13	23.05
No. 30-C	45° Lateral	13-8	23.05
No. 30-CR	45° Reducing Lateral	13-9	23.05
No. 33-C	True Wye	13-8	23.05
No. 35-C	Cross	13-8	23.05
No. 35-CR	Reducing Cross	13-9	23.05
No. 43-CF	Straight Flare	13-14	23.05
No. 50-C	Concentric Reducer	13-11	23.05
No. 51-C	Eccentric Reducer	13-11	23.05
No. 60-C	Cap	13-8	23.05
No. 100-C	90° Long Radius Elbow	13-7	23.05
No. 100-CB	Base Elbow	13-13	23.05
No. 100-CF	90° Long Radius Flare	13-14	23.05
No. 100-CR	90° Long Radius Reducing Elbow	13-11	23.05
Series 317	Check Valve	13-16	23.09
Series 365	Vic-Plug Valve with AWWA Standard Ends	13-15	23.06
PIPE PREPARATION TOOLS, PGS. 17-1 - 17-24			
ROLL GROOVING TOOLS			
VE12	Groove In-Place – Steel	17-3	24.01
VE26	Groove In-Place	17-3	24.01
VE46	Groove In-Place	17-3	24.01
VE106	Groove-N-Go	17-4	24.01
VE226	Portable Roll Groover	17-3	24.01
VE270FSD	Field Roll Groover	17-4	24.01
VE272SFS	Field Roll Groover	17-4	24.01
VE268	Shop Roll Groover	17-5	24.01
VE414MC	Vic-Easy Shop Roll Groover	17-5	24.01
VE416FSD	Field Roll Groover	17-4	24.01
VE450FSD	Shop Roll Groover	17-5	24.01
VE436MC	Production Roll Groover	17-5	24.01
CUT GROOVING TOOLS			
VG46	Vic Groover	17-9	24.01
VG28GD	Adjustable Cut Groover	17-8	24.01
VG824	Adjustable Cut Groover	17-8	24.01
VG828	AGS Cut Grooving Tool	17-8	24.01
VG412	Orbital Tool	17-9	24.01
VPG26	PVC Plastic Groover	17-9	24.01
VPG824	PVC Plastic Groover	17-9	24.01

Style No.	Product Description	Page No.	Publ. No.
PRESSFIT TOOLS			
PFT505	Pressfit Tool	17-11	24.01
PFT509	Pressfit Tool	17-11	24.01
PIPE CUTTING TOOLS			
HCT908	Hole Cutting Tool	17-11	24.01
VHCT900	Vic Hole Cutting Tool	17-11	24.01
Vic-Tap II	Hole Cutting Tool	17-11	24.01
VCT1	Cut-Off Tool – Manual	17-12	24.01
VCT2	Cut-Off Tool – Manual	17-12	24.01
ACCESSORIES			
VPD752	Power Drive	17-13	24.01
Power Mule	Power Drive	17-13	24.01
VAPS112	Small Pipe Stand	17-13	24.01
VAPS224	Heavy Duty Pipe Stand	17-14	24.01
Pipe Tape	Diameter Tape	17-14	24.01

We warrant all products to be free from defects in materials and workmanship under normal conditions of use and service. Our obligation under this warranty is limited to repairing or replacing at our option at our factory any product which shall within one year after delivery to original buyer be returned with transportation charges prepaid, and which our examination shall show to our satisfaction to have been defective.

THIS WARRANTY IS MADE EXPRESSLY IN LIEU OF ANY OTHER WARRANTIES, EXPRESS OR IMPLIED, INCLUDING ANY IMPLIED WARRANTY OF MERCHANTABILITY OR FITNESS FOR A PARTICULAR PURPOSE. THE BUYER'S SOLE AND EXCLUSIVE REMEDY SHALL BE FOR THE REPAIR OR REPLACEMENT OF DEFECTIVE PRODUCTS AS PROVIDED HEREIN. THE BUYER AGREES THAT NO OTHER REMEDY (INCLUDING, BUT NOT LIMITED TO, INCIDENTAL OR CONSEQUENTIAL DAMAGES FOR LOST PROFITS, LOST SALES, INJURY TO PERSON OR PROPERTY OR ANY OTHER INCIDENTAL OR CONSEQUENTIAL LOSS) SHALL BE AVAILABLE TO HIM.

Victaulic neither assumes nor authorizes any person to assume for it any other liability in connection with the sale of such products.

This warranty shall not apply to any product which has been subject to misuse, negligence or accident, which has been repaired or altered in any manner outside of Victaulic's factory or which has been used in a manner contrary to Victaulic's instructions or recommendations. Victaulic shall not be responsible for design errors due to inaccurate or incomplete information supplied by Buyer or its representatives. Items purchased by Victaulic and resold will have the original equipment manufacturer's warranty extended to Victaulic customers.

Effective August 4, 2008

All products shall be installed in accordance with current Victaulic installation/assembly instructions. Victaulic reserves the right to change product specifications, designs and standard equipment without notice and without incurring obligations.

Piping Software

The Victaulic software solutions group helps to increase piping project productivity by offering free software packages to aid you in developing and drawing Victaulic piping systems. In addition, Victaulic components can now be found in many of the major third party software drawing packages listed below:

THIRD PARTY SOFTWARE

Aveva (Cadcentre) PDMS
Bentley – AutoPlant
Bentley – PlantSpace
CEA Systems – Plant 4D
Coade – CADWorx Pipe
Hydratec – HydraCAD (Fire Protection)
Intergraph PDS

Find software online at www.victaulic.com/software

Demos of our software packages can be downloaded from our website or the complete software package can be ordered online in CD-ROM format. Visit our website to begin accessing our electronic services, or call 1-800-PICK-VIC.



Vic-Blocks – designed specifically for AutoCAD users, Vic-Blocks 3D is a dimensionally accurate, three-dimensional block library that was developed to assist with Victaulic piping system layouts. It includes block symbols representing the main product line, drawn at full size.

Vic-Blocks

Both Vic-Blocks 2D and Vic-Blocks 3D are compatible with the AutoCad two- and three-dimensional library system. AutoCad is available free, to assist in drawing Victaulic couplings, fittings and valves. Demonstration modules are available for viewing on our website.

Vic-Cells

Designed specifically for MicroStation users, Vic-Cells is a dimensionally accurate 2D compilation of cell libraries developed to assist with Victaulic piping system layouts.

Vic-PDS Piping Specs

Vic-PDS piping specs are a set of Integraph Plant Design System (PDS) piping specifications, allowing users to access and use Victaulic products in their PDS piping systems design.

Vic-PDMS Piping Catalog

Vic-PDMS Piping Catalogs is a set of Aveva (Cadcentre) plant design management system (PDMS) catalogs that allows users to access and use Victaulic products in their PDMS piping systems designs.

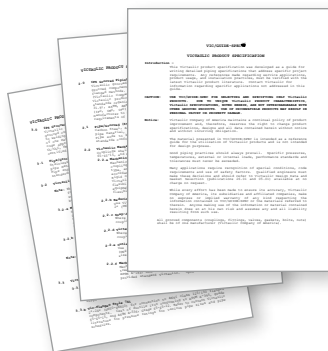

Vic-Guide Spec

Vic-Guide Spec provides typical specifications for most Victaulic products. The data can be directly cut and pasted into your specifications. Vic-Guide Spec is available in PDF or Word format.

*AutoCad is a registered trademark of Autodesk



World Class Service and Support

Piping. Systems. Solutions.



Value-added services

Construction Piping Services (CPS)

Our Construction Piping Services group can help you make effective and efficient use of Victaulic piping systems through its estimating, project management and drawing package expertise and services. In the US CPS can be reached at 1-610-559-3488 or by email at cps@victaulic.com. CPS offers the following:

VALUE ANALYSIS

Analyzing contract drawings provided by you, CPS will develop cost/pricing and cost comparison summaries of Victaulic systems versus welded, flanged, threaded and other mechanical pipe joining systems using current street prices for materials and recent labor times calculated from trade association standards.

PROJECT MANAGEMENT

CPS can provide quotes for preparation of detailed piping drawings for fabrication and erection, including pipe routing layout; sectional views and isometric drawings; and cut sheets and bills of material. A CPS project coordinator is assigned to begin tracking all the necessary documentation, including organizing the delivery of material according to your construction schedule.

FIELD SERVICE

Victaulic is the only mechanical piping systems manufacturer with 200+ factory-trained piping specialists worldwide to service your needs.

ENGINEERED PRODUCTS

Through our engineered products services, special attention is paid to projects that require special alloys, non-ferrous materials, special coatings or non-standard or special code applications. Call us for an evaluation.

Standing alongside every Victaulic product and mechanical piping system solution is a service and support team ready to assist you with your next project.

Our staff of experienced sales representatives, on-site training personnel and engineering professionals are a phone call away for help in facilitating the evaluation, planning and fulfillment of your piping system needs.

1-800-PICK-VIC

For immediate answers to your engineering or technical questions call 1-800-PICK-VIC (in the US only) or email engrserv@victaulic.com Monday through Thursday from 8:00 am to 7:30 pm EST/EDT and Friday from 8:00 am to 4:30 pm EST/EDT.

www.victaulic.com

For additional information about our products and services including a library of global projects to view, visit us on the web. From there you can easily access the most up-to-date product information organized by market and by product type.

Piping. Systems. Solutions.

www.victaulic.com

The Victaulic website is an information resource that can help you with your piping projects. Among the many resources available at the site:

- Fully searchable product and project databases
- Free product submittals
- Free product literature
- Piping software demos and modules
- Information on new product innovations
- Support services, and more...



VICTAULIC GLOBAL CONTACT INFORMATION

US & WORLD HEADQUARTERS

P.O. Box 31
Easton, PA 18044-0031 USA
4901 Kesslersville Road
Easton, PA 18040 USA
1-800-PICK-VIC
(+1-800-742-5842)
(within North America)
+1-610-559-3300
+1-610-250-8817 (fax)
pickvic@victaulic.com

CANADA

123 Newkirk Road
Richmond Hill, ON L4C 3G5
+1-905-884-7444
+1-905-884-9774 (fax)
viccanada@victaulic.com

www.victaulic.com

CENTRAL AND SOUTH AMERICA

P.O. Box 31
Easton, PA 18044-0031 USA
4901 Kesslersville Road
Easton, PA 18040 USA
+1-610-559-3300
+1-610-559-3608 (fax)
vical@victaulic.com

UNITED KINGDOM

Units B1 & B2, SG1 Industrial Park
Cockerell Close
Gunnels Wood Road
Stevenage
Hertfordshire, SG1 2NB (UK)
+44-(0)-1438-310-690
+44-(0)-1438-310-699 (fax)
0124-60219 (direct to Ireland
within the UK)
viceuro@victaulic.be

EUROPE

Prijkelstraat 36
9810 Nazareth, Belgium
+32-9-381-15-00
+32-9-380-44-38 (fax)
viceuro@victaulic.be

MIDDLE EAST

P.O. Box 17683
Unit XB 8
Jebel Ali Free Zone
Dubai
United Arab Emirates
+971-4-883-88-70
+971-4-883-88-60 (fax)

ASIA

Unit 06-10, Floor 3A
A Mansion 291 Fumin Road
Shanghai, China 200031
+86-21-6170-1222
+86-21-6170-1221 (fax)
vicap@victaulic.com

AUSTRALIA AND NEW ZEALAND

7 Chambers Road
Unit 1
Altona North, Victoria
Australia 3025
1-300-PIC-VIC
(+1-300-742-842)
(within Australia)
+61-39392-4000
+61-39399-9905 (fax)
vicaust@victaulic.com



WCAS-7RSH6G

UPDATED 6/2009
G-103 0798 REV N

VICTAULIC IS A REGISTERED TRADEMARK OF VICTAULIC COMPANY. © 2009 VICTAULIC COMPANY. ALL RIGHTS RESERVED.

